

CATÁLOGO GENERAL  
GENERAL CATALOGUE

2021

Next  
Ceramic  
Generation

rocersa®

**ROCERSA<sup>®</sup>**  
Catálogo General 2021

**Vol. 2**

# Sobre Nosotros

## About Us

Somos una empresa cerámica de referencia internacional con más de cuarenta años de experiencia con sede en Vila-real (Castellón). Rocersa fabrica y distribuye en todo el mundo, más de 6 millones de m<sup>2</sup> al año.

Nuestra pasión por la innovación nos ha permitido ser una de las primeras empresas en desarrollar **porcelánico de 20mm**, siendo un referente mundial.

La sostenibilidad, la tecnología, la sociedad y el ser humano, como claro protagonista de nuestro trabajo, son los valores sobre los que se constituye Rocersa desde su origen.

También invertimos recursos en conseguir fabricar productos cada vez con mayor contenido de material reciclado. Por eso Rocersa destaca entre sus competidores por fabricar productos que contienen entre el 44% y 62% de material reciclado. Trabajamos cada día para aumentar este porcentaje.

Para disminuir el consumo de energía, estamos inmersos en procesos de implantación de sistemas de intercambio de energía, recuperando el calor de los hornos y utilizándolos en los secaderos del producto crudo.

*Rocersa is a leading international tile manufacturer based in Vila-real (Castellón), with over 40 years of experience in the tile business. Each year, it manufactures and distributes over 6 million m<sup>2</sup> of tiles worldwide.*

*Thanks to the company's passion for innovation, it has become an international reference point as a pioneer in the development of 20mm-thick porcelain tiles.*

*Resources are also channelled into the development of tiles with an increasing recycled content. Rocersa stands out from its rivals for managing to develop products with a recycled content of between 44% and 62%, and it continues to work toward increasing these percentages.*

*To reduce energy consumption, it is in the midst of implementing energy exchange systems, using the heat from its kilns to operate driers used for unfired tiles.*

# Más de 6 millones m<sup>2</sup>/año

Over 6 million m<sup>2</sup>/per year

# Viker 7mm

Producto respetuoso  
con el medio ambiente  
Environmentally friendly product



Fácil manipulación  
Easy handling



Reducción del tiempo de obra  
Reduction of construction time



Fácil taladro, corte y manipulación  
Easy drilling, cutting and handling



Reducción del costes de transporte  
Reduction of transport costs



7mm

Viker da nombre a las colecciones de producto desarrolladas en porcelánico de tan sólo 7mm de espesor. Es la propuesta de Rocersa de un producto que facilita la colocación y permite un ahorro energético tanto en fabricación como por el menor consumo de materias primas. Su elegancia unida a su fino espesor le permite ser un producto ideal para proyectos de obra nueva o reformas. Es un producto más manejable, ligero y de fácil colocación. Con el uso de niveladores se consigue la colocación perfecta, sin resaltes ni salientes, gracias a su flexibilidad se adapta fácilmente a cualquier superficie.

Viker es color y textura, con gráficas exclusivas que representan las últimas tendencias en decoración. Todo esto combinado con su rápida y perfecta colocación lo convierte en el producto ideal para clientes exigentes.

*Viker is the name of the product collections developed in porcelain tiles only 7mm thick. It is Rocersa's proposal for a product that facilitates installation and allows energy savings both in manufacturing and in the lower consumption of raw materials. Its elegance combined with its thin thickness makes it an ideal product for new construction projects or refurbishments. It is a more manageable, lightweight and easy to lay product. With the use of levellers, a perfect installation is achieved, without protrusions or protrusions, thanks to its flexibility it adapts easily to any surface.*

*Viker is colour and texture, with exclusive graphics that represent the latest trends in decoration, all this combined with its quick and perfect installation makes it the ideal product for demanding customers.*

# OUTDOOR20

20mm

Nuestro trabajo está estrechamente ligado a la arquitectura, el hábitat y la sociedad. Fruto de nuestra pasión por el trabajo realizamos una constante investigación que analiza los últimos propuestas arquitectónicas, los sistemas constructivos y las nuevas tendencias en decoración y moda.

Desarrollamos gamas extensas, amplitud de formatos y colores, en OUTDOOR20 que ofrecen al proyectista múltiples opciones de colocación. Las últimas tendencias en suelos busca crear una sensación homogénea de orden y continuidad visual. En Rocersa contamos con porcelánicos que presentan diseños idénticos tanto en el interior como en el exterior, buscando esa continuidad. Diseños interiores que buscan difuminar la transición de un espacio a otro para generar una sensación visual de amplitud. Continuidad creada mediante el uso del mismo suelo para espacios más abiertos y versátiles, con características técnicas diferentes según sean de interior o de exterior.

*Our work is closely linked to architecture, habitat and society. As a result of our passion for our work, we carry out constant research that analyses the latest architectural proposals, construction systems and new trends in decoration and fashion.*

*We develop extensive ranges, a wide range of formats and colours, in OUTDOOR20 that offer the designer multiple laying options. The latest trends in flooring seek to create a homogeneous sensation of order and visual continuity. At Rocersa we have porcelain tiles with identical designs both indoors and outdoors, seeking this continuity. Interior designs that seek to blur the transition from one space to another to generate a visual sensation of spaciousness. Continuity created by using the same floor for more open and versatile spaces, with different technical characteristics depending on whether they are indoors or outdoors.*

10mm

20mm

→IN←OUT→Collection



# Wall10

8,7-10mm

Rocersa apuesta por la innovación y la tecnología, pero también aplica en sus colecciones las últimas técnicas en diseño para estar en la vanguardia del sector.

Posee una amplia gama de diferentes acabados materiales para dotar de un valor único a cada pieza. Hoy en día existe la posibilidad de que las paredes del hogar luzcan con todo tipo de revestimientos cerámicos aportando a los espacios mayor estilo y elegancia.

Las colecciones de revestimiento de 10mm de Rocersa acompañan pavimento coordinado en porcelánico dotando de mayor funcionalidad y completitud a cada serie.

*Rocersa is committed to innovation and technology, but also applies the latest design techniques in its collections to be at the forefront of the sector.*

*It has a wide range of different material finishes to give each piece a unique value. Nowadays, it is possible for the walls of the home to be decorated with all types of ceramic wall tiles, giving spaces greater style and elegance.*

*Rocersa's 10mm wall tile collections are accompanied by coordinated porcelain floor tiles, giving each series greater functionality and completeness.*

## Índice Index

### TIPOLOGÍA TYPOLOGY

MADERA WOOD		PIEDRA STONE		MÁRMOL MARBLE	
CUSTOM	18	AXIS	106	ARPEGIO	216
EVERGLOW	22	BURLINGTON	110	CALACATTA GOLD	220
FLOW	26	CHRONO	116	CAPRAIA	224
FORMENTERA	30	CITADEL	120	ELEGANZA	228
GLAMORA	34	CORALSTONE	124	KEA	234
ROTTERDAM	38	DOVER	128	MITRA	238
SOHO	42	EIFEL	132	OMBRA	242
		ESSENTIAL	136	RAFFAELLO	246
		ETERNAL STONE	140	SHADOW	250
		FOSSIL	144	SIENA	254
		HABITAT	148		
		HARDBLUE	152		
		KALOS	156		
		KINESIS	160		
		KORE	164		
		LEGACY	168		
		LIVERMORE	172		
		LUME	178		
		MATERIA	182		
		MOON	186		
		MUSE	190		
		NORTHBAY	194		
		SALISBURY	198		
		STONEHENGE	202		
		SUNSET	206		
		VALLEY	210		
CEMENTO CONCRETE				COLOR COLOUR	
BELFORT	48			ATMOSPHERE	260
CODE	52			BELLEZZA	264
CONCRETO	56			CLASH	268
CONTRACT	60			GROOVY	272
EXA	64			LIGHT	276
HACKNEY	68			SERENADE	280
MAKE UP	72				
MANHATTAN	76				
MENORCA	80				
METALART	84				
MUSTANG	88				
NOMADE	92				
SYNERGY	96				
TOWN	100				

# Índice

## Index

### FORMATOS

#### SIZES

#### 19,4x120 RC

EVERGLOW	22
FLOW	26
FORMENTERA	30

#### 20x60

BELLEZZA	264
BURLINGTON	110
CHRONO	116
CLASH	268
GROOVY	272
HABITAT	148
KORE	164
LIVERMORE	172
METALART	84
SERENADE	280
SUNSET	206

#### 20x120 RC

ROTTERDAM	38
-----------	----

#### 22,5x90

CUSTOM	18
SOHO	42
ROTTERDAM	38

#### 25x75

HACKNEY	68
LIGHT	276
LUME	178

#### 25x150

ROTTERDAM	38
-----------	----

#### 29,5x120 RC **OUTDOOR**

EVERGLOW	22
FLOW	26
GLAMORA	34
ROTTERDAM	38

#### 29,5x120 RC

GLAMORA	34
---------	----

#### 30x60 RC

CORALSTONE	124
FOSSIL	144
MOON	186
SALISBURY	198

#### 31,6x60,8

AXIS	106
BURLINGTON	110
CHRONO	116
CORALSTONE	124
DOVER	128
EIFEL	132
KINESIS	160
LIVERMORE	172
MAKE UP	72
MATERIA	182
NORTHBAY	194
SALISBURY	198
STONEHENGE	202
SUNSET	206
TOWN	100
VALLEY	210

#### 30,6x59,8 RC

KEA	234
-----	-----

#### 33x100 RC

CALACATTA GOLD	220
CAPRAIA	224
ELEGANZA	228
ESSENTIAL	136
EXA	64
KALOS	156
LIGHT	276
MANHATTAN	76
MATERIA	182
MENORCA	80
NOMADE	92
RAFFAELLO	246
SIENA	254

#### 40x120\_0,7 RC **VIKER**

ATMOSPHERE	260
LEGACY	168
MITRA	238
MUSE	190
NOMADE	92
SALISBURY	198

#### 47,2x47,2

BELFORT	48
BELLEZZA	264
BURLINGTON	110
CHRONO	116
GROOVY	272
HACKNEY	68
KORE	164
LIVERMORE	172
METALART	84
SUNSET	206

#### 60x60\_2 RC **OUTDOOR**

ARPEGGIO	216
AXIS	106
BELFORT	48
CHRONO	116
CORALSTONE	124
DOVER	128
ETERNAL STONE	140
FOSSIL	144
HARDBLUE	152
LIVERMORE	172
MATERIA	182
MOON	186
MUSTANG	88
NOMADE	92
SALISBURY	198
STONEHENGE	202
SYNERGY	96
VALLEY	210

#### 60x60

BELFORT	48
MATERIA	182
MUSTANG	88
SYNERGY	96

#### 60x60 RC

AXIS	106
CITADEL	120
CLASH	268
CORALSTONE	124
DOVER	128
ESSENTIAL	136
ETERNAL STONE	140
EXA	64
FOSSIL	144
HARDBLUE	152
KALOS	156
LEGACY	168
LIVERMORE	172
LUME	178
MAKE UP	72
MANHATTAN	76
MITRA	238
MOON	186
MUSE	190
MUSTANG	88
NOMADE	92
SALISBURY	198
STONEHENGE	202
VALLEY	210

#### 60x90\_2 RC **OUTDOOR**

ARPEGGIO	216
AXIS	106
BURLINGTON	110
CORALSTONE	124
NORTHBAY	194
SALISBURY	198
STONEHENGE	202
VALLEY	210

#### 60x90 RC

ARPEGGIO	216
AXIS	106
BURLINGTON	110
NORTHBAY	194
STONEHENGE	202
VALLEY	210

#### 60x120 RCP

CALACATTA GOLD	220
CAPRAIA	224
ELEGANZA	228
OMBRA	242
RAFFAELLO	246
SHADOW	250
SIENA	254

#### 60x120 RC

AXIS	106
BURLINGTON	110
CHRONO	116
CITADEL	120
CONCRETO	56
CONTRACT	60
CORALSTONE	124
DOVER	128
ETERNAL STONE	140
HARDBLUE	152
LIVERMORE	172
MAKE UP	72
MOON	186
NOMADE	92
NORTHBAY	194
SALISBURY	198
STONEHENGE	202
VALLEY	210

#### 60x120\_2 RC **OUTDOOR**

AXIS	106
CHRONO	116
CITADEL	120
CONTRACT	60
CORALSTONE	124
DOVER	128
HARDBLUE	152
LIVERMORE	172
MAKE UP	72
NOMADE	92
SALISBURY	198
STONEHENGE	202
VALLEY	210

#### 61x61\_2 **OUTDOOR**

AXIS	106
------	-----

#### 75x75\_2 RC **OUTDOOR**

BELFORT	48
CITADEL	120
DOVER	128
MATERIA	182
MUSTANG	88

#### 75x75 RC

BELFORT	48
CITADEL	120
DOVER	128
LIVERMORE	172
MATERIA	182
MUSTANG	88
NORTHBAY	194

#### 75x150 RCP

CALACATTA GOLD	220
CAPRAIA	224
ELEGANZA	228
OMBRA	242
RAFFAELLO	246
SHADOW	250
SIENA	254

#### 100x100\_2 RC **OUTDOOR**

AXIS	106
BURLINGTON	110
CONCRETO	56
CORALSTONE	124
DOVER	128
ETERNAL STONE	140
FOSSIL	144
HARDBLUE	152
LIVERMORE	172
MAKE UP	72
MOON	186
NOMADE	92
NORTHBAY	194
SALISBURY	198
VALLEY	210

#### 100x100 RC

AXIS	106
BURLINGTON	110
CONCRETO	56
CORALSTONE	124
DOVER	128
ETERNAL STONE	140
FOSSIL	144
HARDBLUE	152
LIVERMORE	172
MAKE UP	72
MOON	186
NOMADE	92
NORTHBAY	194
SALISBURY	198
VALLEY	210

#### 120x120 RCP

CALACATTA GOLD	220
CAPRAIA	224
ELEGANZA	228
OMBRA	242
RAFFAELLO	246
SHADOW	250
SIENA	254

ALFABÉTICO  
ALPHABETICAL

<b>A</b>	ARPEGGIO	216	<b>K</b>	KALOS	156
	ATMOSPHERE	260		KEA	234
	AXIS	106		KINESIS	160
<b>B</b>	BELFORT	48		KORE	164
	BELLEZZA	264	<b>L</b>	LEGACY	168
	BURLINGTON	110		LIGHT	276
<b>C</b>	CALACATTA GOLD	220		LIVERMORE	172
	CAPRAIA	224		LUME	178
	CHRONO	116	<b>M</b>	MAKE UP	72
	CITADEL	120		MANHATTAN	76
	CLASH	268		MATERIA	182
	CODE	52		MENORCA	80
	CONCRETO	56		METALART	84
	CONTRACT	60		MITRA	238
	CORALSTONE	124		MOON	186
	CUSTOM	18		MUSE	190
<b>D</b>	DOVER	128		MUSTANG	88
<b>E</b>	EIFEL	132	<b>N</b>	NOMADE	92
	ELEGANZA	228		NORTHBAY	194
	ESSENTIAL	136	<b>O</b>	OMBRA	242
	ETERNAL STONE	140	<b>R</b>	RAFFAELLO	246
	EVERGLOW	22		ROTTERDAM	38
	EXA	64	<b>S</b>	SALISBURY	198
<b>F</b>	FLOW	26		SERENADE	280
	FORMENTERA	30		SHADOW	250
	FOSSIL	144		SIENA	254
<b>G</b>	GLAMORA	34		SOHO	42
	GROOVY	272		STONEHENGE	202
<b>H</b>	HABITAT	148		SUNSET	206
	HACKNEY	68		SYNERGY	96
	HARDBLUE	152	<b>T</b>	TOWN	100
			<b>V</b>	VALLEY	210

SIMBOLOGÍA  
SYMBOLOLOGY

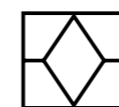

DISPONIBLE EN HIDROCORTE  
HYDROCUTTING AVAILABLE



DESTONIFICACIÓN  
SHADING VARIATIONS



UNIFORME  
UNIFORM



LIGERA  
SLIGHT



MODERADA  
MODERATED



CONSIDERABLE  
SUBSTANCIAL

BIM  
LIBRARY

PUEDES DESCARGAR NUESTRAS COLECCIONES EN [WWW.ROCERSA.COM/BIM](http://WWW.ROCERSA.COM/BIM)  
YOU CAN DOWNLOAD OUR COLLECTIONS AT [WWW.ROCERSA.COM/BIM](http://WWW.ROCERSA.COM/BIM)

SIMBOLOGÍA CONSUMO DE MATERIALES RECICLADOS  
SYMBOLOLOGY OF CONSUMPTION OF RECYCLED MATERIAL

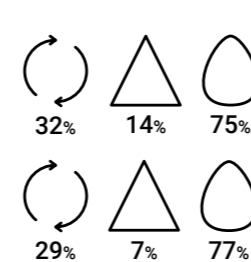

CONTENIDO MÍNIMO DE MATERIAL RECICLADO  
MINIMUM PRE-CONSUMER RECYCLED MATERIAL CONTENT



REDUCCIÓN DE CONSUMO DE MINERALES  
MINERAL REDUCTION

REDUCCIÓN DE CONSUMO DE AGUA  
WATER REDUCTION

CLASIFICACIÓN POR COLORES  
COLOR CLASSIFICATION

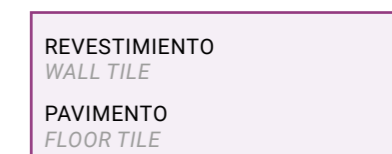
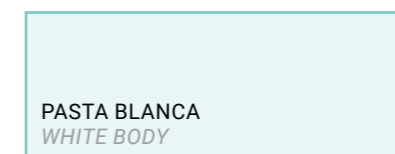
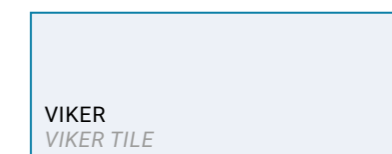
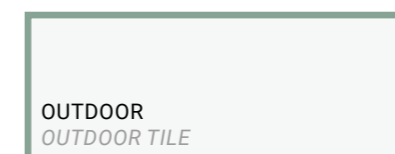

La reproducción de los colores es aproximada debido a los sistemas de impresión. Los códigos de precios y las referencias deben verificarse ya que pueden haber errores tipográficos. El fabricante se reserva el derecho de modificar las características del packing según las condiciones del pedido.

*Given the printing systems in use, the colours reproduced herein are roughly equivalent to actual ones. Price code and product codes should be checked since there be typographical errors. The manufacturer reserves the right to modify the characteristics as per the terms and conditions of the order.*

Colores  
Colours

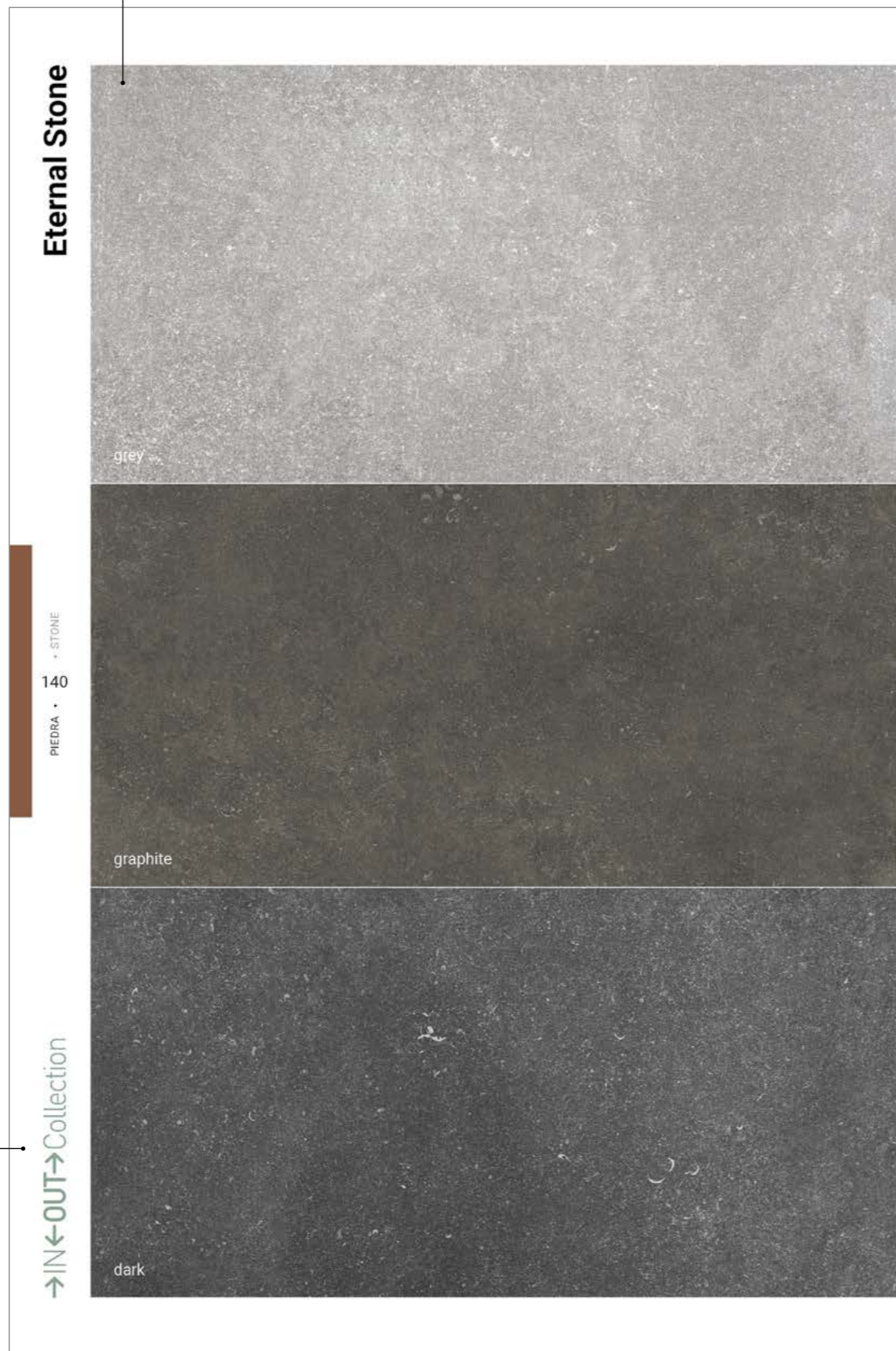

Características especiales de la colección  
Special features of the collection

Serie  
Serie

Propiedades  
Properties

Imagen serie  
Image of the serie

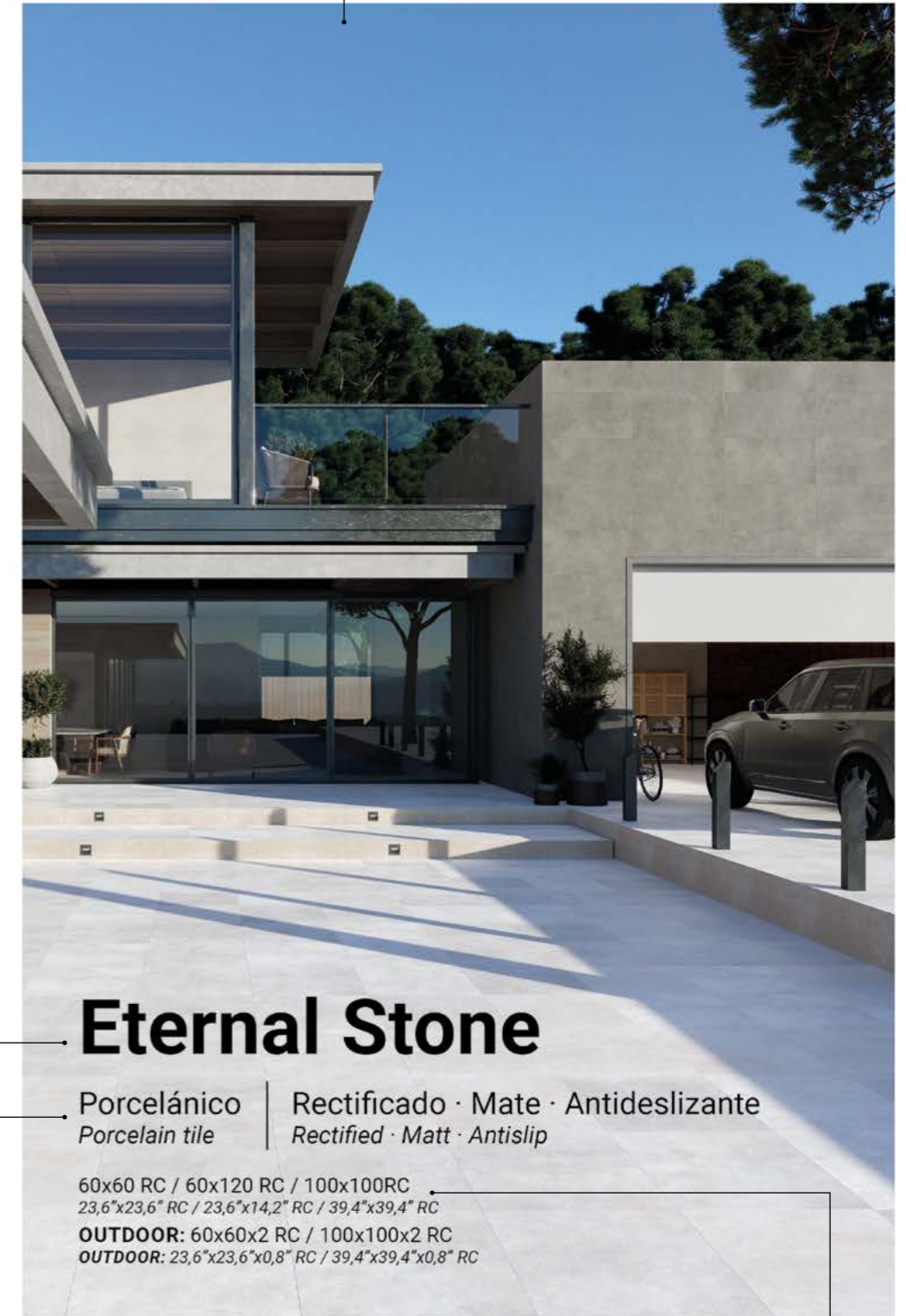

Formatos  
Sizes



**Eternal Stone**

FORMATOS DISPONIBLES  
AVAILABLE SIZES

ETERNAL STONE GREY CTE1/R9 / B226  
ETERNAL STONE GRAPHITE CTE1/R9 / B226  
ETERNAL STONE DARK CTE1/R9 / B226

60 x 60 RC

60 x 60 x 2 RC

ETERNAL STONE 20 GREY CTE3/R11/C / B410  
ETERNAL STONE 20 GRAPHITE CTE3/R11/C / B410  
ETERNAL STONE 20 DARK CTE3/R11/C / B410

100 x 100 RC

100 x 100 x 2 RC

ETERNAL STONE GREY CTE1/R9 / B310  
ETERNAL STONE GREY CTE3/R11/C / B310  
ETERNAL STONE GRAPHITE CTE1/R9 / B310  
ETERNAL STONE GRAPHITE CTE3/R11/C / B310  
ETERNAL STONE DARK CTE1/R9 / B310  
ETERNAL STONE DARK CTE3/R11/C / B310

60 x 120 RC

ETERNAL STONE GREY CTE1/R9 / B310  
ETERNAL STONE GRAPHITE CTE1/R9 / B310  
ETERNAL STONE DARK CTE1/R9 / B310

EJEMPLO DE VARIEDAD GRÁFICA  
GRAPHIC VARIETY EXAMPLE

ETERNAL STONE GRAPHITE 60x120 RC  
ETERNAL STONE GRAPHITE 23,6" x 47,2" RC

Características especiales de la colección  
Special features of the collection

Simbología  
Symbology

Piezas complementarias de la serie  
Complementary pieces of the series

Imagen de pieza  
Tile image

COMPLEMENTOS  
ACCESSORIES

MS ETERNAL STONE GREY 30x30 / C65

MS ETERNAL STONE GRAPHITE 30x30 / C65

MS ETERNAL STONE DARK 30x30 / C65

ETERNAL STONE GREY  
Descripción  
Description  
B310  
ID Precio  
Price ID

Variedad gráfica de la serie  
Graphic variety of the series

Imagen serie  
Image of the serie

Pie de foto  
Caption

→ IN ← OUT → Collection

→ IN ← OUT → Collection

**Eternal Stone**

ETERNAL STONE 20 GREY CTE3/R11/C / B600  
ETERNAL STONE 20 GRAPHITE CTE3/R11/C / B600  
ETERNAL STONE 20 DARK CTE3/R11/C / B600

ETERNAL STONE 20 DARK 100x100 RC

Imagen serie  
Image of the serie

Pie de foto  
Caption

→ IN ← OUT → Collection



**MADERA**  
*WOOD*



pearl



grey



nature



walnut

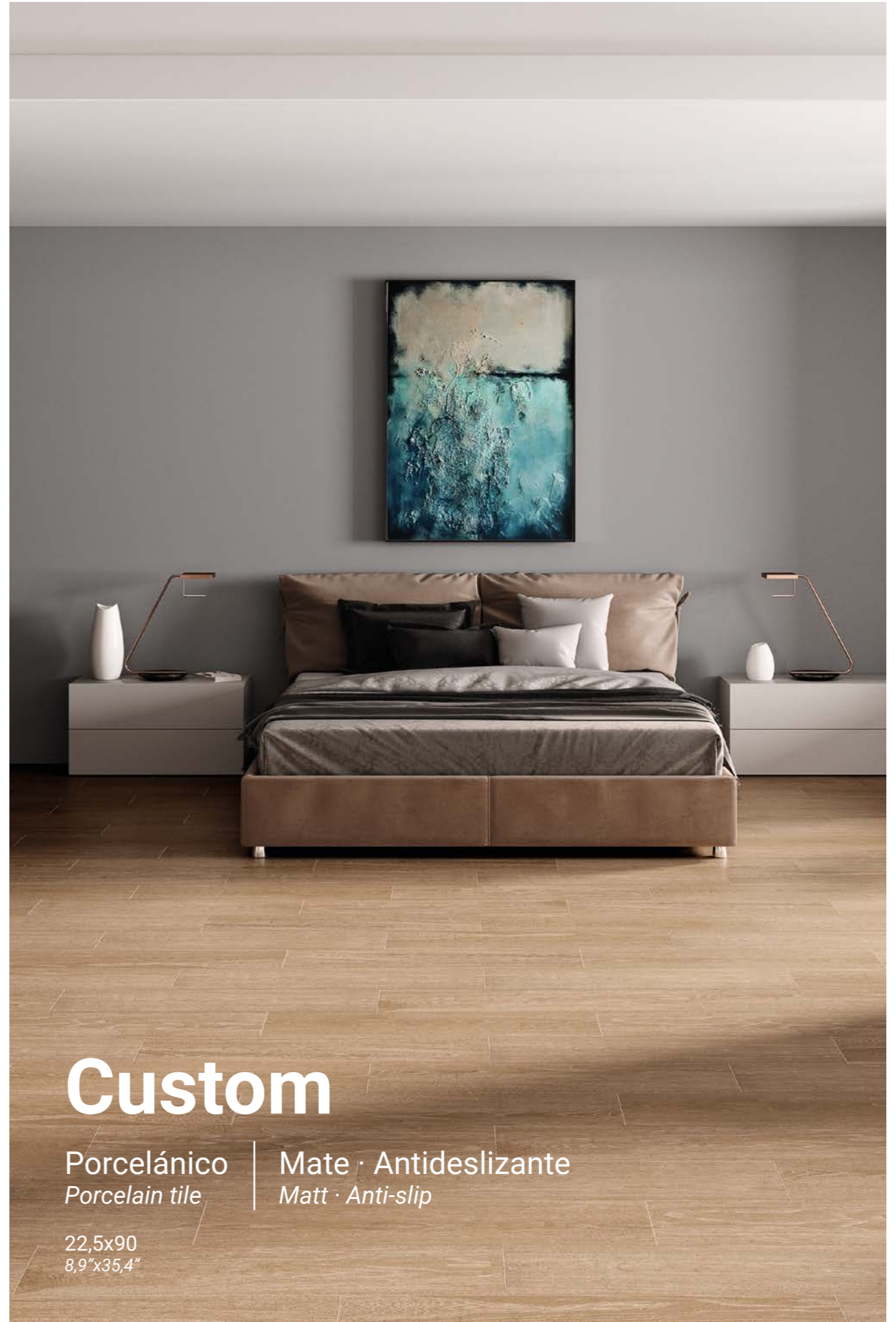

# Custom

Porcelánico  
Porcelain tile

Mate · Antideslizante  
Matt · Anti-slip

22,5x90  
8,9"x35,4"

FORMATOS DISPONIBLES  
AVAILABLE SIZES

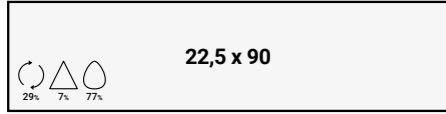

- CUSTOM PEARL CTE1/R9 / B150
- CUSTOM GREY CTE1/R9 / B150
- CUSTOM GREY CTE3/R11/C / B150
- CUSTOM NATURE CTE1/R9 / B150
- CUSTOM NATURE CTE3/R11/C / B150
- CUSTOM WALLNUT CTE1/R9 / B150

EJEMPLO DE VARIEDAD GRÁFICA  
GRAPHIC VARIETY EXAMPLE

CUSTOM WALLNUT 22,5x90  
CUSTOM WALLNUT 8,9 x35,4"

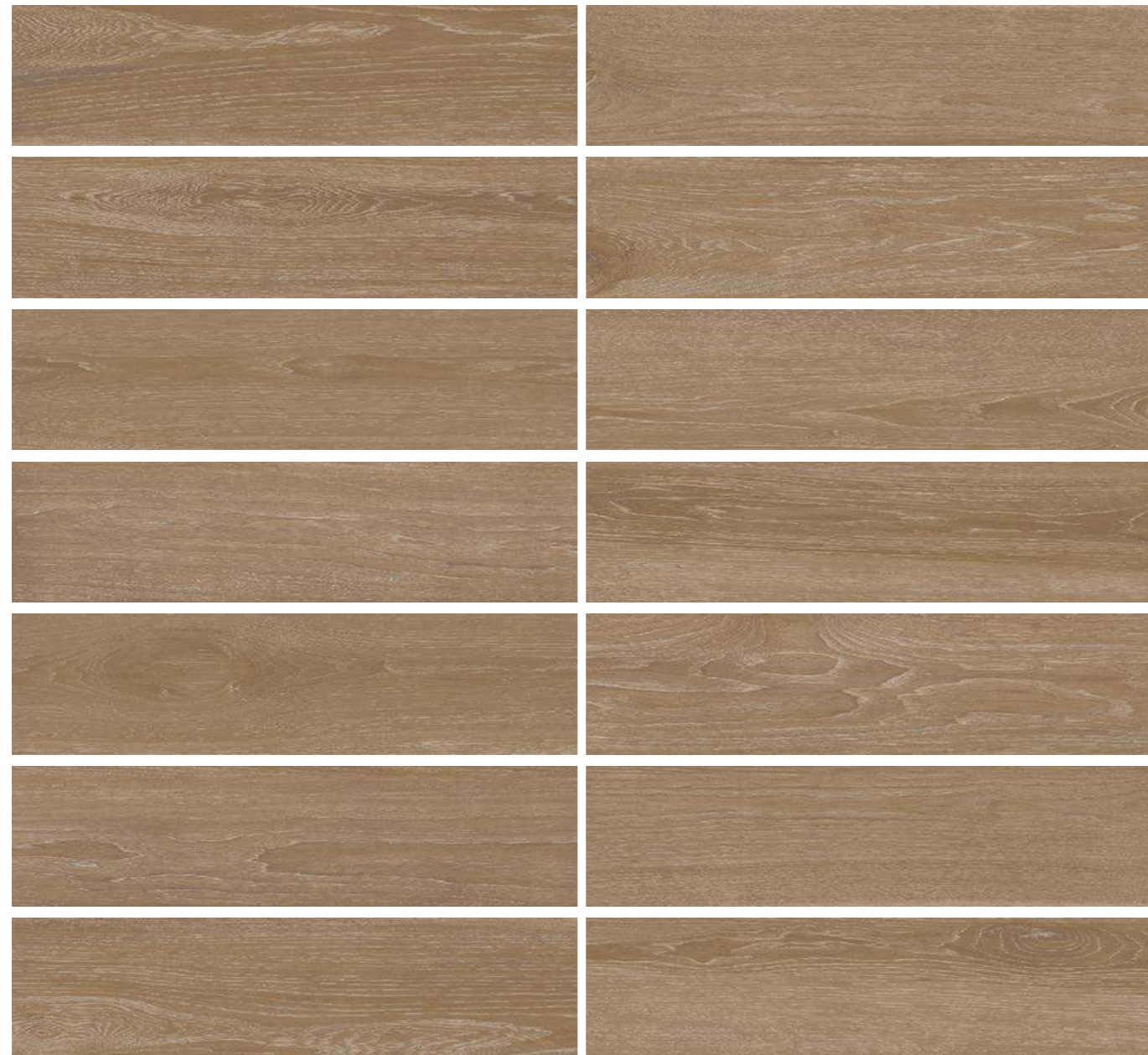

CUSTOM GREY 22,5x90



white

grey

dark

nature

ash

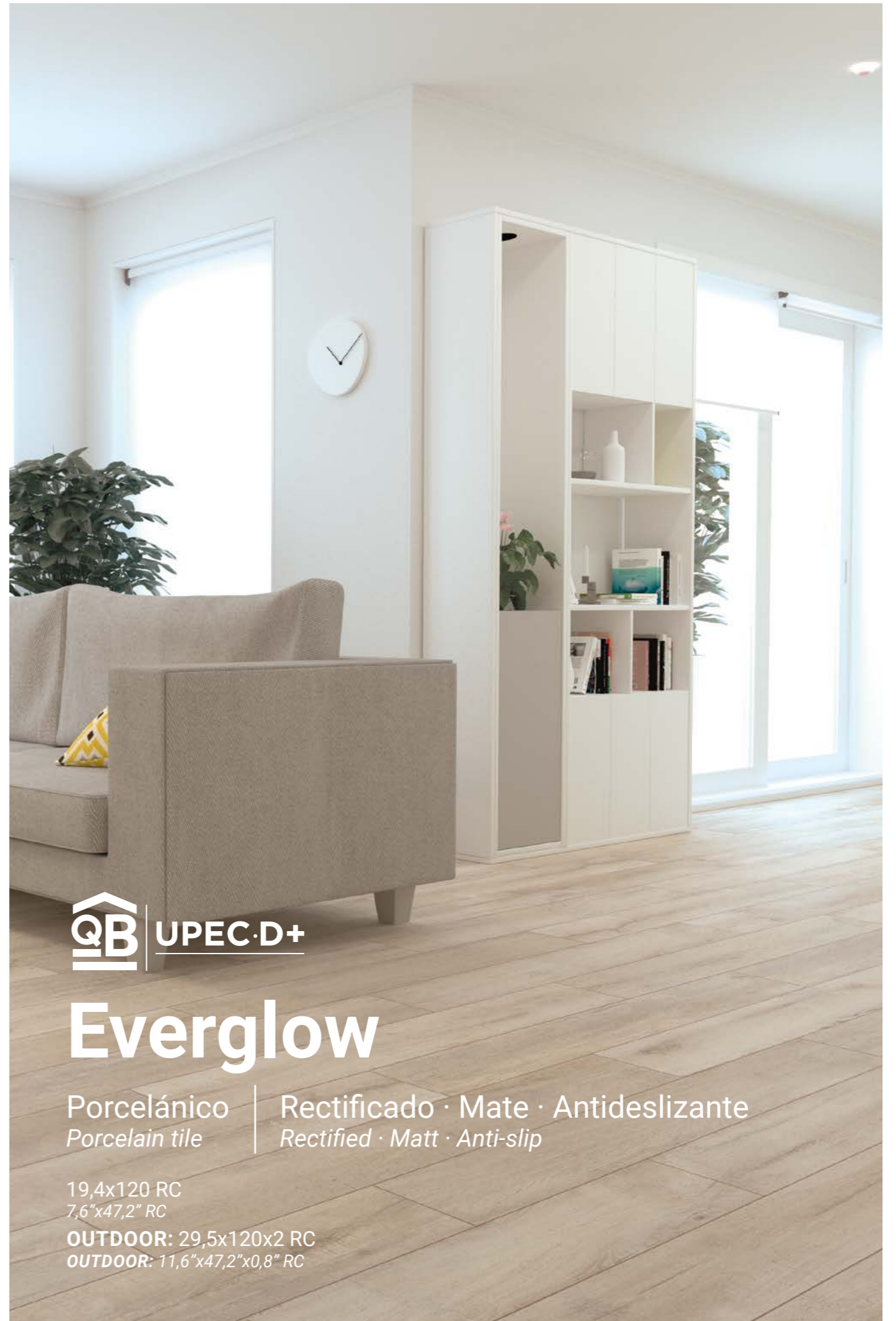

**QB** UPEC·D+

# Everglow

Porcelánico  
Porcelain tile

Rectificado · Mate · Antideslizante  
Rectified · Matt · Anti-slip

19,4x120 RC  
7,6"x47,2" RC

**OUTDOOR:** 29,5x120x2 RC  
**OUTDOOR:** 11,6"x47,2"x0,8" RC

**19,4 x 120 RC**

- EVERGLOW WHITE CTE1 / B298
- EVERGLOW GREY CTE1 / B298
- EVERGLOW GREY CTE3/R11/C / B298
- EVERGLOW DARK CTE1 / B298
- EVERGLOW NATURE CTE1 / B298
- EVERGLOW NATURE CTE3/R11/C / B298
- EVERGLOW ASH CTE1 / B298
- EVERGLOW ASH CTE3/R11/C / B298

**29,5 x 120 x 2 RC**

- EVERGLOW 20 WHITE CTE3/R11/C / B600
- EVERGLOW 20 GREY CTE3/R11/C / B600
- EVERGLOW 20 DARK CTE3/R11/C / B600
- EVERGLOW 20 NATURE CTE3/R11/C / B600
- EVERGLOW 20 ASH CTE3/R11/C / B600

EJEMPLO DE VARIEDAD GRÁFICA  
GRAPHIC VARIETY EXAMPLE

EVERGLOW NATURE 19,4x120 RC  
EVERGLOW NATURE 7,6"x47,2" RC

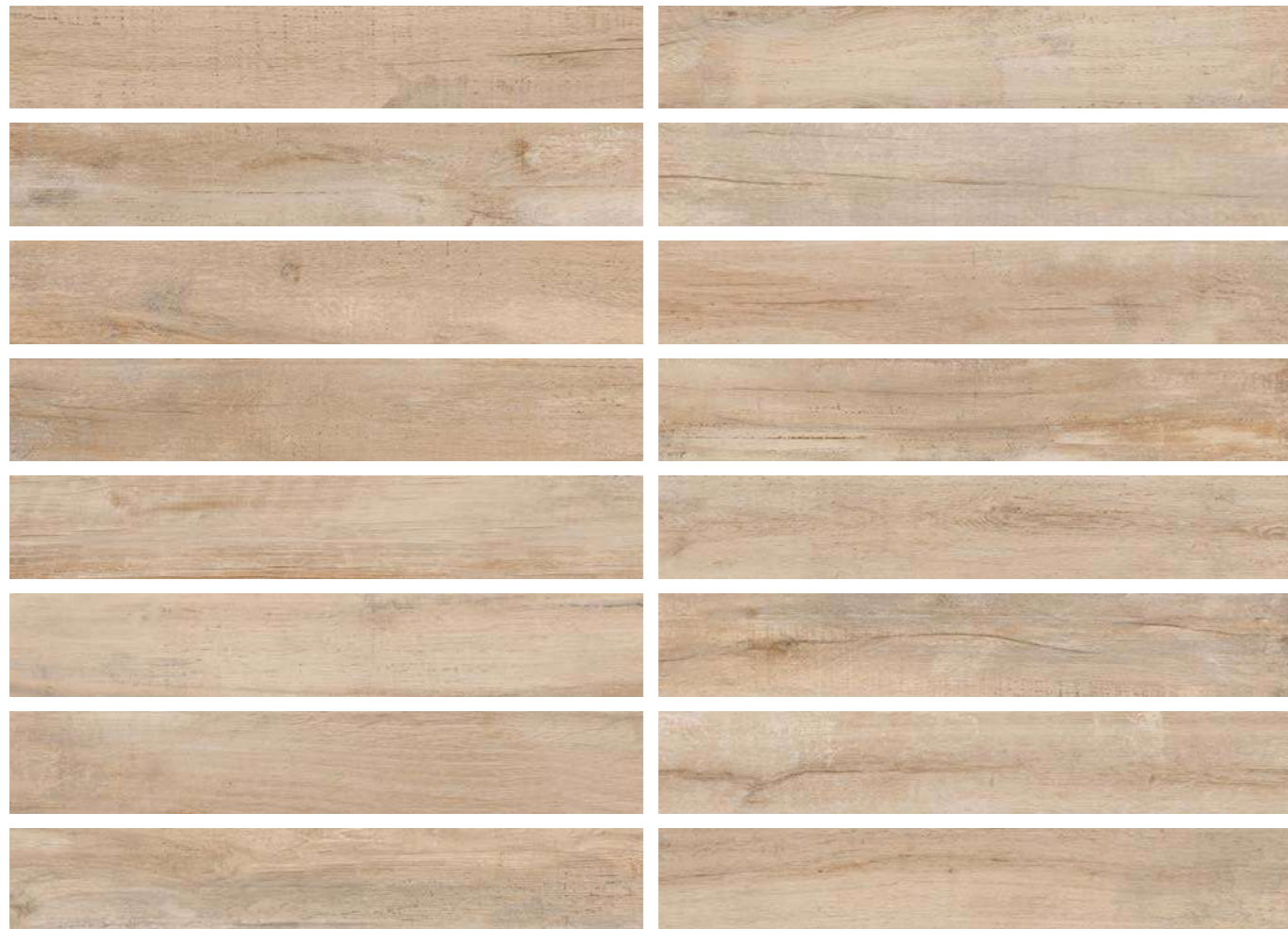

EVERGLOW 20 ASH 29,5x120 RC



QB UPEC·D+

# Flow

Porcelánico  
Porcelain tile

Rectificado · Mate · Antideslizante  
Rectified · Matt · Anti-slip

19,4x120 RC  
7,6"x47,2" RC

**OUTDOOR:** 29,5x120x2 RC  
**OUTDOOR:** 11,6"x47,2"x0,8" RC

OUTDOOR

**19,4 x 120 RC**

- FLOW WHITE CTE1 / B298
- FLOW LIGHT CTE1 / B298
- FLOW LIGHT CTE3/R11/C / B298
- FLOW SMOKE CTE1 / B298
- FLOW SMOKE CTE3/R11/C / B298
- FLOW MINK CTE1 / B298
- FLOW NATURE CTE1 / B298
- FLOW NATURE CTE3/R11/C / B298

**29,5 x 120 x 2 RC**

- FLOW 20 WHITE CTE3/R11/C / B600
- FLOW 20 LIGHT CTE3/R11/C / B600
- FLOW 20 SMOKE CTE3/R11/C / B600
- FLOW 20 MINK CTE3/R11/C / B600
- FLOW 20 NATURE CTE3/R11/C / B600

EJEMPLO DE VARIEDAD GRÁFICA  
GRAPHIC VARIETY EXAMPLE

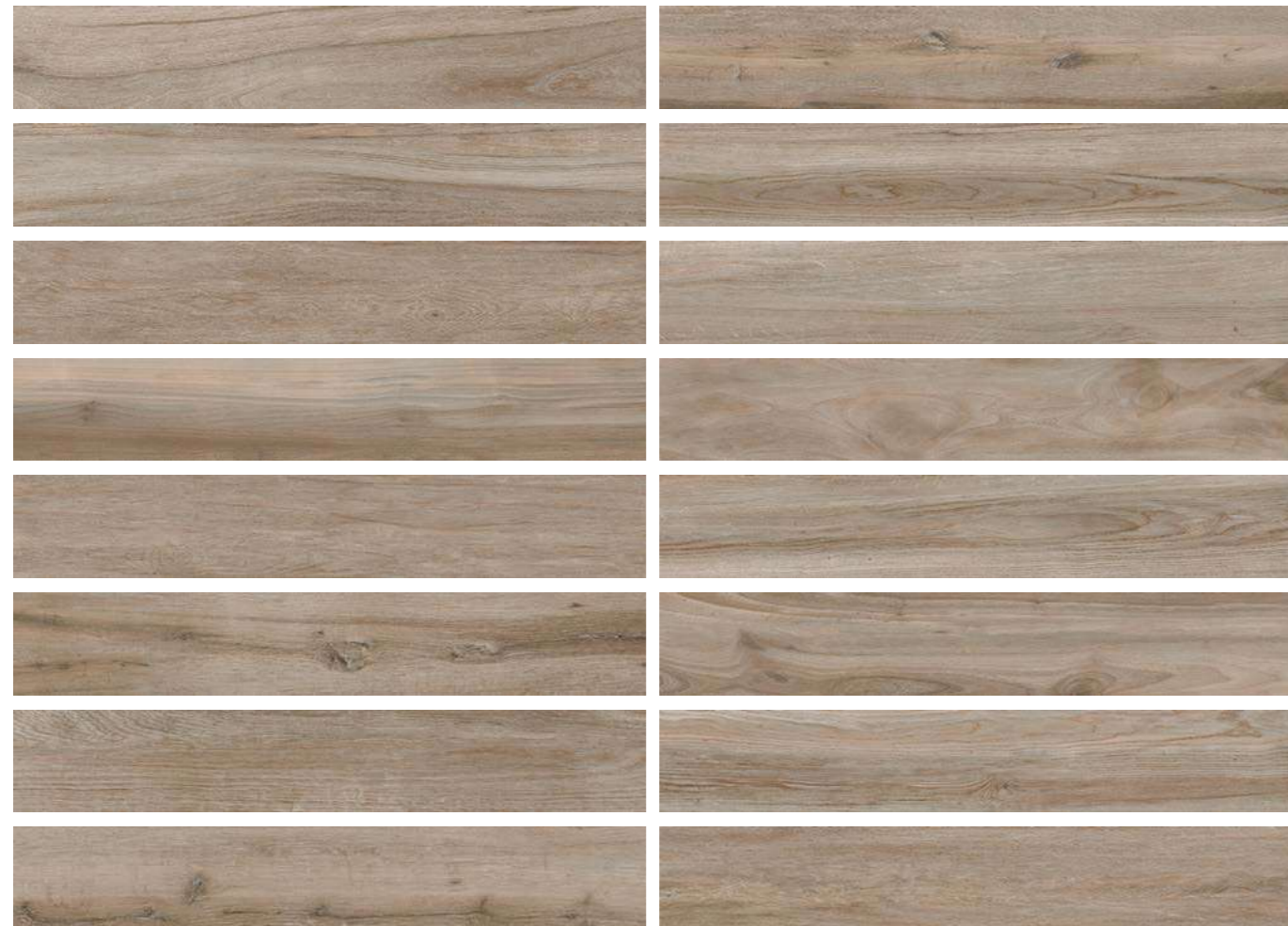

FLOW NATURE 19,4x120 RC  
FLOW NATURE 7,6"x47,2" RC



FLOW NATURE 19,4x120 RC





haya



roble



cerezo



nogal



# Formentera

Porcelánico  
*Porcelain tile*

Rectificado · Mate · Antideslizante  
*Rectified · Matt · Anti-slip*

19,4x120 RC  
7,6"x47,2" RC

FORMATOS DISPONIBLES  
AVAILABLE SIZES



- FORMENTERA HAYA CTE1 / B298
- FORMENTERA ROBLE CTE1 / B298
- FORMENTERA ROBLE CTE3/R11/C / B298
- FORMENTERA CEREZO CTE1 / B298
- FORMENTERA NOGAL CTE1 / B298
- FORMENTERA NOGAL CTE3/R11/C / B298

EJEMPLO DE VARIEDAD GRÁFICA  
GRAPHIC VARIETY EXAMPLE

FORMENTERA NOGAL 19,4x120 RC  
FORMENTERA NOGAL 7,6"x47,2" RC



FORMENTERA ROBLE 19,4x120 RC

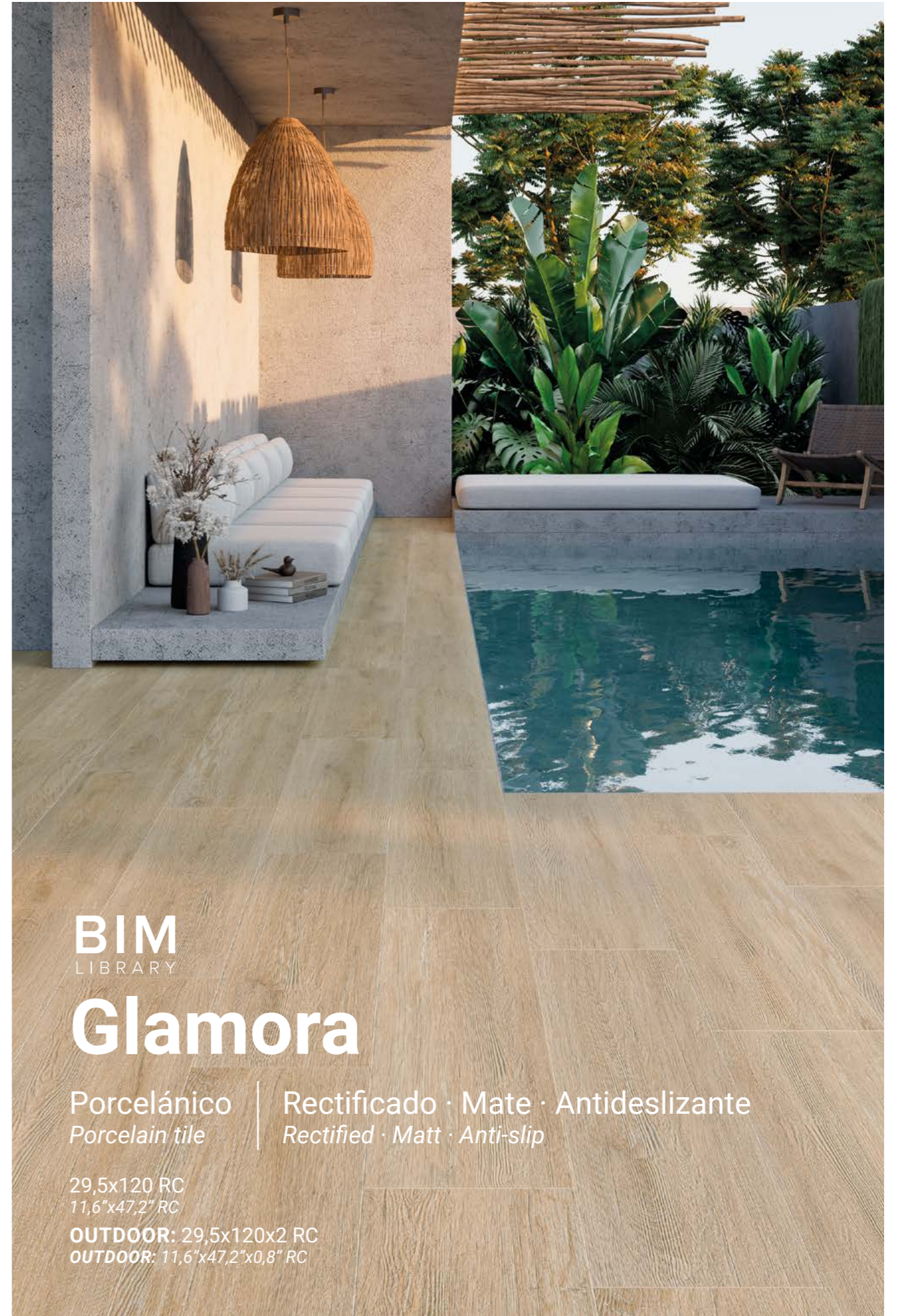

BIM  
LIBRARY

# Glamora

Porcelánico  
*Porcelain tile*

Rectificado · Mate · Antideslizante  
*Rectified · Matt · Anti-slip*

29,5x120 RC  
11,6"x47,2" RC

**OUTDOOR:** 29,5x120x2 RC  
**OUTDOOR:** 11,6"x47,2"x0,8" RC

OUTDOOR 20<sup>EE</sup>

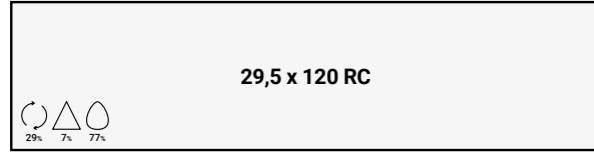

GLAMORA BIANCO CTE1/R9 / B310  
GLAMORA BIANCO CTE3/R11/C / B310  
GLAMORA GRIGIO CTE1/R9 / B310  
GLAMORA GRIGIO CTE3/R11/C / B310  
GLAMORA ROVERE CTE1/R9 / B310  
GLAMORA ROVERE CTE3/R11/C / B310  
GLAMORA NATURE CTE1/R9 / B310  
GLAMORA NATURE CTE3/R11 / B310

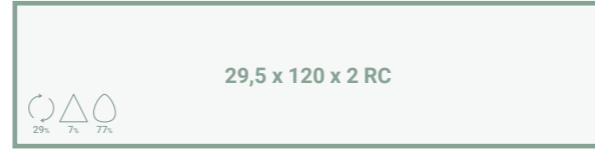

GLAMORA 20 BIANCO CTE3/R11/C / B600  
GLAMORA 20 GRIGIO CTE3/R11/C / B600  
GLAMORA 20 ROVERE CTE3/R11/C / B600  
GLAMORA 20 NATURE CTE3/R11/C / B600

EJEMPLO DE VARIEDAD GRÁFICA  
GRAPHIC VARIETY EXAMPLE

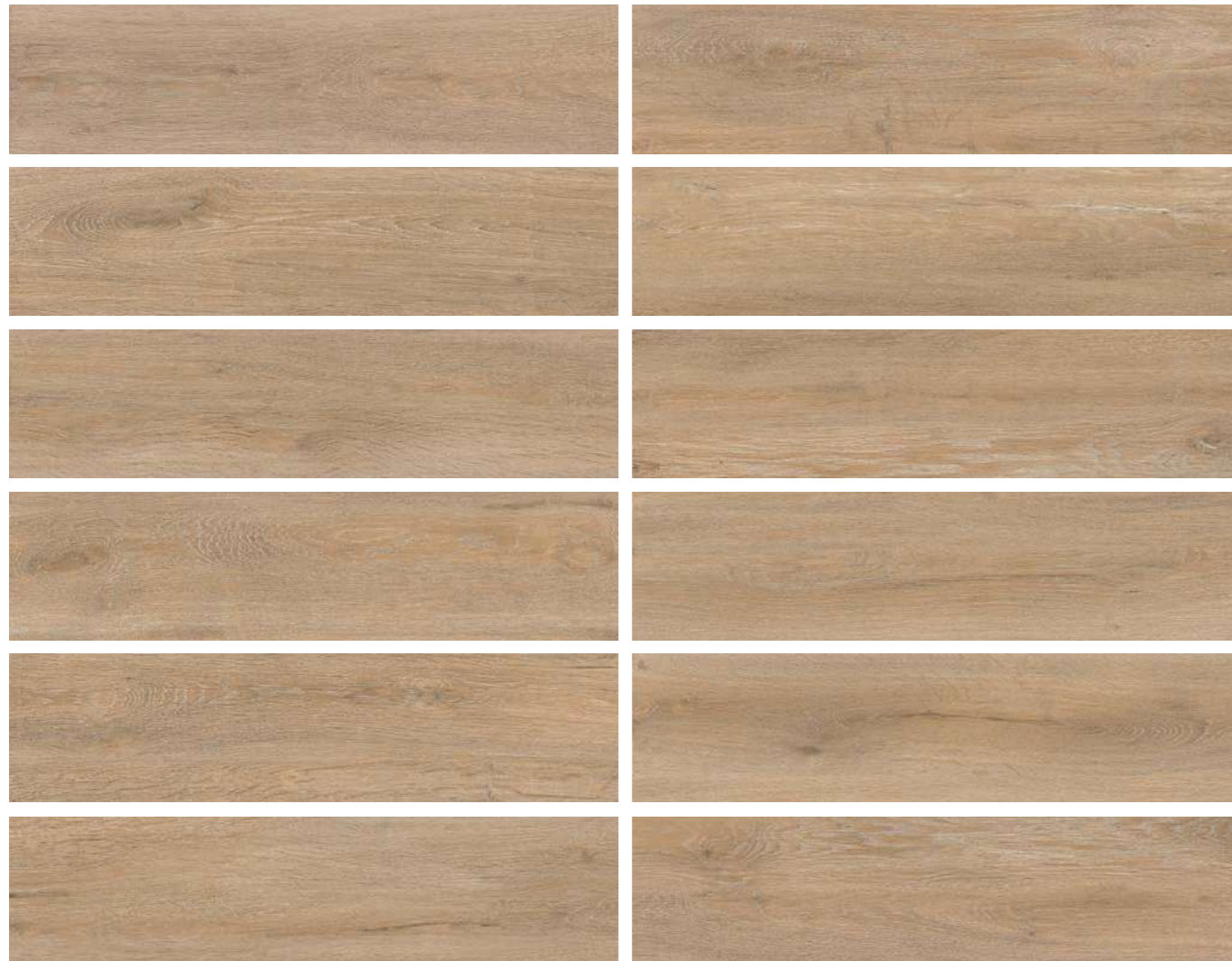

GLAMORA ROVERE 29,5x120 RC  
GLAMORA ROVERE 11,6"x47,2" RC



GLAMORA ROVERE 29,5x120 RC

haya

rovere

noce

nature

grey



# Rotterdam

Porcelánico  
Porcelain tile

Rectificado · Mate  
Rectified · Matt

22,5x90 / 25x150 RC / 20x120 RC  
9"x36" / 10"x60" RC / 7,9"x47,2" RC

**PASTA BLANCA:** 33x100 RC  
**WHITE BODY:** 13"x39,4" RC

**OUTDOOR:** 29,5x120x2 RC  
**OUTDOOR:** 11,6"x47,2"x0,8" RC

OUTDOOR 20<sup>EE</sup>



ROTTERDAM REL HAYA / B230  
ROTTERDAM REL ROVERE / B230  
ROTTERDAM REL NOCE / B230  
ROTTERDAM REL NATURE / B230  
ROTTERDAM REL GREY / B230

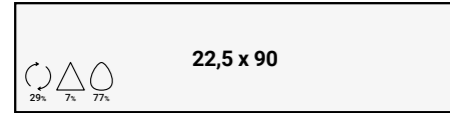

ROTTERDAM HAYA CTE1/R10 / B150  
ROTTERDAM ROVERE CTE1/R10 / B150  
ROTTERDAM NOCE CTE1/R10 / B150  
ROTTERDAM NATURE CTE1/R10 / B150  
ROTTERDAM GREY CTE1/R9 / B150

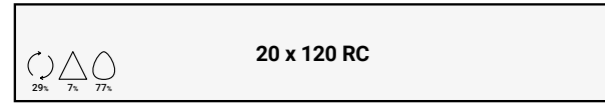

ROTTERDAM HAYA CTE1/R10 / B298  
ROTTERDAM ROVERE CTE1/R10/A / B298  
ROTTERDAM NOCE CTE1/R10/A / B298  
ROTTERDAM NATURE CTE1/R10/A / B298  
ROTTERDAM GREY CTE1/R9 / B298

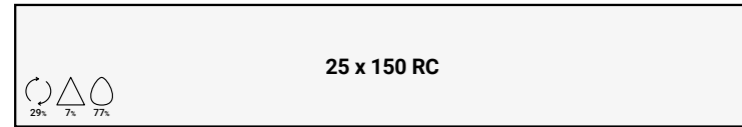

ROTTERDAM HAYA CTE1/R9/A / B333  
ROTTERDAM ROVERE CTE1/R9/A / B333  
ROTTERDAM NOCE CTE1/R9/A / B333  
ROTTERDAM NATURE CTE1/R9/A / B333  
ROTTERDAM GREY CTE1/R9/A / B333

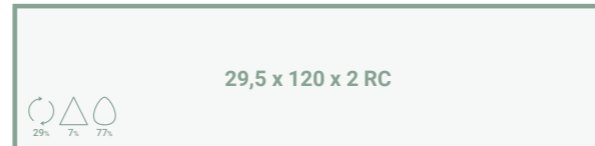

ROTTERDAM 20 HAYA CTE3/R11/A / B310  
ROTTERDAM 20 ROVERE CTE3/R11/A / B310  
ROTTERDAM 20 NOCE CTE3/R11/A / B310  
ROTTERDAM 20 NATURE CTE3/R11/A / B310  
ROTTERDAM 20 GREY CTE3/R11/A / B310

EJEMPLO DE VARIEDAD GRÁFICA  
GRAPHIC VARIETY EXAMPLE

ROTTERDAM ROVERE 22,5x90  
ROTTERDAM ROVERE 8,9"x35,4"



ROTTERDAM REL HAYA  
33x100 RC / B230



ROTTERDAM REL ROVERE  
33x100 RC / B230



ROTTERDAM REL NOCE  
33x100 RC / B230



ROTTERDAM REL GREY  
33x100 RC / B230



ROTTERDAM REL NATURE  
33x100 RC / B230

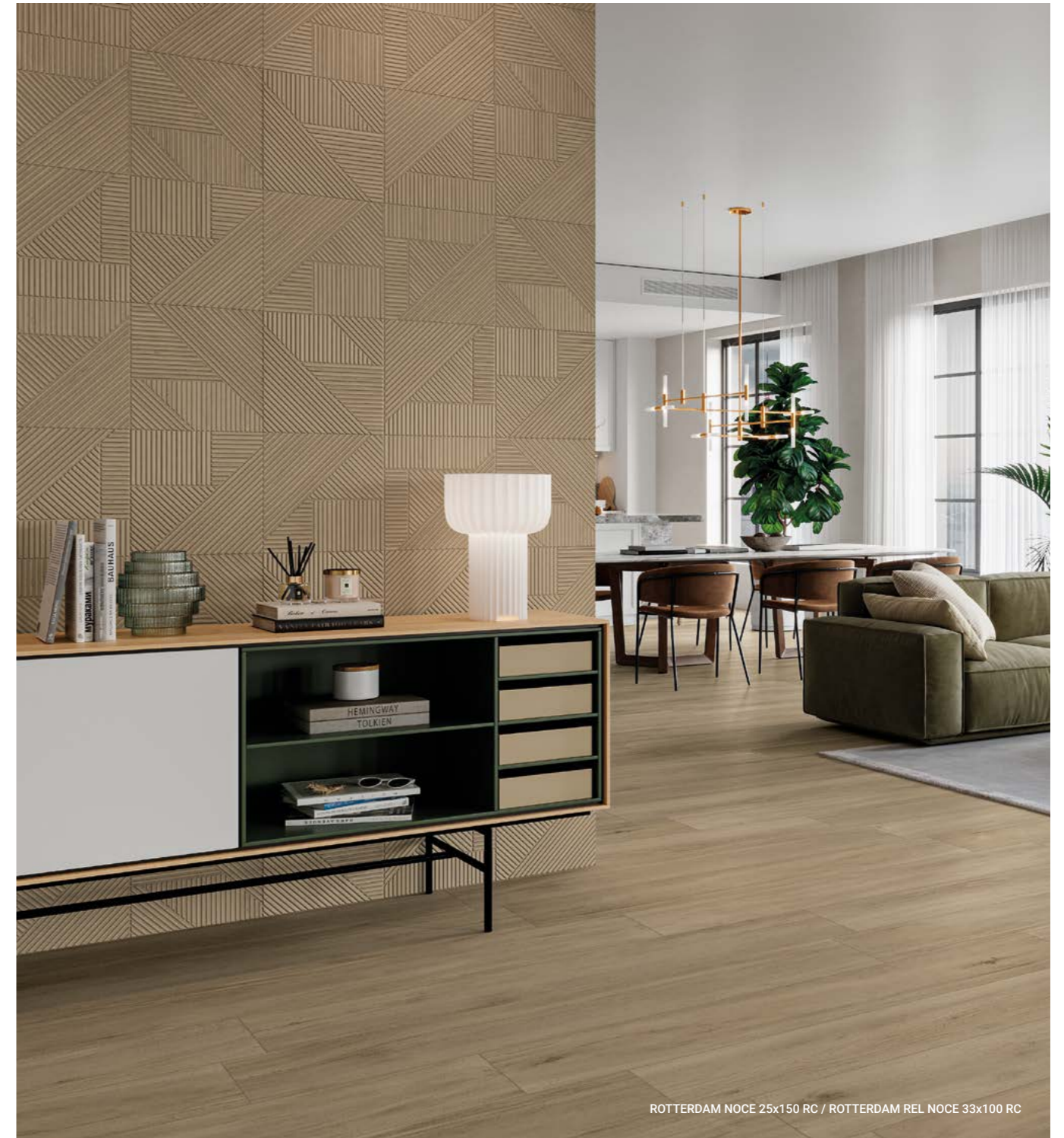

ROTTERDAM NOCE 25x150 RC / ROTTERDAM REL NOCE 33x100 RC



# Soho

Porcelánico  
*Porcelain tile*

Mate · Antideslizante  
*Matt · Anti-slip*

22,5x90  
8,9"x35,4"

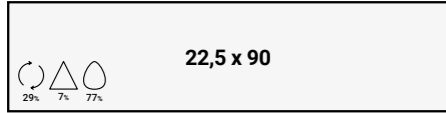

- SOHO WHITE CTE1/R9 / B150
- SOHO GREY CTE1/R9 / B150
- SOHO GREY CTE3/R11/C / B150
- SOHO CALIZA CTE1/R9 / B150
- SOHO OAK CTE1/R9 / B150
- SOHO OAK CTE3/R11/C / B150
- SOHO TAUPE CTE1/R9 / B150

EJEMPLO DE VARIEDAD GRÁFICA  
GRAPHIC VARIETY EXAMPLE

SOHO TAUPE 22,5x90  
SOHO TAUPE 8,9"x35,4"



SOHO OAK 22,5x90





**CEMENTO**  
*CONCRETE*



# Belfort

Porcelánico  
Porcelain tile

Rectificado · Mate  
Rectified · Matt

47,2x47,2 / 60x60 / 75x75 RC  
18,9"x18,9" / 23,6"x23,6" / 29,5"x29,5" RC

**OUTDOOR:** 60x60x2 RC / 75x75x2 RC  
**OUTDOOR:** 23,6"x23,6"x0,8" RC / 29,5"x29,5"x0,8" RC

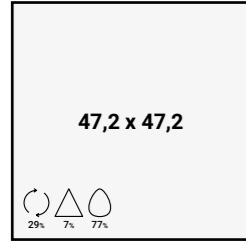

BELFORT GRIS / B186  
BELFORT GRAFITO / B186

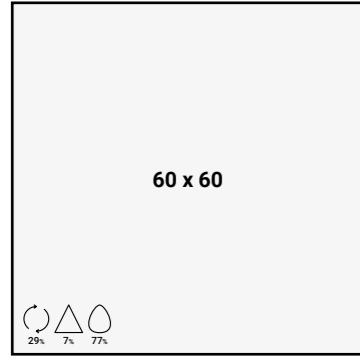

BELFORT BLANCO / B208  
BELFORT TOSTADO / B208  
BELFORT GRIS / B208



BELFORT 20 GRIS CTE3/R11/C / B410  
BELFORT 20 GRAFITO CTE3/R11/C / B410

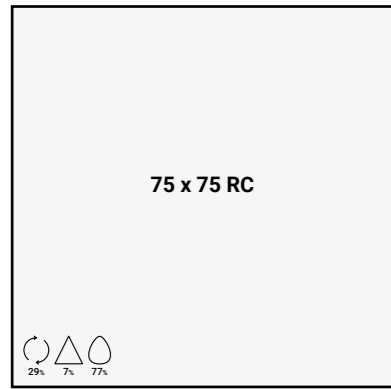

BELFORT BLANCO / B273  
BELFORT TOSTADO / B273  
BELFORT GRIS / B273  
BELFORT GRAFITO / B273



BELFORT 20 GRIS CTE3/R11/C / B524  
BELFORT 20 GRAFITO CTE3/R11/C / B524

EJEMPLO DE VARIEDAD GRÁFICA  
GRAPHIC VARIETY EXAMPLE

BELFORT TOSTADO 60x60  
BELFORT TOSTADO 23,6"x23,6"



BELFORT 20 GRIS 60x60 RC

white

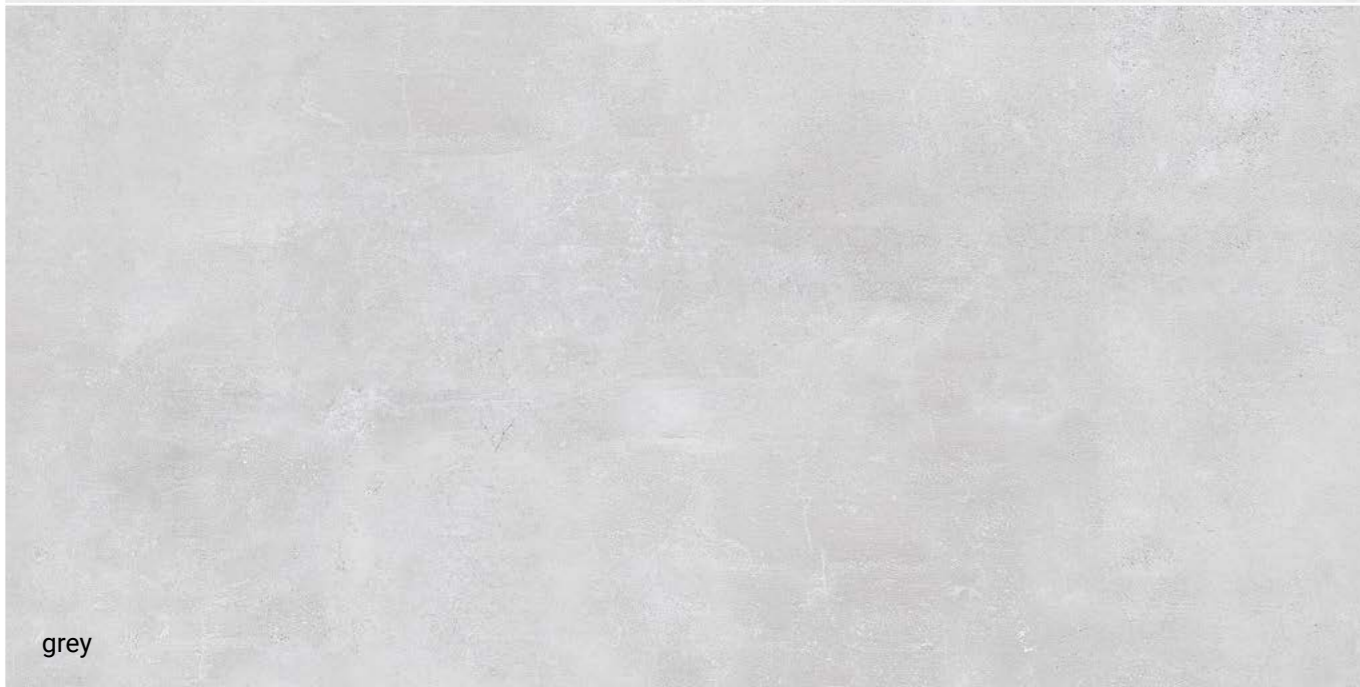

grey



black

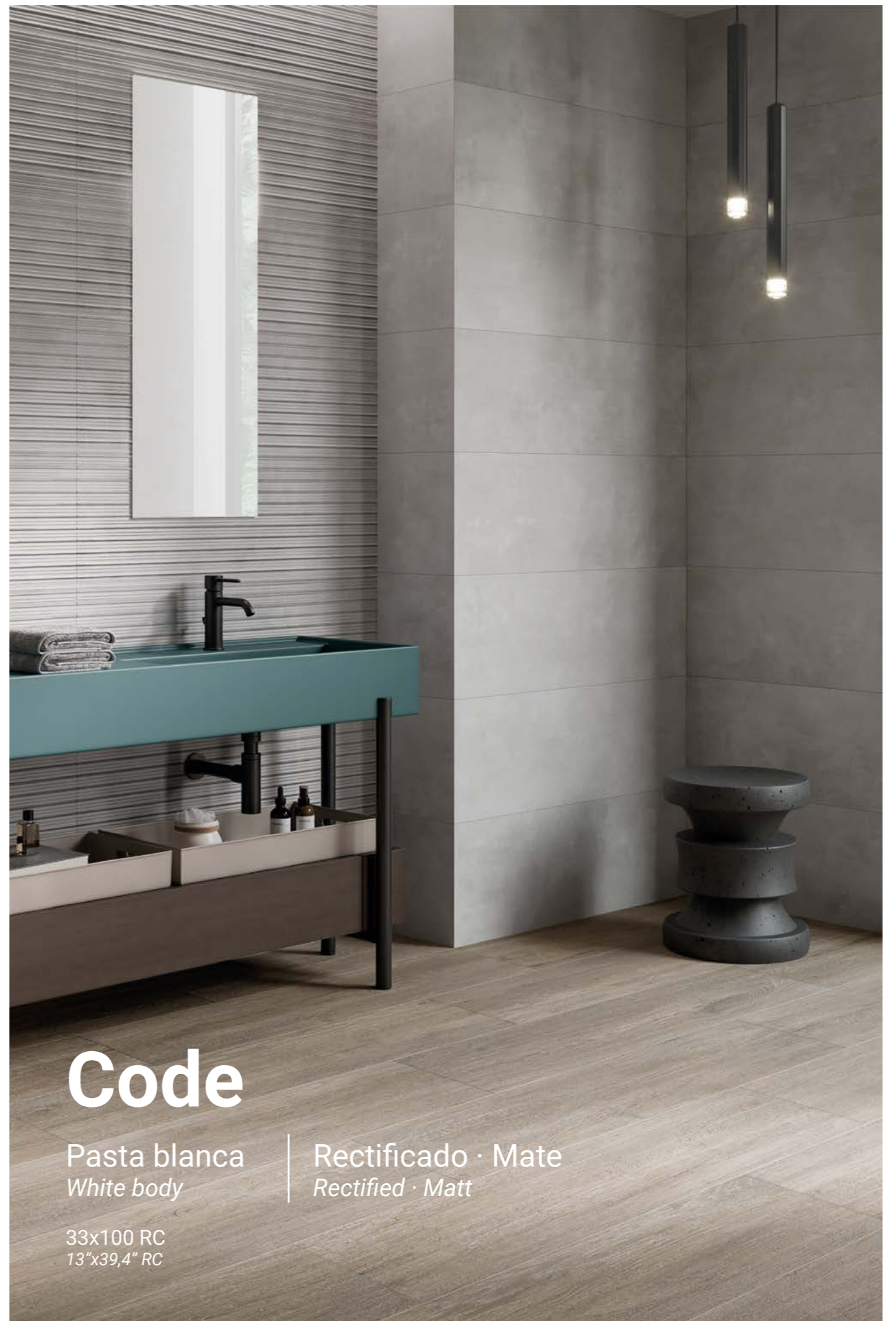

# Code

Pasta blanca  
*White body*

Rectificado · Mate  
*Rectified · Matt*

33x100 RC  
*13"x39,4" RC*



CODE WHITE / B208  
CODE GREY / B208  
CODE BLACK / B208

EJEMPLO DE VARIEDAD GRÁFICA  
GRAPHIC VARIETY EXAMPLE

CODE GREY 33x100 RC  
CODE GREY 13"x39,4" RC

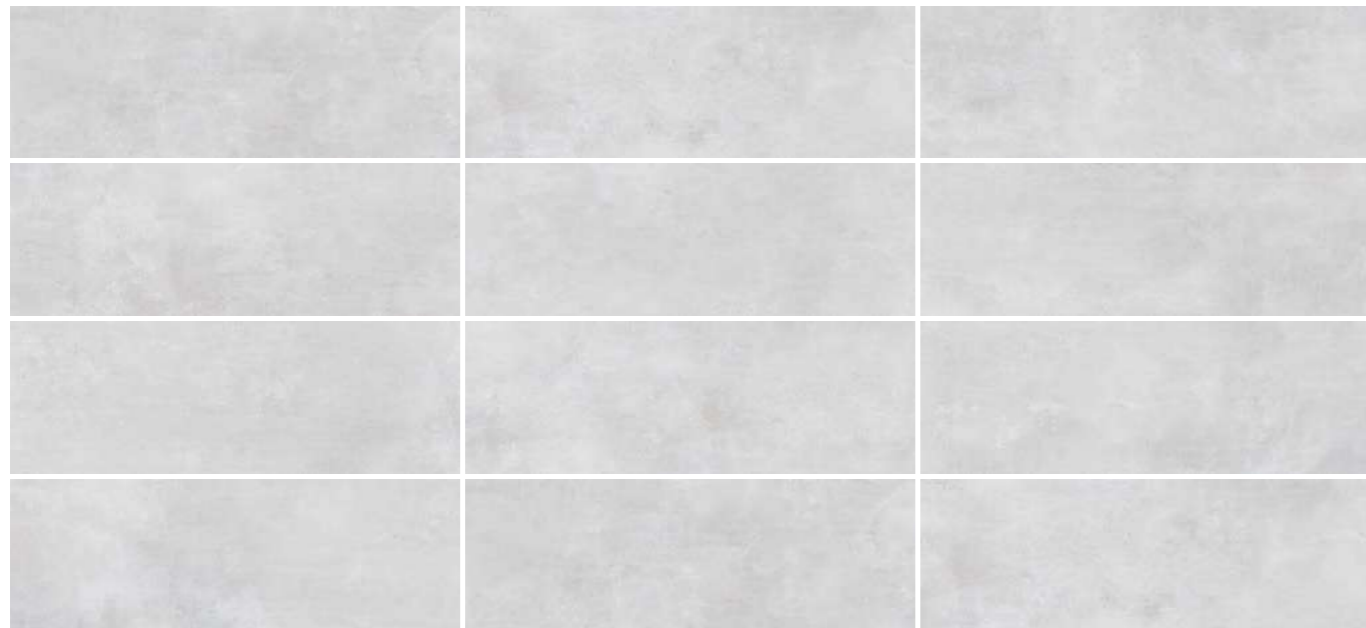

CODE REL GREY  
33x100 RC / B230



CODE REL BLACK  
33x100 RC / B230



CODE BLACK 33x100 RC / CODE REL BLACK 33x100 RC / FORMENTERA ROBLE 19,4x120 RC



pearl

grey

bone

oxide

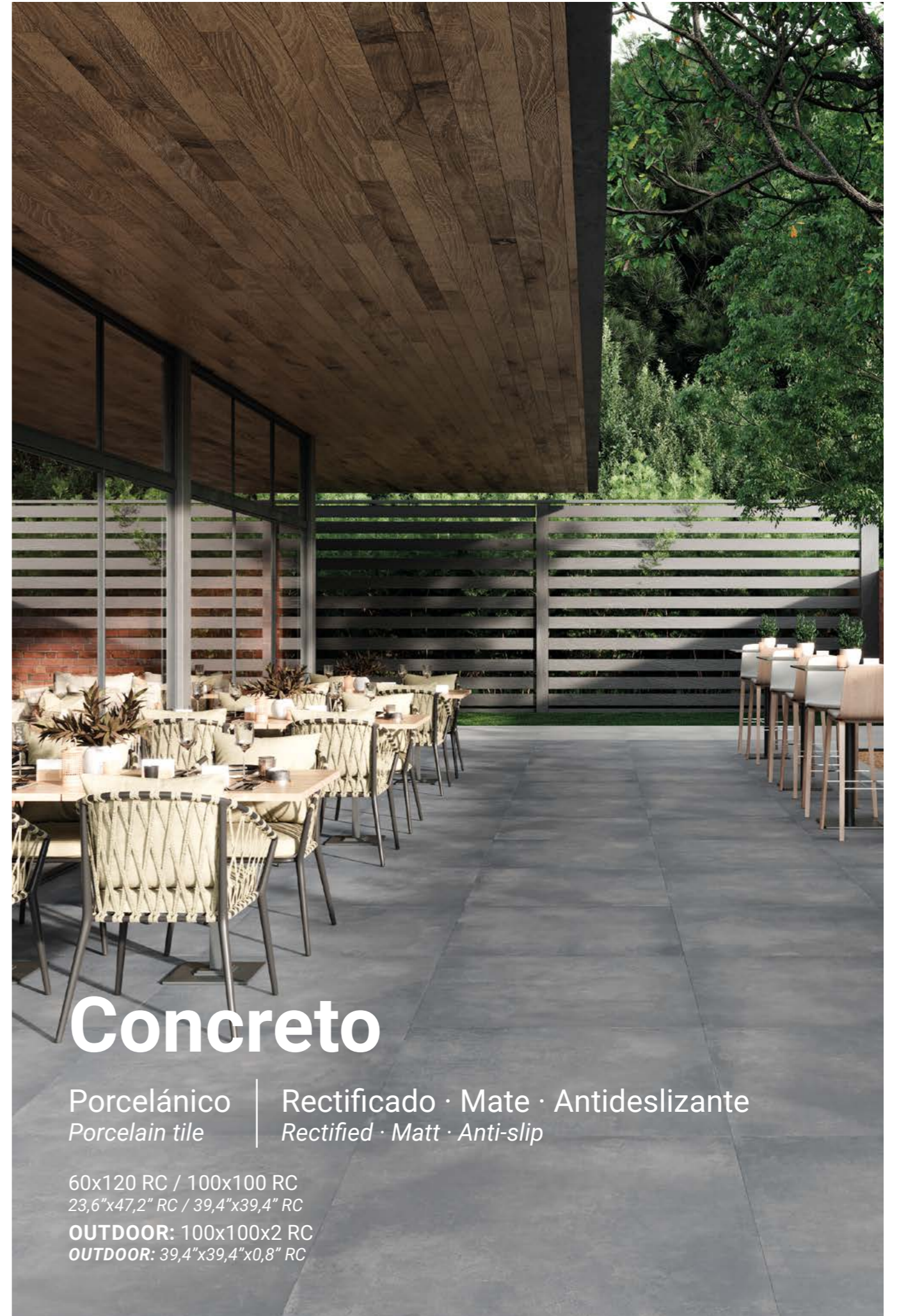

# Concreto

Porcelánico  
Porcelain tile

Rectificado · Mate · Antideslizante  
Rectified · Matt · Anti-slip

60x120 RC / 100x100 RC  
23,6"x47,2" RC / 39,4"x39,4" RC

**OUTDOOR:** 100x100x2 RC  
**OUTDOOR:** 39,4"x39,4"x0,8" RC

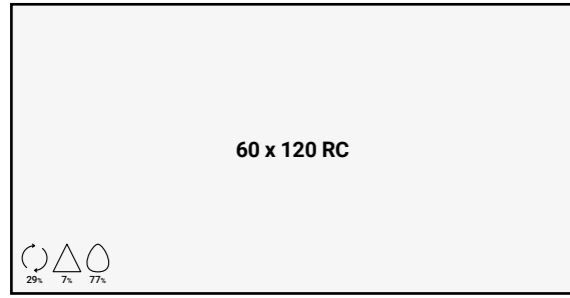

CONCRETO PEARL / B310  
CONCRETO PEARL CTE3/R11/C / B310  
CONCRETO GREY / B310  
CONCRETO GREY CTE3/R11/C / B310  
CONCRETO BONE / B310  
CONCRETO BONE CTE3/R11/C / B310  
CONCRETO OXIDE / B310  
CONCRETO OXIDE CTE3/R11/C / B310

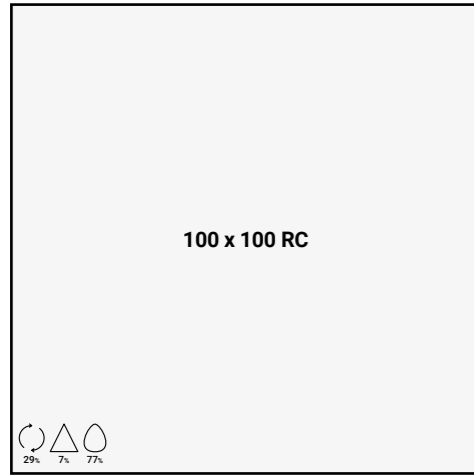

CONCRETO PEARL / B310  
CONCRETO GREY / B310  
CONCRETO BONE / B310  
CONCRETO OXIDE / B310

CONCRETO PEARL 20 CTE3/R11/C / B600  
CONCRETO GREY 20 CTE3/R11/C / B600  
CONCRETO BONE 20 CTE3/R11/C / B600  
CONCRETO OXIDE 20 CTE3/R11/C / B600

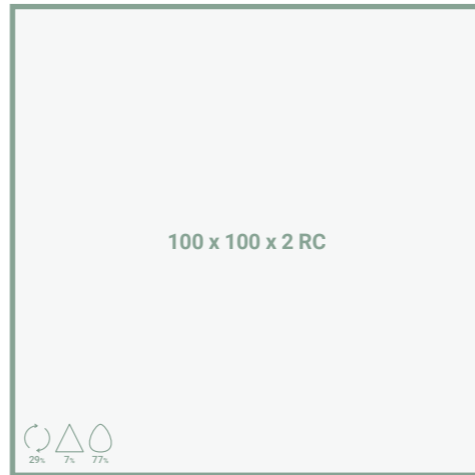

100 x 100 x 2 RC

EJEMPLO DE VARIEDAD GRÁFICA  
GRAPHIC VARIETY EXAMPLE

CONCRETO GREY 60x120 RC  
CONCRETO GREY 23,6"x47,2" RC

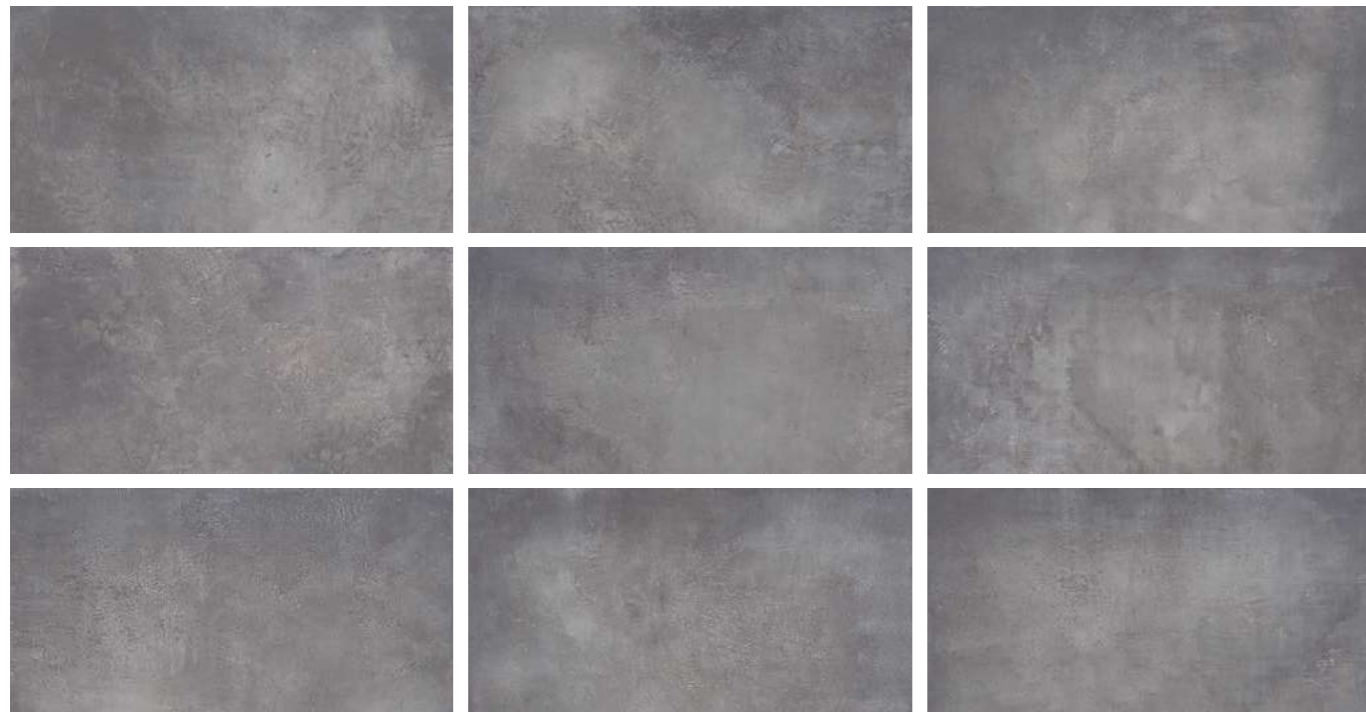

CONCRETO DEC PEARL  
60x120 RC / B310



CONCRETO DEC GREY  
60x120 RC / CB310



CONCRETO DEC BONE  
60x120 RC / CB310



CONCRETO DEC OXIDE  
60x120 RC / CB310



CONCRETO DEC PEARL 60x120 RC / CONCRETO OXIDE 100x100 RC



white



grey



grafito



# Contract

Porcelánico  
Porcelain tile

Rectificado · Mate  
Rectified · Matt

60x120 RC  
23,6"x47,2" RC

**OUTDOOR:** 60x120x2 RC  
**OUTDOOR:** 23,6"x47,2"x0,8" RC



OUTDOOR 20

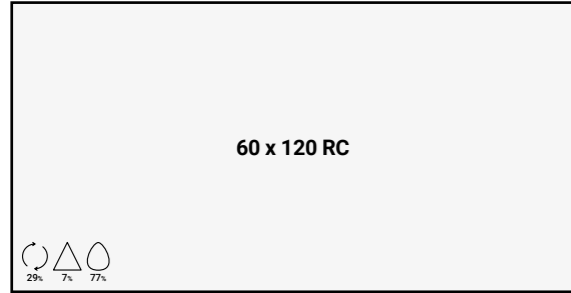

60 x 120 RC

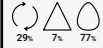

CONTRACT WHITE / B310  
CONTRACT GRAFITO / B310  
CONTRACT GREY / B310



60 x 120 x 2 RC



CONTRACT 20 WHITE CTE3/R11/C / B600  
CONTRACT 20 GRAFITO CTE3/R11/C / B600  
CONTRACT 20 GREY CTE3/R11/C / B600

EJEMPLO DE VARIEDAD GRÁFICA  
GRAPHIC VARIETY EXAMPLE

CONTRACT GREY 60x120 RC  
CONTRACT GREY 23,6"x47,2" RC



MS CONTRACT WHITE  
30x30 / C83



MS CONTRACT GRAFITO  
30x30 / C83



MS CONTRACT GRAFITO  
30x30 / C83



CONTRACT 20 GREY 60x120 RC / CONTRACT 20 GRAFITO 60 x120 RC

white

grey

calcite

Exa

Porcelánico | Rectificado · Mate  
Porcelain tile | Rectified · Matt

60x60 RC  
23,6"x23,6" RC

PASTA BLANCA: 33x100 RC  
WHITE BODY: 13"x39,4" RC

33 x 100 RC



PASTA BLANCA  
WHITE BODY

EXA WHITE / B208  
EXA GREY / B208  
EXA CALCITE / B208

60 x 60 RC

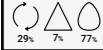

EXA WHITE / B226  
EXA GREY / B226  
EXA CALCITE / B226

EJEMPLO DE VARIEDAD GRÁFICA  
GRAPHIC VARIETY EXAMPLE

EXA GREY 60x60 RC  
EXA GREY 23,6"x23,6" RC

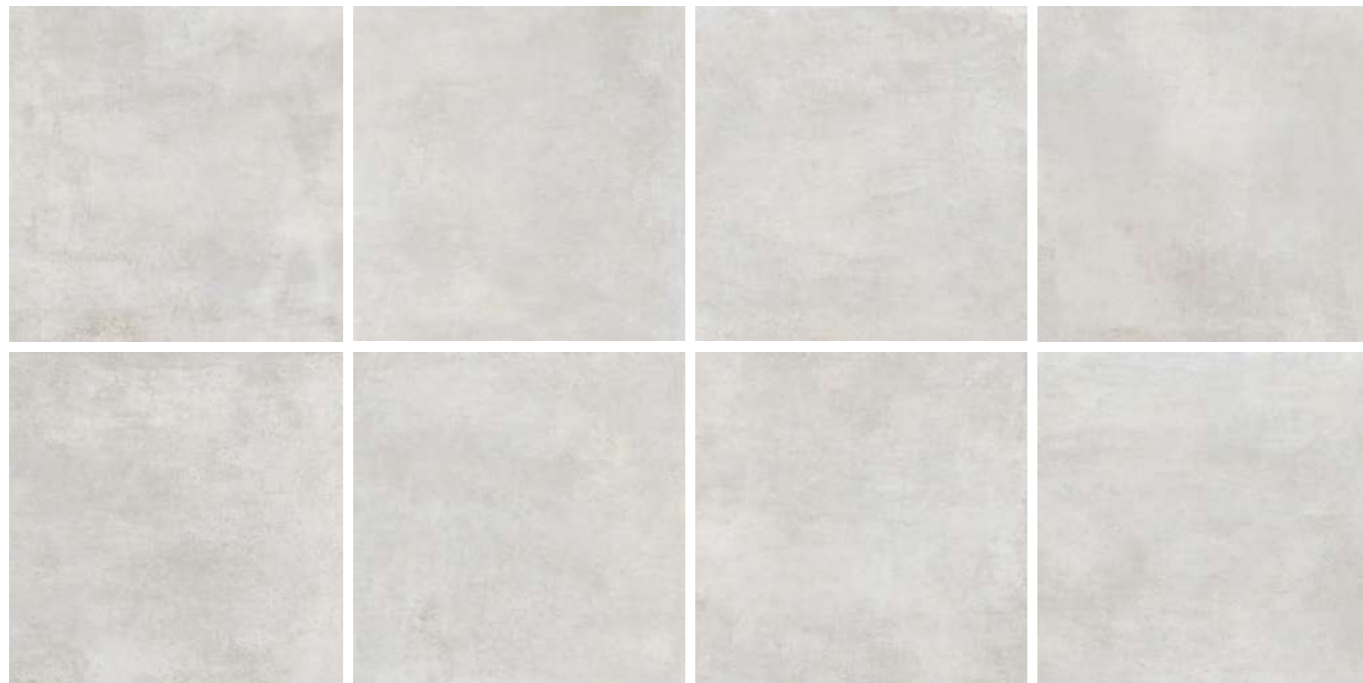

EXA-DEC MAGIS WHITE A  
33x100 RC / C395



EXA-DEC MAGIS WHITE B  
33x100 RC / C395



EXA-DEC MAGIS GREY A  
33x100 RC / C395



EXA-DEC MAGIS GREY B  
33x100 RC / C395



EXA-DEC MAGIS CALCITE A  
33x100 RC / C395



EXA-DEC MAGIS CALCITE B  
33x100 RC / C395



EXA-DEC COLD  
33x100 RC / B230



EXA-DEC WARM  
33x100 RC / B230



EXA-DEC VOLUTE WHITE  
33x100 RC / C395



EXA-REL WHITE  
33x100 RC / B230



EXA-DEC VOLUTE GREY  
33x100 RC / C395



EXA-REL GREY  
33x100 RC / B230



EXA-DEC VOLUTE CALCITE  
33x100 RC / C395



EXA-REL CALCITE  
33x100 RC / B230



white

grey

calcite

taupe



# Hackney

Porcelánico | Rectificado · Mate  
 Porcelain tile | Rectified · Matt

47,2x47,2  
 18,9"x18,9"

**PASTA BLANCA:** 25x75  
**WHITE BODY:** 9,8"x29,5"



HACKNEY WHITE / B149  
HACKNEY GREY / B149  
HACKNEY CALCITE / B149  
HACKNEY TAUPE / B149

PASTA BLANCA  
WHITE BODY COLOR

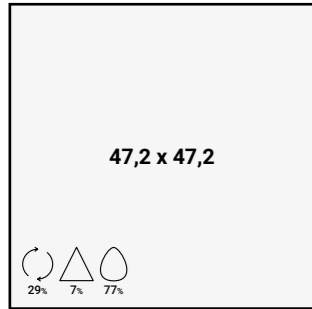

HACKNEY WHITE / B186  
HACKNEY GREY / B186  
HACKNEY CALCITE / B186  
HACKNEY TAUPE / B186

EJEMPLO DE VARIEDAD GRÁFICA  
GRAPHIC VARIETY EXAMPLE

HACKNEY GREY 47,2x47,2 RC  
HACKNEY GREY 18,6"x18,6" RC

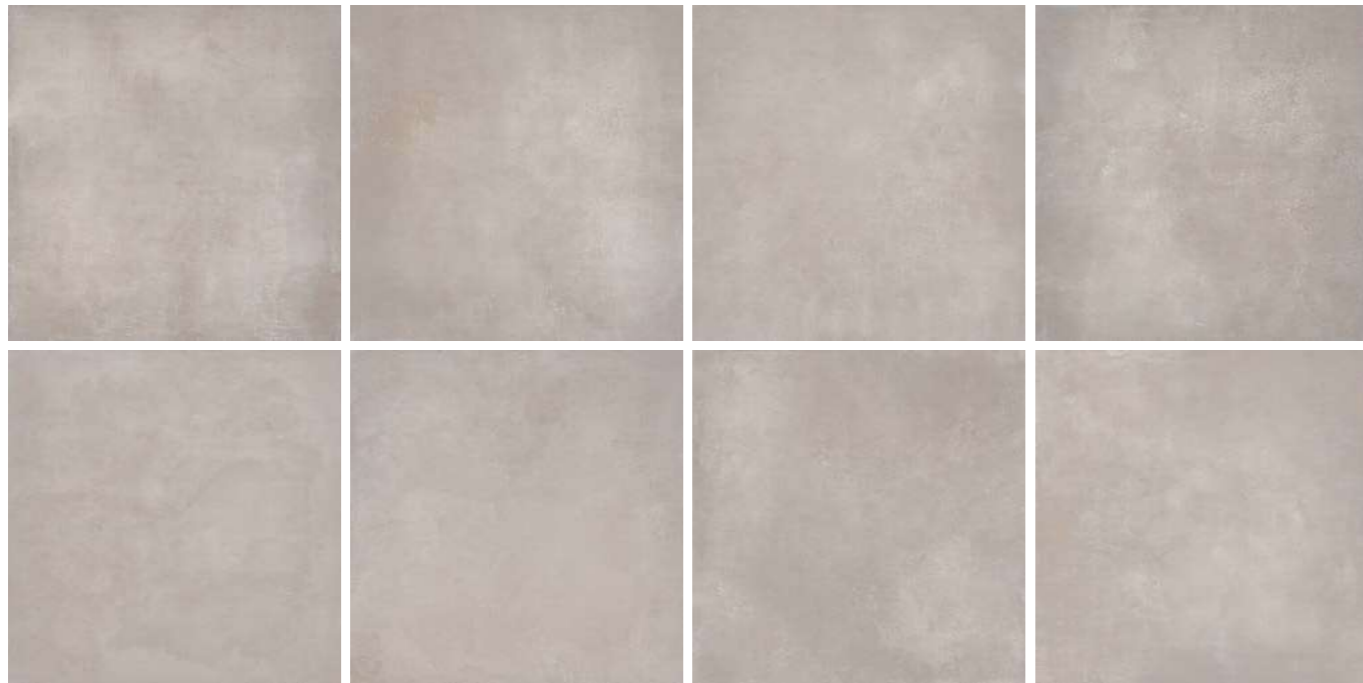

HACKNEY-REL WHITE  
25x75 / B166



HACKNEY-REL CALCITE  
25x75 / B166



HACKNEY-REL GREY  
25x75 / B166



HACKNEY-REL TAUPE  
25x75 / B166



HACKNEY-DEC COLD  
25x75 / B166



HACKNEY-DEC WARM  
25x75 / B166



HACKNEY GREY 47,2x47,2 / HACKNEY GREY 25x75 / HACKNEY DEC COLD 25x75

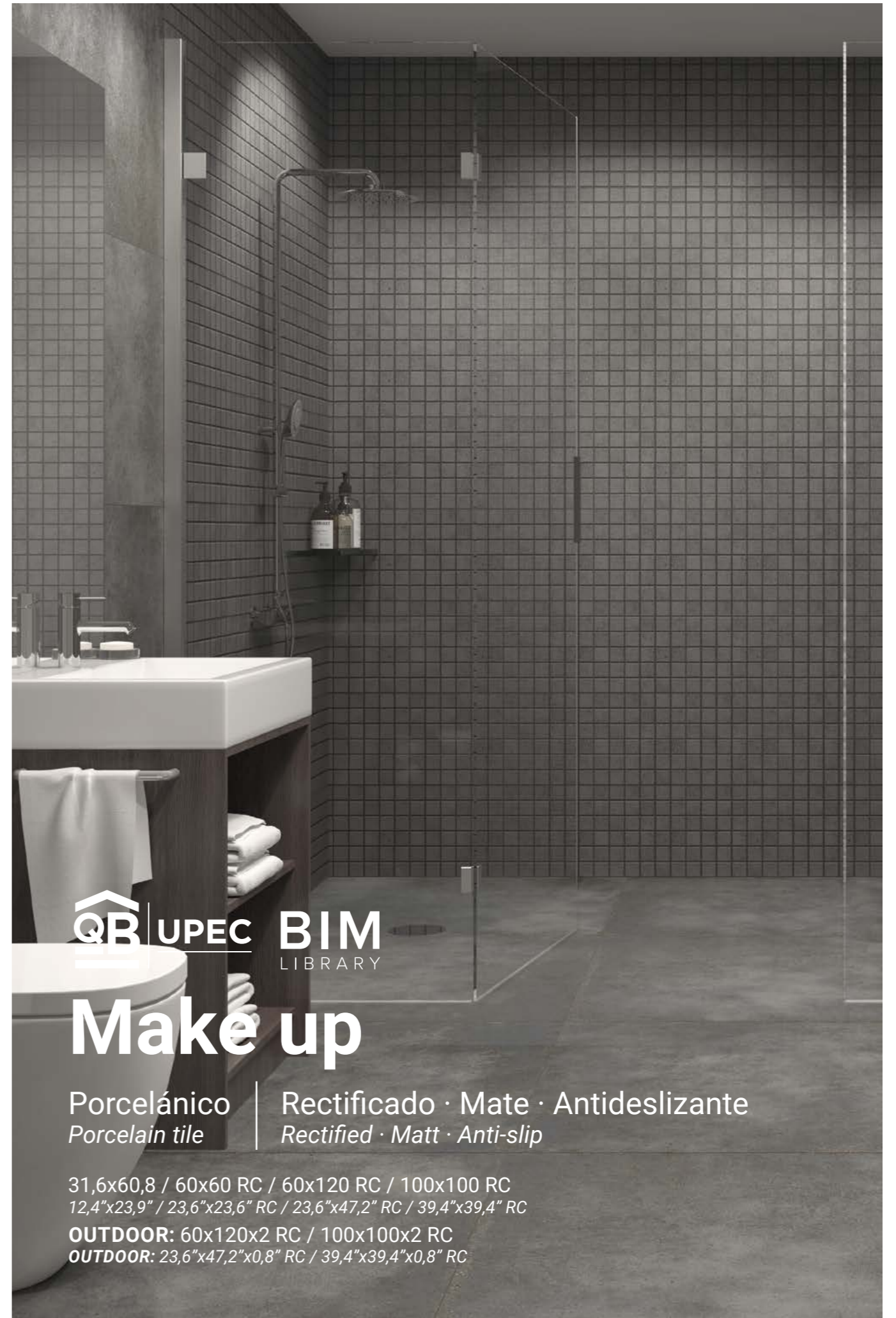

QB UPEC BIM  
LIBRARY

# Make up

Porcelánico  
*Porcelain tile*

Rectificado · Mate · Antideslizante  
*Rectified · Matt · Anti-slip*

31,6x60,8 / 60x60 RC / 60x120 RC / 100x100 RC  
12,4"x23,9" / 23,6"x23,6" RC / 23,6"x47,2" RC / 39,4"x39,4" RC

**OUTDOOR:** 60x120x2 RC / 100x100x2 RC  
**OUTDOOR:** 23,6"x47,2"x0,8" RC / 39,4"x39,4"x0,8" RC

**31,6 x 60,8**

MAKE UP WHITE CTE1/R9 / B186  
 MAKE UP GREY CTE1/R9 / B186  
 MAKE UP DARK CTE1/R9 / B186  
 MAKE UP MINK CTE1/R9 / B186

**60 x 60 RC**

MAKE UP WHITE CTE1/R9 / B226  
 MAKE UP WHITE CTE3/R11/C / B226  
 MAKE UP GREY CTE1/R9 / B226  
 MAKE UP GREY CTE3/R11/C / B226  
 MAKE UP DARK CTE1/R9 / B226  
 MAKE UP DARK CTE3/R11/C / B226  
 MAKE UP MINK CTE1/R9 / B226  
 MAKE UP MINK CTE3/R11/C / B226

**60 x 120 RC**

MAKE UP WHITE CTE1/R9 / B310  
 MAKE UP GREY CTE1/R9 / B310  
 MAKE UP DARK CTE1/R9 / B310  
 MAKE UP MINK CTE1/R9 / B310

**60 x 120 x 2 RC**

MAKE UP 20 WHITE CTE3/R11/C / B600  
 MAKE UP 20 GREY CTE3/R11/C / B600  
 MAKE UP 20 DARK CTE3/R11/C / B600  
 MAKE UP 20 MINK CTE3/R11/C / B600

**100 x 100 RC**

MAKE UP WHITE CTE1/R9 / B310  
 MAKE UP WHITE CTE3/R11/C / B310  
 MAKE UP GREY CTE1/R9 / B310  
 MAKE UP GREY CTE3/R11/C / B310  
 MAKE UP DARK CTE1/R9 / B310  
 MAKE UP MINK CTE1/R9 / B310  
 MAKE UP MINK CTE3/R11/C / B310

**100 x 100 x 2 RC**

MAKE UP 20 WHITE CTE3/R11/C / B600  
 MAKE UP 20 GREY CTE3/R11/C / B600  
 MAKE UP 20 DARK CTE3/R11/C / B600  
 MAKE UP 20 MINK CTE3/R11/C / B600

EJEMPLO DE VARIEDAD GRÁFICA  
 GRAPHIC VARIETY EXAMPLE

MAKE UP GREY 100x100 RC  
 MAKE UP GREY 39,4"x39,4" RC



MS MAKE UP WHITE  
30x30 / C75

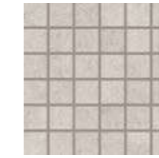

MS MAKE UP GREY  
30x30 / C75

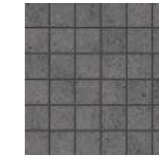

MS MAKE UP DARK  
30x30 / C75



MS MAKE UP MINK  
30x30 / C75



MAKE UP HIDRA WARM / 60x60 RC / B226  
 MAKE UP HIDRA 20 WARM / 60x60 RC / B410



MAKE UP HIDRA COLD / 60x60 RC / B226  
 MAKE UP HIDRA 20 COLD / 60x60 RC / B410



MAKE UP 20 GREY 60x60 RC / MAKE UP HIDRA COLD 60x60 RC

white



graphite



nude



# Manhattan

Porcelánico  
*Porcelain tile*

Rectificado · Mate  
*Rectified · Matt*

60x60 RC  
23,6"x23,6" RC

**PASTA BLANCA:** 33x100 RC

**WHITE BODY:** 13"x39,4" RC



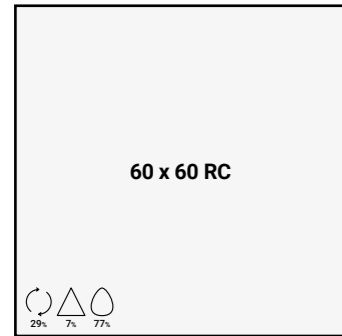

EJEMPLO DE VARIEDAD GRÁFICA  
GRAPHIC VARIETY EXAMPLE

MANHATTAN GRAPHITE 60x60 RC  
MANHATTAN GRAPHITE 23,6"x23,6" RC

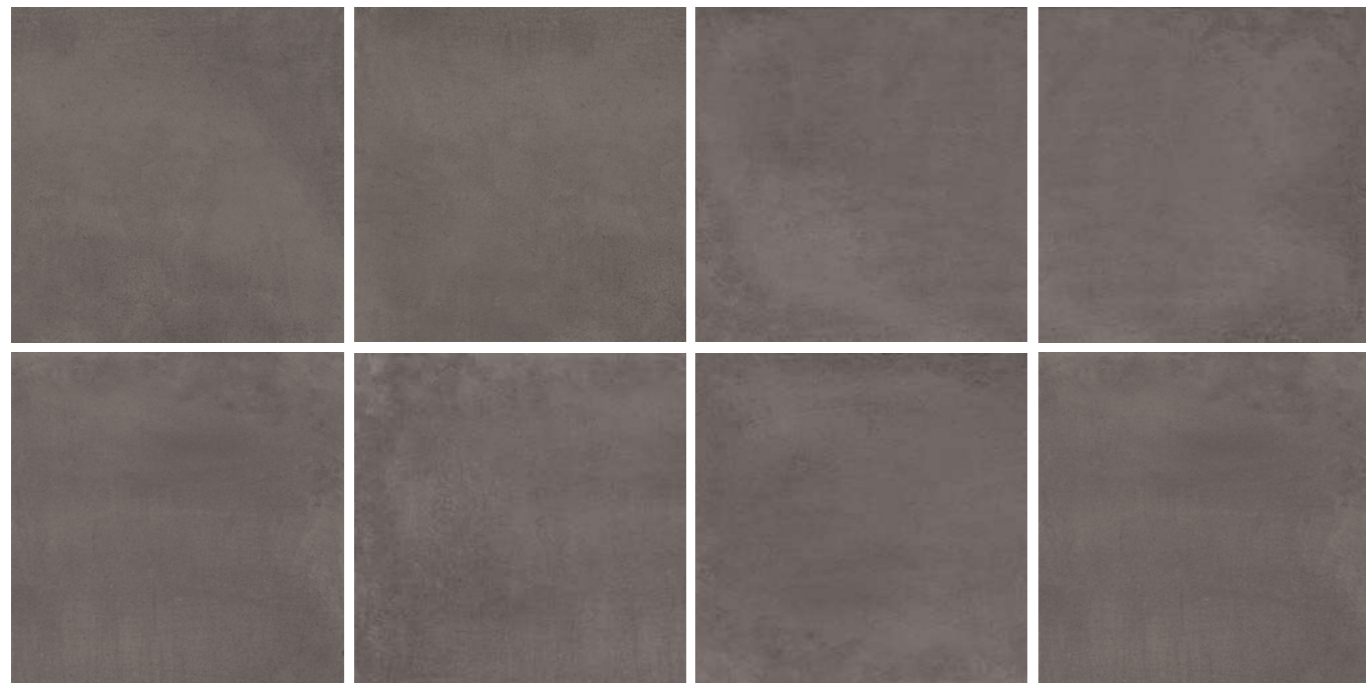

MANHATTAN DEC WHITE  
33x100 RC / B230



MANHATTAN REL WHITE  
33x100 RC / B230



MANHATTAN DEC GRAPHITE  
33x100 RC / B230



MANHATTAN REL GRAPHITE  
33x100 RC / B230



MANHATTAN DEC NUDE  
33x100 RC / B230



MANHATTAN REL NUDE  
33x100 RC / B230



MANHATTAN NUDE 33x100 RC / MANHATTAN REL NUDE 33x100 RC / MANHATTAN GRAPHITE 60x60 RC



blanco



# Menorca

Pasta blanca  
*White body*

Rectificado · Mate  
*Rectified · Matt*

**PASTA BLANCA:** 33x100 RC  
**WHITE BODY:** 13"x39,4" RC



MENORCA BLANCO / B208

EJEMPLO DE VARIEDAD GRÁFICA  
GRAPHIC VARIETY EXAMPLE

MENORCA BLANCO 33x100 RC  
MENORCA BLANCO 13"x39,4" RC

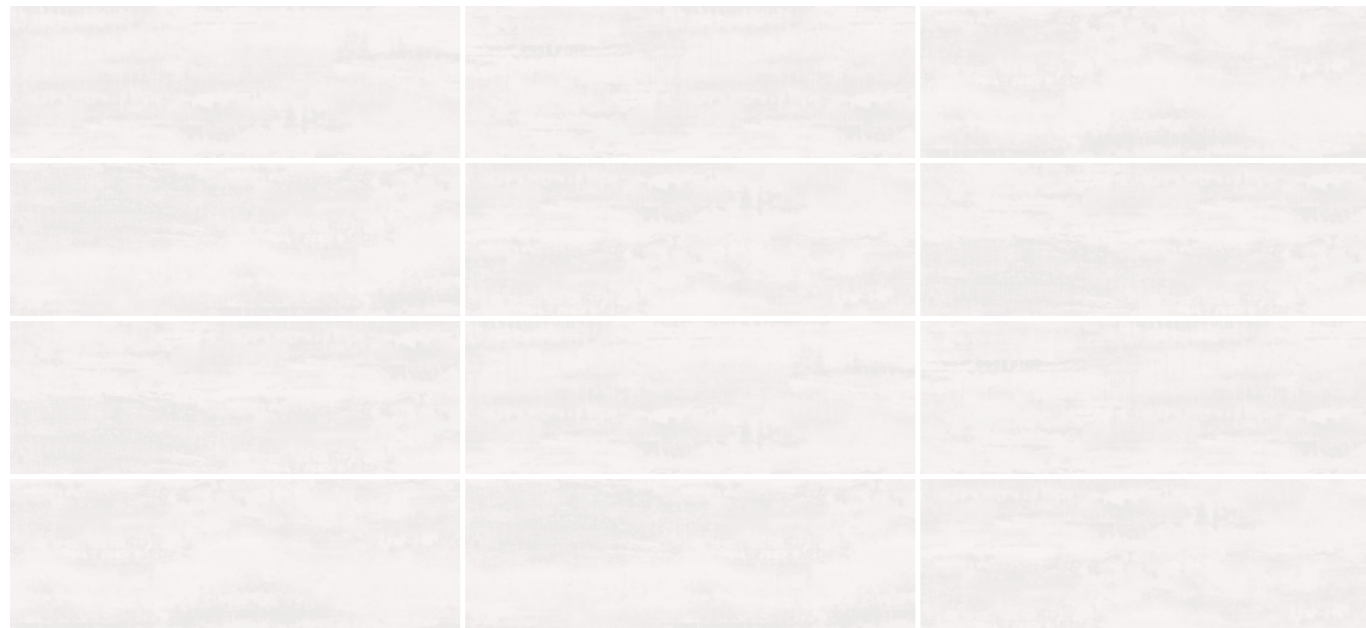

MENORCA REL BLANCO  
33x100 RC / B230



MENORCA REL BLANCO 33x100 RC

white

grey

anthracite

ivory

oxide



# Metalart

Porcelánico	Mate
Porcelain tile	Matt

47,2x47,2  
18,6"x18,6"

REVESTIMIENTO: 20x60  
WALL TILE: 7,9"x23,6"

FORMATOS DISPONIBLES  
AVAILABLE SIZES



METALART WHITE / B115  
METALART GREY / B115  
METALART ANTHRACITE / B115  
METALART IVORY / B115  
METALART OXIDE / B115

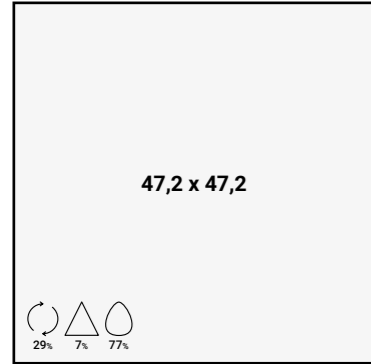

METALART WHITE / B186  
METALART GREY / B186  
METALART ANTHRACITE / B186  
METALART IVORY / B186  
METALART OXIDE / B186

EJEMPLO DE VARIEDAD GRÁFICA  
GRAPHIC VARIETY EXAMPLE

METALART ANTHRACITE 20X60  
METALART ANTHRACITE 7,9"x23,6"

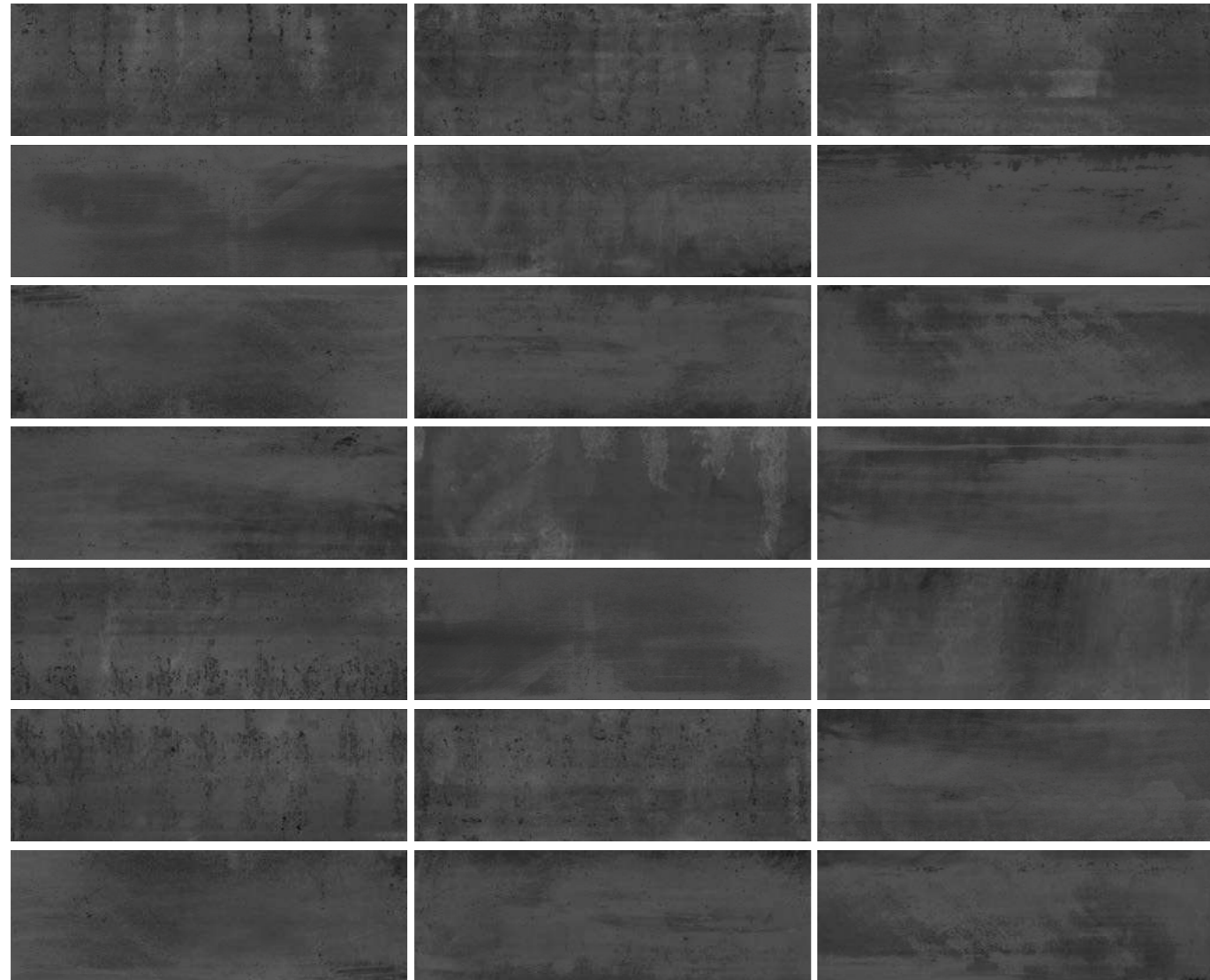

COMPLEMENTOS  
ACCESSORIES



MS METALART WHITE  
30x30 / C77



MS METALART GREY  
30x30 / C77



MS METALART ANTHRACITE  
30x30 / C77



MS METALART IVORY  
30x30 / C77



MS METALART OXIDE  
30x30 / C77



METALART-REL WHITE  
20x60 / B138



METALART-REL GREY  
20x60 / B138



METALART-REL ANTHRACITE  
20x60 / B138



METALART DEC-2 WHITE  
20x60 / B138



METALART DEC-2 GREY  
20x60 / B138



METALART DEC-2 ANTHRACITE  
20x60 / B138



METALART-REL IVORY  
20x60 / B138



METALART-REL OXIDE  
20x60 / B138



METALART DEC-2 IVORY  
20x60 / B138



METALART DEC-2 OXIDE  
20x60 / B138



METALART GREY 20x60 / METALART REL GREY 20x60 / METALART ANTHRACITE 47,2x47,2 / METALART REL ANTHRACITE 20x60



white

grey

mink

noce

anthracite



**QB** UPEC **QB** UPEC.F+

# Mustang

Porcelánico  
Porcelain tile

Rectificado · Mate · Antideslizante  
Rectified · Matt · Anti-slip

60x60 / 60x60 RC / 75x75 RC  
23,6"x23,6" / 23,6"x23,6" RC / 29,5"x29,5" RC  
**OUTDOOR:** 75x75x2 RC / 60x60x2 RC  
**OUTDOOR:** 29,5"x29,5"x0,8" RC / 23,6"x23,6"x0,8" RC

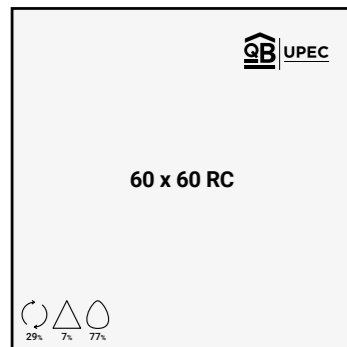

MUSTANG WHITE / B226  
MUSTANG GREY / B226  
MUSTANG ANTHRACITE / B226  
MUSTANG MINK / B226  
MUSTANG NOCE / B226

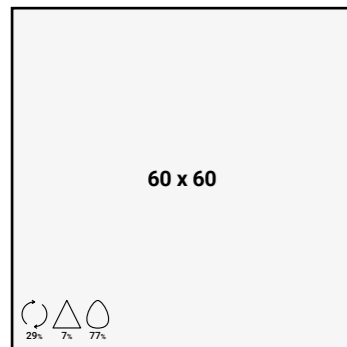

MUSTANG WHITE CTE3/R11/C / B208  
MUSTANG GREY CTE3/R11/C / B208  
MUSTANG MINK CTE3/R11/C / B208

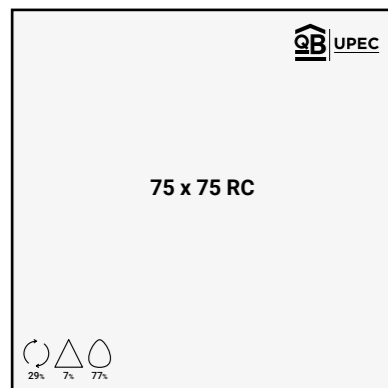

MUSTANG WHITE / B273  
MUSTANG GREY / B273  
MUSTANG ANTHRACITE / B273  
MUSTANG MINK / B273  
MUSTANG NOCE / B273



MUSTANG 20 WHITE CTE3/R11/C / B410  
MUSTANG 20 GREY CTE3/R11/C / B410  
MUSTANG 20 ANTHRACITE CTE3/R11/C / B410  
MUSTANG 20 MINK CTE3/R11/C / B410  
MUSTANG 20 NOCE CTE3/R11/C / B410



MUSTANG 20 WHITE CTE3/R11/C / B524  
MUSTANG 20 GREY CTE3/R11/C / B524  
MUSTANG 20 ANTHRACITE CTE3/R11/C / B524  
MUSTANG 20 MINK CTE3/R11/C / B524  
MUSTANG 20 NOCE CTE3/R11/C / B524

EJEMPLO DE VARIEDAD GRÁFICA  
GRAPHIC VARIETY EXAMPLE

MUSTANG GREY 60x60 RC  
MUSTANG GREY 23,6"x23,6"

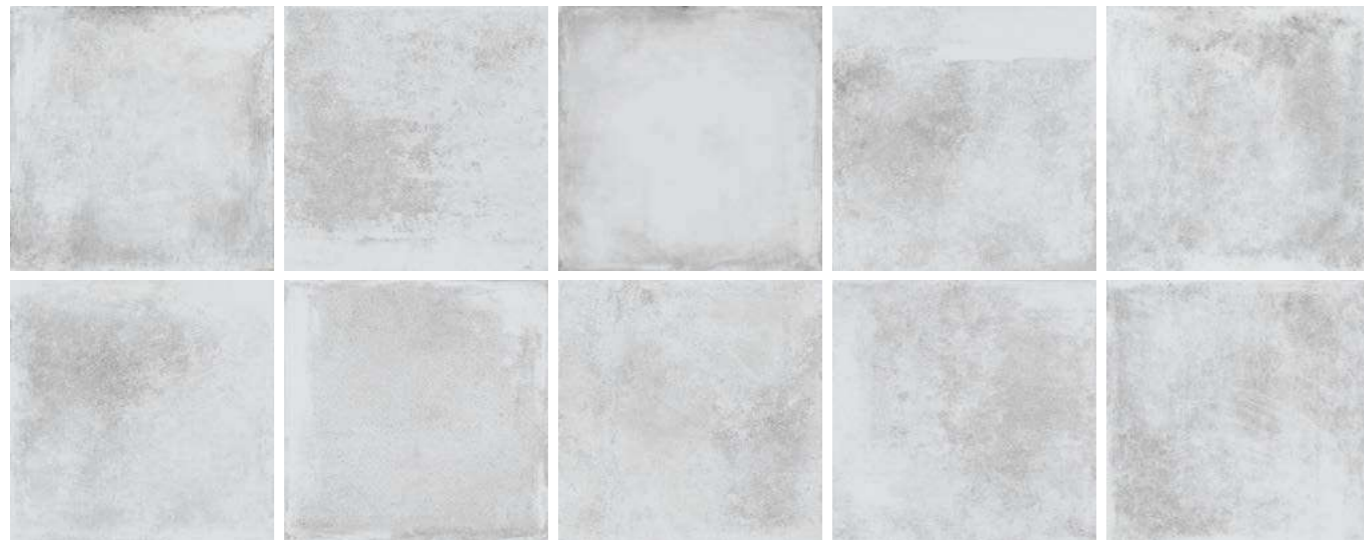

MS MUSTANG WHITE  
30x30 / C77



MS MUSTANG GREY  
30x30 / C77



MS MUSTANG ANTHRACITE  
30x30 / C77



MS MUSTANG MINK  
30x30 / C77



MS MUSTANG NOCE  
30x30 / C77



MUSTANG 20 GREY 75x75 RC / MUSTANG GREY 75x75 RC



BIM  
LIBRARY

# Nomade

Porcelánico  
Porcelain tile

Rectificado · Mate · Antideslizante · Lappato  
Rectified · Matt · Anti-slip · Lappato

60x60 RC / 60x120 RC / 100x100 RC  
23,6" x 23,6" RC / 23,6" x 47,2" RC / 39,4" x 39,4" RC

**OUTDOOR:** 60x60x2 RC / 60x120x2 RC / 100x100x2 RC  
**OUTDOOR:** 23,6" x 23,2" x 0,8" RC / 23,6" x 47,2" x 0,8" RC / 39,4" x 39,4" x 0,8" RC

**VIKER:** 40x120 RC  
**VIKER:** 15,7" x 47,2" RC

**PASTA BLANCA:** 33x100 RC  
**WHITE BODY:** 13" x 39,4" RC





NOMADE WHITE / B208  
NOMADE GREY / B208  
NOMADE BONE / B208  
NOMADE TAUPE / B208



NOMADE 7 WHITE / B288  
NOMADE 7 GREY / B288  
NOMADE 7 BONE / B288  
NOMADE 7 TAUPE / B288

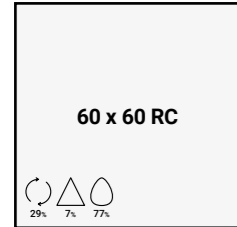

NOMADE WHITE CTE2/R10 / B226  
NOMADE WHITE CTE3/R11/C / B226  
NOMADE GREY CTE2/R10 / B226  
NOMADE GREY CTE3/R11/C / B226  
NOMADE BONE CTE2/R10 / B226  
NOMADE BONE CTE3/R11/C / B226  
NOMADE TAUPE CTE2/R10 / B226  
NOMADE TAUPE CTE3/R11/C / B226



NOMADE WHITE CTE2/R10 / B310  
NOMADE WHITE LAP / B430  
NOMADE GREY CTE2/R10 / B310  
NOMADE GREY LAP / B430  
NOMADE BONE CTE2/R10 / B310  
NOMADE BONE LAP / B430  
NOMADE TAUPE CTE2/R10 / B310  
NOMADE TAUPE LAP / B430

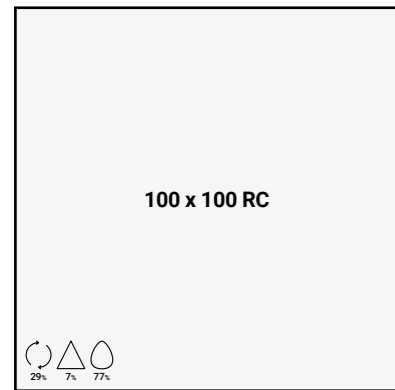

NOMADE WHITE CTE2/R10 / B310  
NOMADE WHITE LAP / B430  
NOMADE GREY CTE2/R10 / B310  
NOMADE GREY LAP / B430  
NOMADE BONE CTE2/R10 / B310  
NOMADE BONE LAP / B430  
NOMADE TAUPE CTE2/R10 / B310  
NOMADE BONE LAP / B430

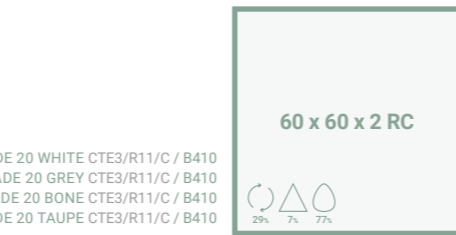

NOMADE 20 WHITE CTE3/R11/C / B410  
NOMADE 20 GREY CTE3/R11/C / B410  
NOMADE 20 BONE CTE3/R11/C / B410  
NOMADE 20 TAUPE CTE3/R11/C / B410

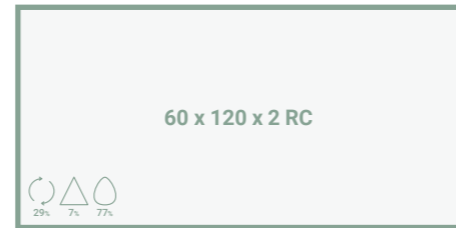

NOMADE 20 WHITE CTE3/R11/C / B600  
NOMADE 20 GREY CTE3/R11/C / B600  
NOMADE 20 BONE CTE3/R11/C / B600  
NOMADE 20 TAUPE CTE3/R11/C / B600



NOMADE 20 WHITE CTE3/R11/C / B600  
NOMADE 20 GREY CTE3/R11/C / B600  
NOMADE 20 BONE CTE3/R11/C / B600  
NOMADE 20 TAUPE CTE3/R11/C / B600

EJEMPLO DE VARIEDAD GRÁFICA  
GRAPHIC VARIETY EXAMPLE

NOMADE 7 GREY 40x120 RC  
NOMADE 7 GREY 15,7"x47,2" RC



NOMADE 7 REL WHITE / 40x120 RC / B310  
NOMADE REL WHITE / 33x100 RC / B230



NOMADE 7 REL GREY / 40x120 RC / B310  
NOMADE REL GREY / 33x100 RC / B230



NOMADE 7 REL BONE / 40x120 RC / B310  
NOMADE REL BONE / 33x100 RC / B230



NOMADE 7 REL TAUPE / 40x120 RC / B310  
NOMADE REL TAUPE / 33x100 RC / B230



NOMADE 7 DEC COLD / 40x120 RC / B310



NOMADE 7 DEC WARM / 40x120 RC / B310



NOMADE REL WHITE 33x100 RC / NOMADE WHITE 33x100 RC / NOMADE WHITE 60x60 RC



pearl

grey

black

sand

brown



# Synergy

Porcelánico  
Porcelain tile

Rectificado · Mate  
Rectified · Matt

60x60  
23,6"x23,6"

**OUTDOOR:** 60x60x2 RC  
**OUTDOOR:** 23,6"x23,6"x0,8" RC

OUTDOOR 20

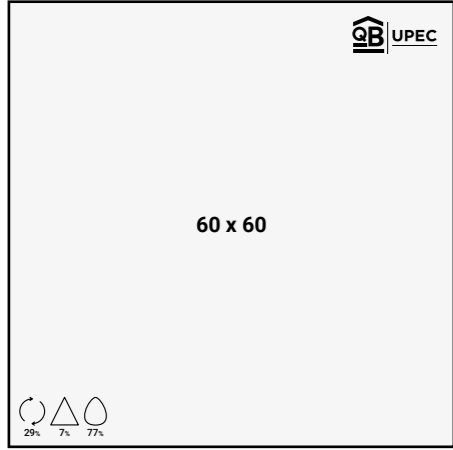

SYNERGY SAND / B208  
SYNERGY BROWN / B208  
SYNERGY PEARL / B208  
SYNERGY GREY / B208  
SYNERGY BLACK / B208



SYNERGY 20 SAND CTE3/R11/C / B410  
SYNERGY 20 BROWN CTE3/R11/C / B410  
SYNERGY 20 PEARL CTE3/R11/C / B410  
SYNERGY 20 GREY CTE3/R11/C / B410  
SYNERGY 20 BLACK CTE3/R11/C / B410

EJEMPLO DE VARIEDAD GRÁFICA  
GRAPHIC VARIETY EXAMPLE

SYNERGY 20 BROWN 60x60 RC  
SYNERGY 20 BROWN 23,6" x 23,6" RC

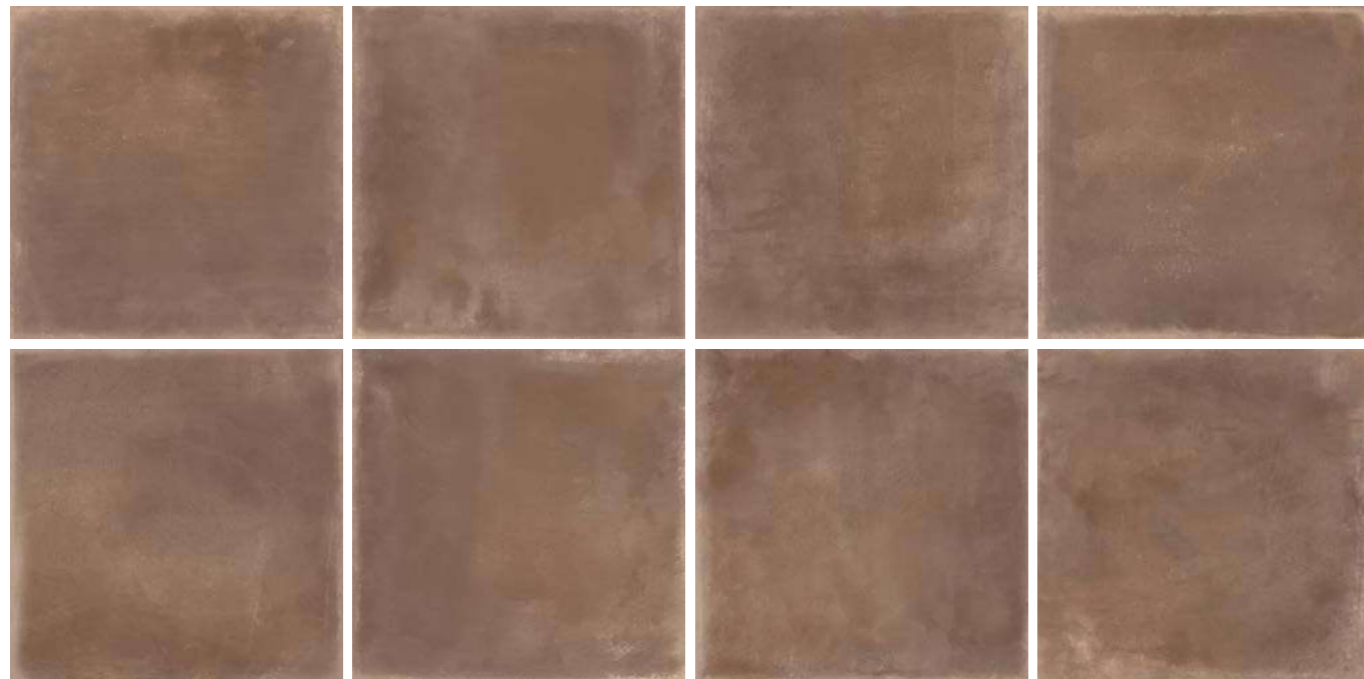

SYNERGY 20 BROWN 60x60 RC



white

grey

black

milk

taupe

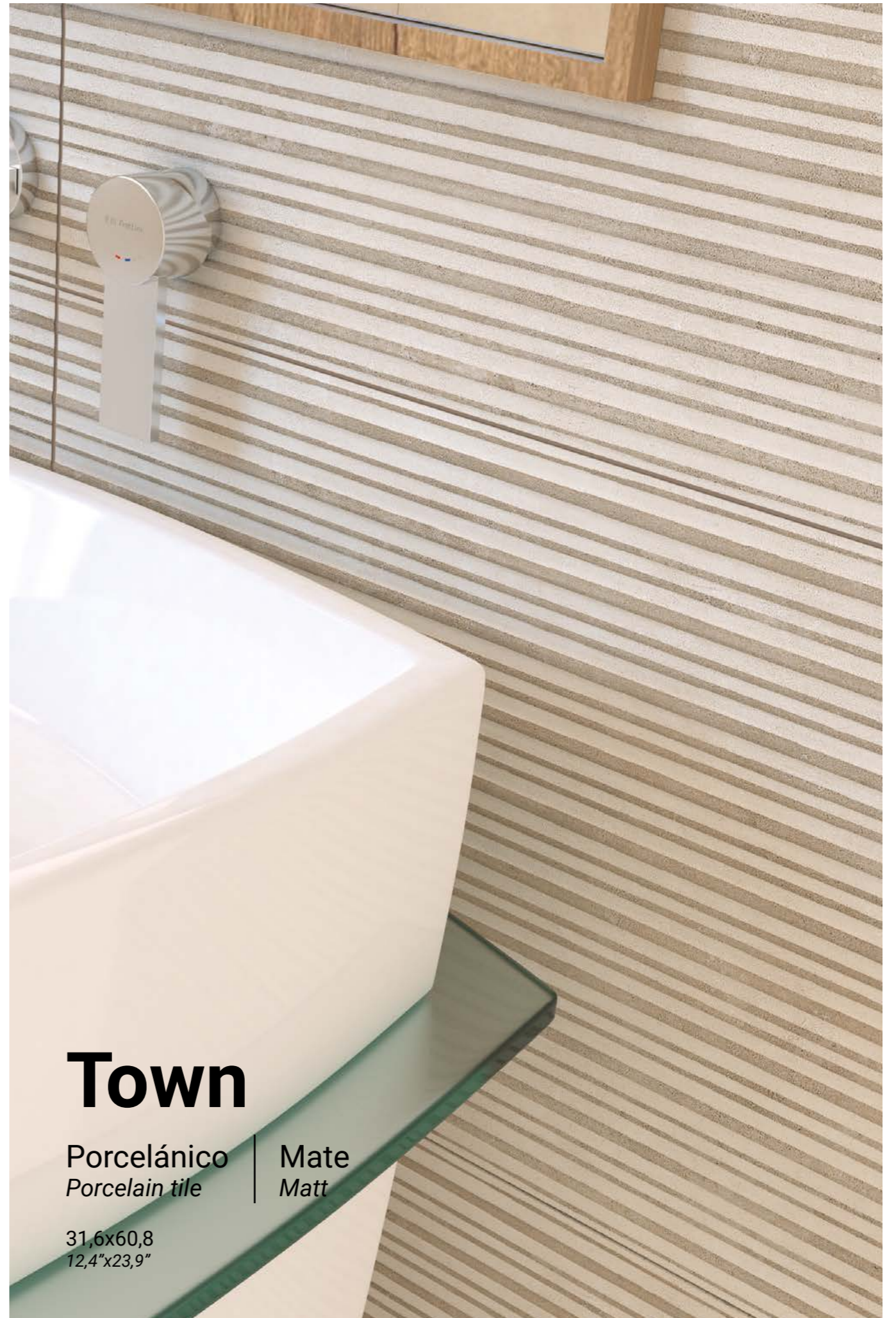

# Town

Porcelánico  
Porcelain tile

Mate  
Matt

31,6x60,8  
12,4"x23,9"

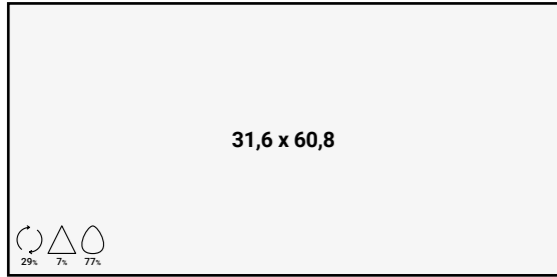

- TOWN WHITE CTE1 / B186
- TOWN WHITE CTE2 / B186
- TOWN WHITE CTE3/R11/C / B186
- TOWN GREY CTE1 / B186
- TOWN GREY CTE2 / B186
- TOWN GREY CTE3/R11/C / B186
- TOWN BLACK CTE1 / B186
- TOWN BLACK CTE2 / B186
- TOWN BLACK CTE3/R11/C / B186
- TOWN MINK CTE1 / B186
- TOWN MINK CTE2 / B186
- TOWN MINK CTE3/R11/C / B186
- TOWN TAUPE CTE1 / B186
- TOWN TAUPE CTE2 / B186
- TOWN TAUPE CTE3/R11/C / B186

EJEMPLO DE VARIEDAD GRÁFICA  
GRAPHIC VARIETY EXAMPLE

TOWN GREY 31,6x60,8  
TOWN GREY 12,4"x23,9"

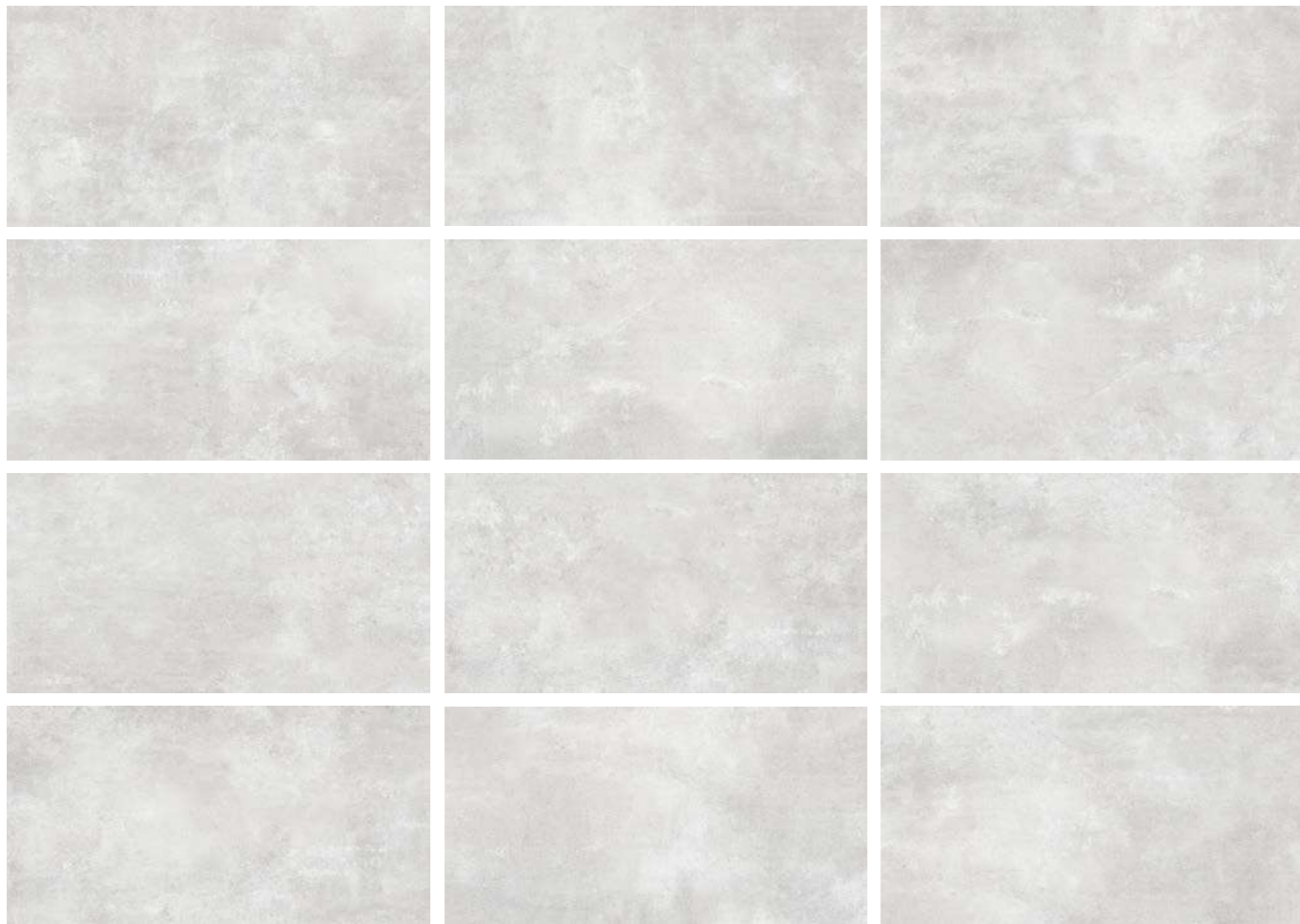

TOWN-REL GREY  
31,6x60,8 / B205

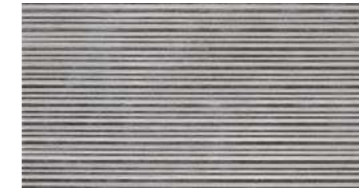

TOWN-REL BLACK  
31,6x60,8 / B205



TOWN-REL TAUPE  
31,6x60,8 / B205



TOWN GREY 31,6x60,8 / TOWN REL GREY 31,6x60,8



**PIEDRA**  
*STONE*



white



grey



black



cream

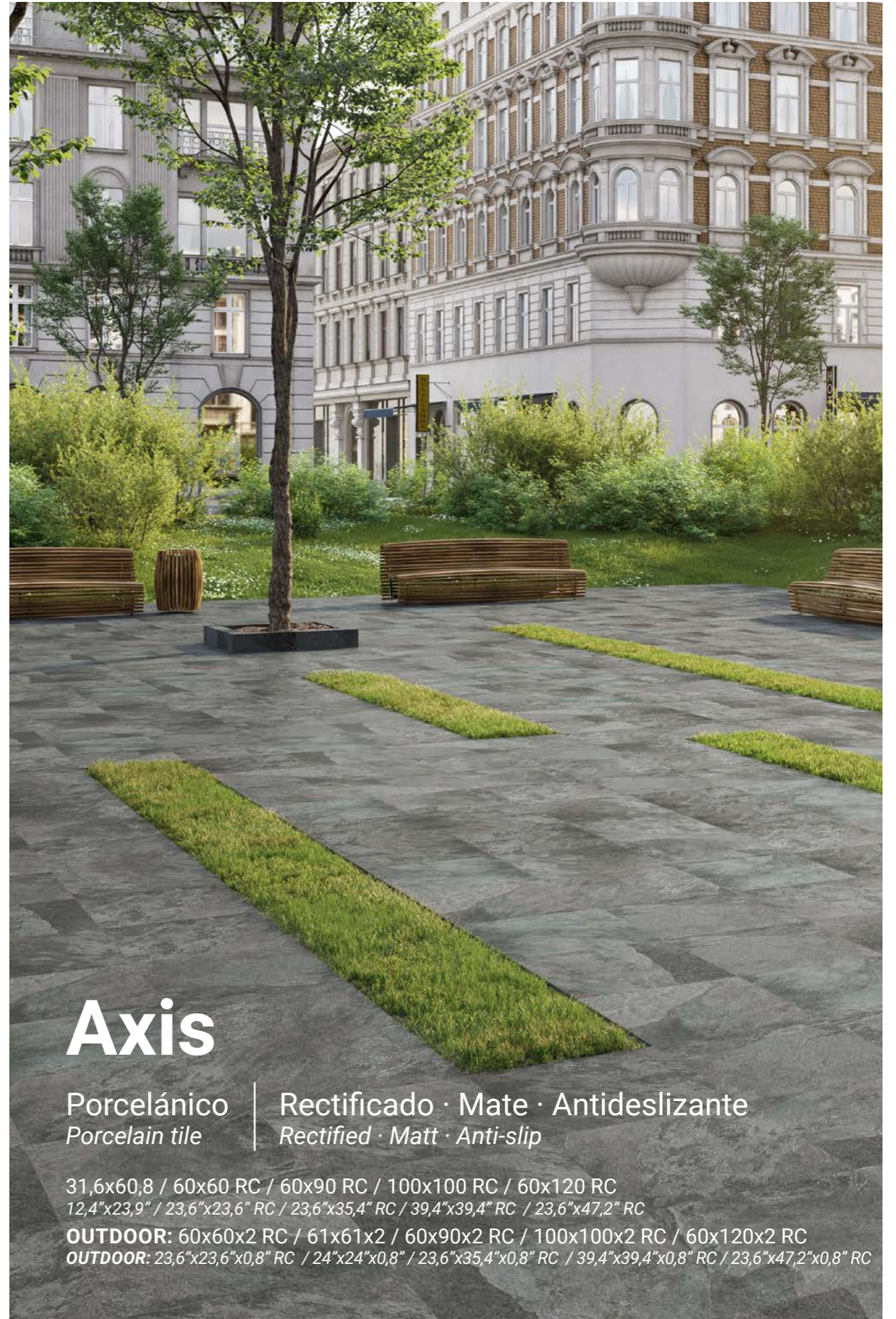

# Axis

Porcelánico  
Porcelain tile

Rectificado · Mate · Antideslizante  
Rectified · Matt · Anti-slip

31,6x60,8 / 60x60 RC / 60x90 RC / 100x100 RC / 60x120 RC  
12,4"x23,9" / 23,6"x23,6" RC / 23,6"x35,4" RC / 39,4"x39,4" RC / 23,6"x47,2" RC

**OUTDOOR:** 60x60x2 RC / 61x61x2 / 60x90x2 RC / 100x100x2 RC / 60x120x2 RC  
**OUTDOOR:** 23,6"x23,6"x0,8" RC / 24"x24"x0,8" / 23,6"x35,4"x0,8" RC / 39,4"x39,4"x0,8" RC / 23,6"x47,2"x0,8" RC



OUTDOOR

**31,6 x 60,8**

AXIS WHITE CTE2/R10 / B186  
AXIS WHITE CTE3/R11/C / B186  
AXIS GREY CTE2/R10 / B186  
AXIS GREY CTE3/R11/C / B186  
AXIS BLACK CTE2/R10 / B186  
AXIS BLACK CTE3/R11/C / B186  
AXIS CREAM CTE2/R10 / B186  
AXIS CREAM CTE3/R11/C / B186

**60 x 60 RC**

AXIS WHITE CTE2/R10 / B226  
AXIS GREY CTE2/R10 / B226  
AXIS BLACK CTE2/R10 / B226  
AXIS CREAM CTE2/R10 / B226

**60 x 90 RC**

AXIS WHITE CTE2/R10 / B273  
AXIS GREY CTE2/R10 / B273  
AXIS BLACK CTE2/R10 / B273  
AXIS CREAM CTE2/R10 / B273

**100 x 100 RC**

AXIS WHITE CTE2/R10 / B310  
AXIS GREY CTE2/R10 / B310  
AXIS BLACK CTE2/R10 / B310  
AXIS CREAM CTE2/R10 / B310

**60 x 120 RC**

AXIS WHITE CTE2/R10 / B310  
AXIS GREY CTE2/R10 / B310  
AXIS BLACK CTE2/R10 / B310  
AXIS CREAM CTE2/R10 / B310

**60 x 60 x 2 RC**

AXIS 20 WHITE CTE3/R11/C / B410  
AXIS 20 GREY CTE3/R11/C / B410  
AXIS 20 BLACK CTE3/R11/C / B410  
AXIS 20 CREAM CTE3/R11/C / B410

**61 x 61 x 2**

AXIS 20 WHITE CTE3/R11/C / B360  
AXIS 20 GREY CTE3/R11/C / B360  
AXIS 20 BLACK CTE3/R11/C / B360  
AXIS 20 CREAM CTE3/R11/C / B360

**60 x 90 x 2 RC**

AXIS 20 WHITE CTE3/R11/C / B524  
AXIS 20 GREY CTE3/R11/C / B524  
AXIS 20 BLACK CTE3/R11/C / B524  
AXIS 20 CREAM CTE3/R11/C / B524

**100 x 100 x 2 RC**

AXIS 20 WHITE CTE3/R11/C / B360  
AXIS 20 GREY CTE3/R11/C / B360  
AXIS 20 BLACK CTE3/R11/C / B360  
AXIS 20 CREAM CTE3/R11/C / B360

**60 x 120 x 2 RC**

AXIS 20 WHITE CTE3/R11/C / B600  
AXIS 20 GREY CTE3/R11/C / B600  
AXIS 20 BLACK CTE3/R11/C / B600  
AXIS 20 CREAM CTE3/R11/C / B600

EJEMPLO DE VARIEDAD GRÁFICA  
GRAPHIC VARIETY EXAMPLE



AXIS GREY 60x120 RC  
AXIS GREY 23,6"x47,2" RC



MS AXIS WHITE  
29,5x29,5 / C83

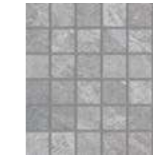

MS AXIS GREY  
29,5x29,5 / C83

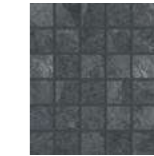

MS AXIS BLACK  
29,5x29,5 / C83



MS AXIS CREAM  
29,5x29,5 / C83

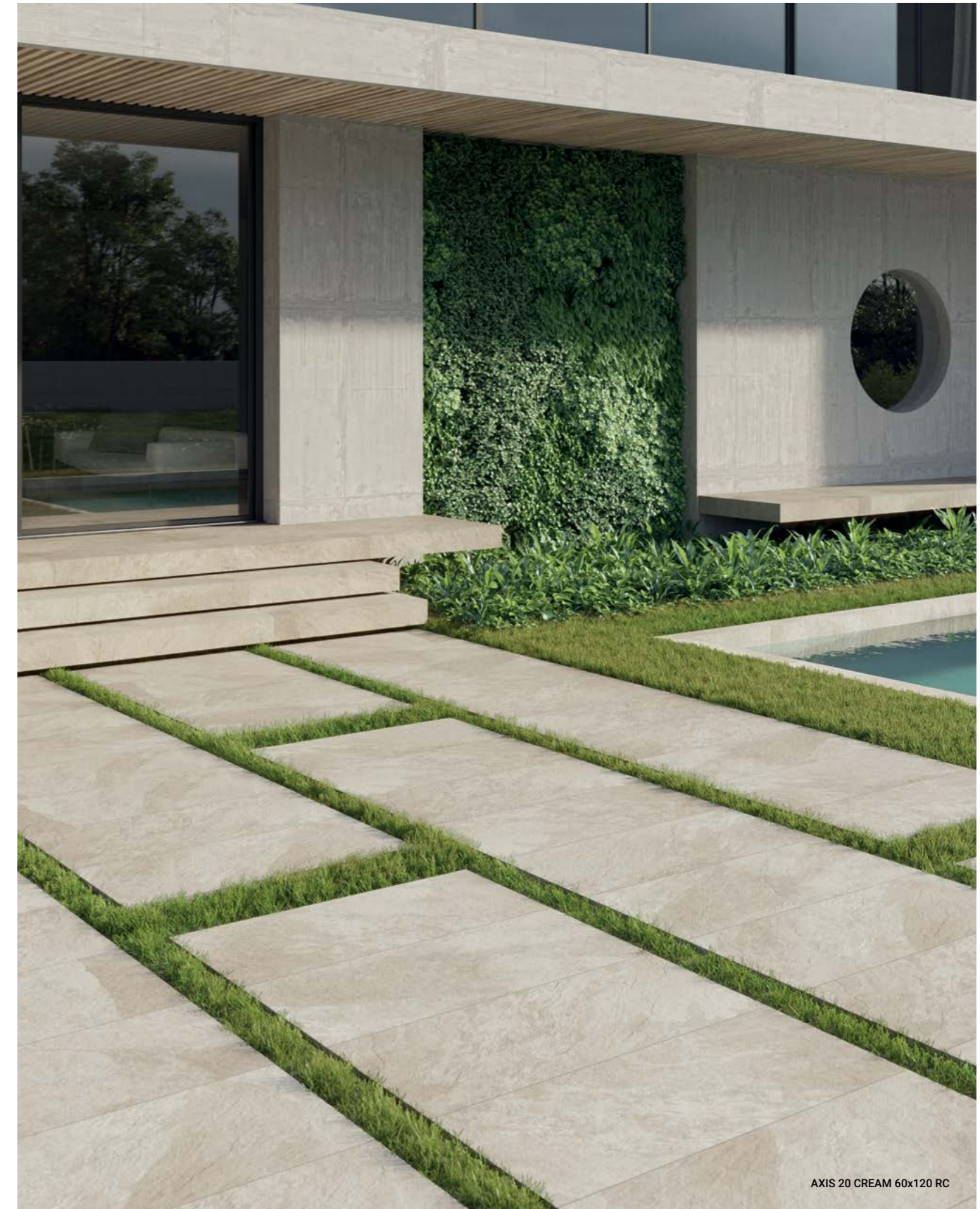

AXIS 20 CREAM 60x120 RC





white

grey

graphite

cream

taupe



# Burlington

Porcelánico  
Porcelain tile

Rectificado · Mate  
Rectified · Matt

31,6x60,8 / 47,2x47,2 / 60x90 RC / 60x120 RC / 100x100 RC  
12,4"x23,9" / 18,6"x18,6" / 23,6"x35,4" RC / 23,6"x47,2" RC / 39,4"x39,4" RC

REVESTIMIENTO: 20x60

WALL TILE: 7,9"x23,6"

OUTDOOR: 60x90x2 RC / 100x100x2 RC

OUTDOOR: 23,6"x35,4"x0,8" RC / 39,4"x39,4"x0,8" RC

OUTDOOR 20<sup>th</sup> EDITION

**20 x 60**  
REVESTIMIENTO  
WALL TILE

32% 14% 75%

BURLINGTON WHITE / B115  
BURLINGTON GREY / B115  
BURLINGTON CREAM / B115  
BURLINGTON TAUPE / B115

**31,6 x 60,8**

29% 7% 77%

BURLINGTON WHITE CTE1/R9 / B186  
BURLINGTON GREY CTE1/R9 / B186  
BURLINGTON GRAPHITE CTE1/R9 / B186  
BURLINGTON CREAM CTE1/R9 / B186  
BURLINGTON TAUPE CTE1/R9 / B186

**47,2 x 47,2**

29% 7% 77%

BURLINGTON WHITE CTE1/R9 / B186  
BURLINGTON GREY CTE1/R9 / B186  
BURLINGTON CREAM CTE1/R9 / B186  
BURLINGTON TAUPE CTE1/R9 / B186

**60 x 90 RC**

29% 7% 77%

BURLINGTON WHITE CTE1/R9 / B273  
BURLINGTON GREY CTE1/R9 / B273  
BURLINGTON GRAPHITE CTE1/R9 / B273  
BURLINGTON CREAM CTE1/R9 / B273

**60 x 90 x 2 RC**

29% 7% 77%

BURLINGTON 20 WHITE CTE3/R11/C / B524  
BURLINGTON 20 GREY CTE3/R11/C / B524  
BURLINGTON 20 GRAPHITE CTE3/R11/C / B524  
BURLINGTON 20 CREAM CTE3/R11/C / B524

**100 x 100 RC**

29% 7% 77%

BURLINGTON 20 WHITE CTE3/R11/C / B600  
BURLINGTON 20 GREY CTE3/R11/C / B600  
BURLINGTON 20 GRAPHITE CTE3/R11/C / B600  
BURLINGTON 20 CREAM CTE3/R11/C / B600

**100 x 100 RC**

29% 7% 77%

BURLINGTON WHITE CTE2/R10 / B310  
BURLINGTON GREY CTE2/R10 / B310  
BURLINGTON GRAPHITE CTE2/R10 / B310  
BURLINGTON CREAM CTE2/R10 / B310

**60 x 120 RC**

29% 7% 77%

BURLINGTON WHITE CTE1/R9 / B310  
BURLINGTON GREY CTE1/R9 / B310  
BURLINGTON GRAPHITE CTE1/R9 / B310  
BURLINGTON CREAM CTE1/R9 / B310  
BURLINGTON TAUPE CTE1/R9 / B310

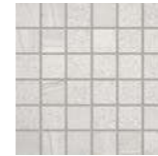

MS BURLINGTON WHITE  
29,5x29,5 / C77



MS BURLINGTON GREY  
29,5x29,5 / C77

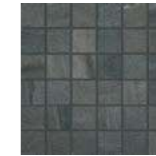

MS BURLINGTON GRAPHITE  
29,5x29,5 / C77



MS BURLINGTON CREAM  
29,5x29,5 / C77



MS BURLINGTON TAUPE  
29,5x29,5 / C77



BURLINGTON GREY 60x120 RC



BURLINGTON-REL WHITE  
20x60 / B138

BURLINGTON DEC-2 WHITE  
20x60 / B138

BURLINGTON-REL GREY  
20x60 / B138



BURLINGTON-REL CREAM  
20x60 / B138

BURLINGTON DEC-2 CREAM  
20x60 / B138

BURLINGTON-REL TAUPE  
20x60 / B138

EJEMPLO DE VARIEDAD GRÁFICA  
GRAPHIC VARIETY EXAMPLE



BURLINGTON GREY 20x60  
BURLINGTON GREY 7,9"x26,6"

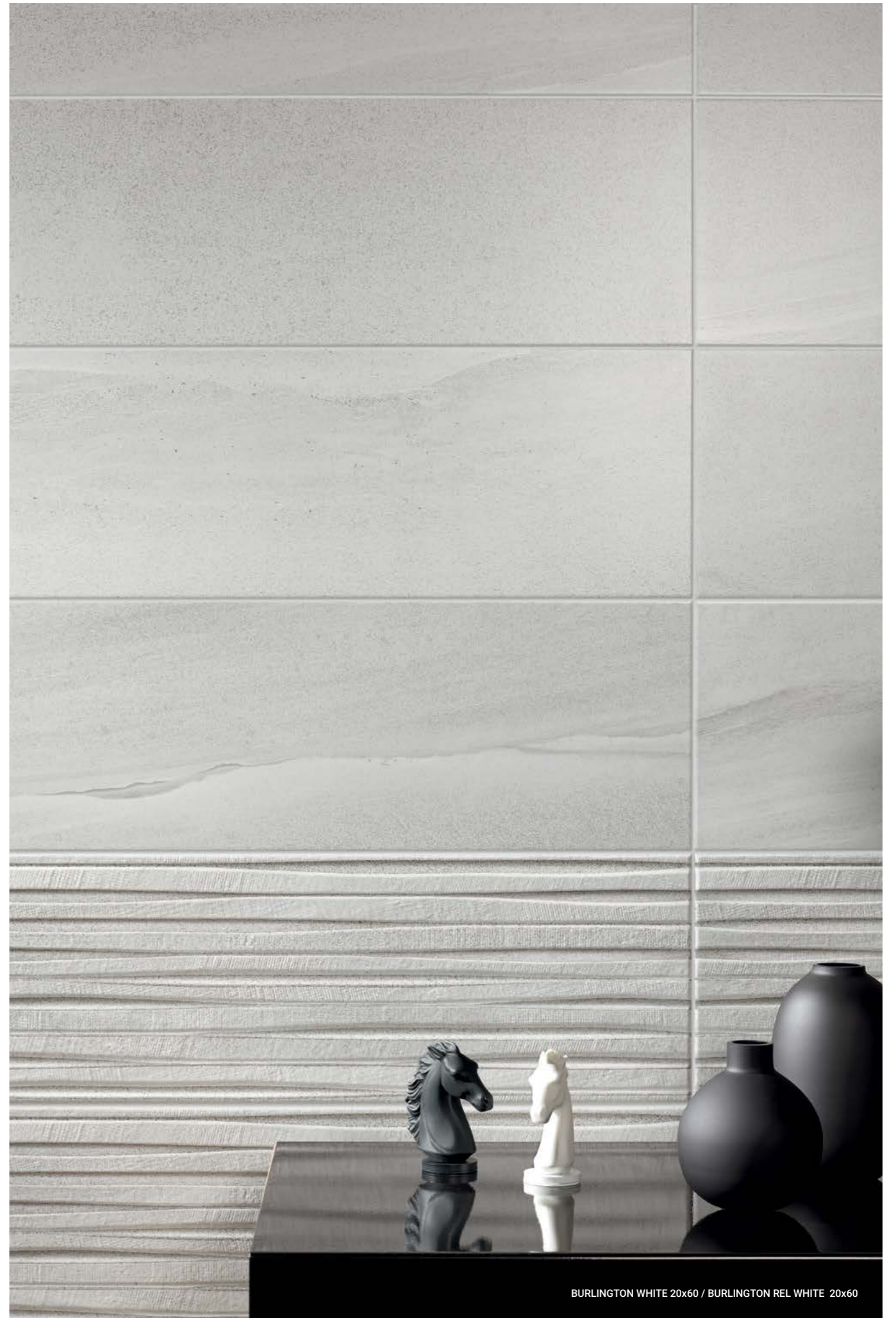

BURLINGTON WHITE 20x60 / BURLINGTON REL WHITE 20x60



white



grey



cream



# Chrono

Porcelánico | Rectificado · Mate  
Porcelain tile | Rectified · Matt

31,6x60,8 / 47,2x47,2 / 60x120 RC  
12,4"x23,9" / 18,6"x18,6" / 23,6"x47,2" RC

REVESTIMIENTO: 20x60

WALL TILE: 7,9"x23,6"

OUTDOOR: 60x60x2 RC / 60x120x2 RC  
OUTDOOR: 23,6"x23,6"x0,8" / 23,6"x47,2"x0,8" RC

OUTDOOR



CHRONO WHITE / B115  
CHRONO GREY / B115  
CHRONO CREAM / B115



CHRONO WHITE CTE1/R9 / B186  
CHRONO GREY CTE1/R9 / B186  
CHRONO CREAM CTE1/R9 / B186

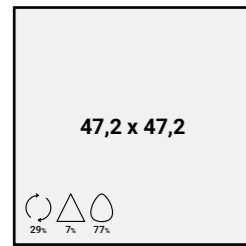

CHRONO WHITE / B186  
CHRONO GREY / B186  
CHRONO CREAM / B186



CHRONO 20 WHITE CTE3/R11/C / B410  
CHRONO 20 GREY CTE3/R11/C / B410  
CHRONO 20 CREAM CTE3/R11/C / B410

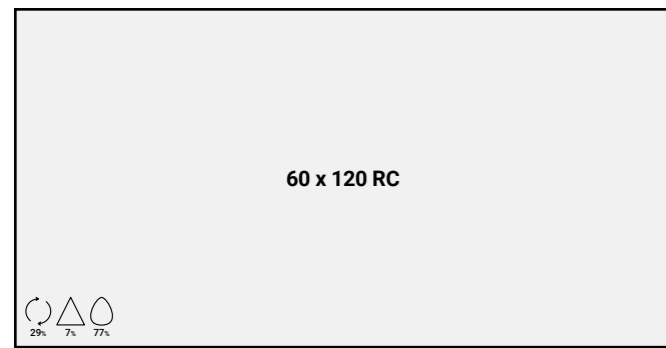

CHRONO WHITE CTE2/R10 / B310  
CHRONO GREY CTE2/R10 / B310  
CHRONO CREAM CTE2/R10 / B310

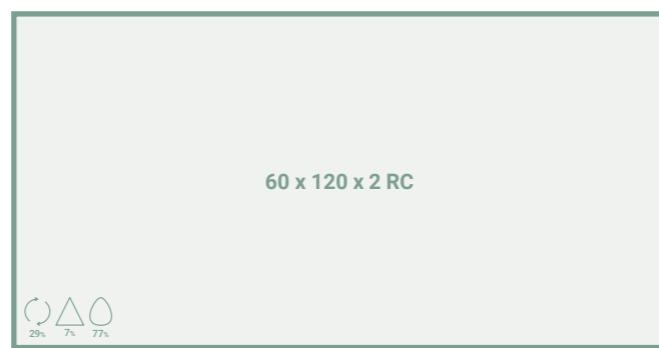

CHRONO 20 WHITE CTE3/R11/C / B600  
CHRONO 20 GREY CTE3/R11/C / B600  
CHRONO 20 CREAM CTE3/R11/C / B600

PAVIMENTO COORDINADO  
COORDINATED FLOOR TILE



CHRONO WHITE  
47,2x47,2 / B186



CHRONO GREY  
47,2x47,2 / B186



CHRONO CREAM  
47,2x47,2 / B186

EJEMPLO DE VARIEDAD GRÁFICA  
GRAPHIC VARIETY EXAMPLE



CHRONO CREAM 60x120 RC  
CHRONO CREAM 23,6"x47,2" RC

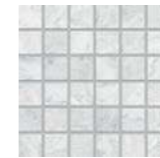

MS CHRONO WHITE  
30x30 / C77



CHRONO-REL WHITE  
31,6x60,8 / B205



CHRONO-REL WHITE  
20x60 / B138



MS CHRONO GREY  
30x30 / C77



CHRONO-REL GREY  
31,6x60,8 / B205



CHRONO-REL GREY  
20x60 / B138



MS CHRONO CREAM  
30x30 / C77



CHRONO-REL CREAM  
31,6x60,8 / B205



CHRONO-REL CREAM  
20x60 / B138



CHRONO CREAM 60x120 RC / CHRONO CREAM 31,6x60,8 / CHRONO REL CREAM 31,6x60,8



smoke



grey

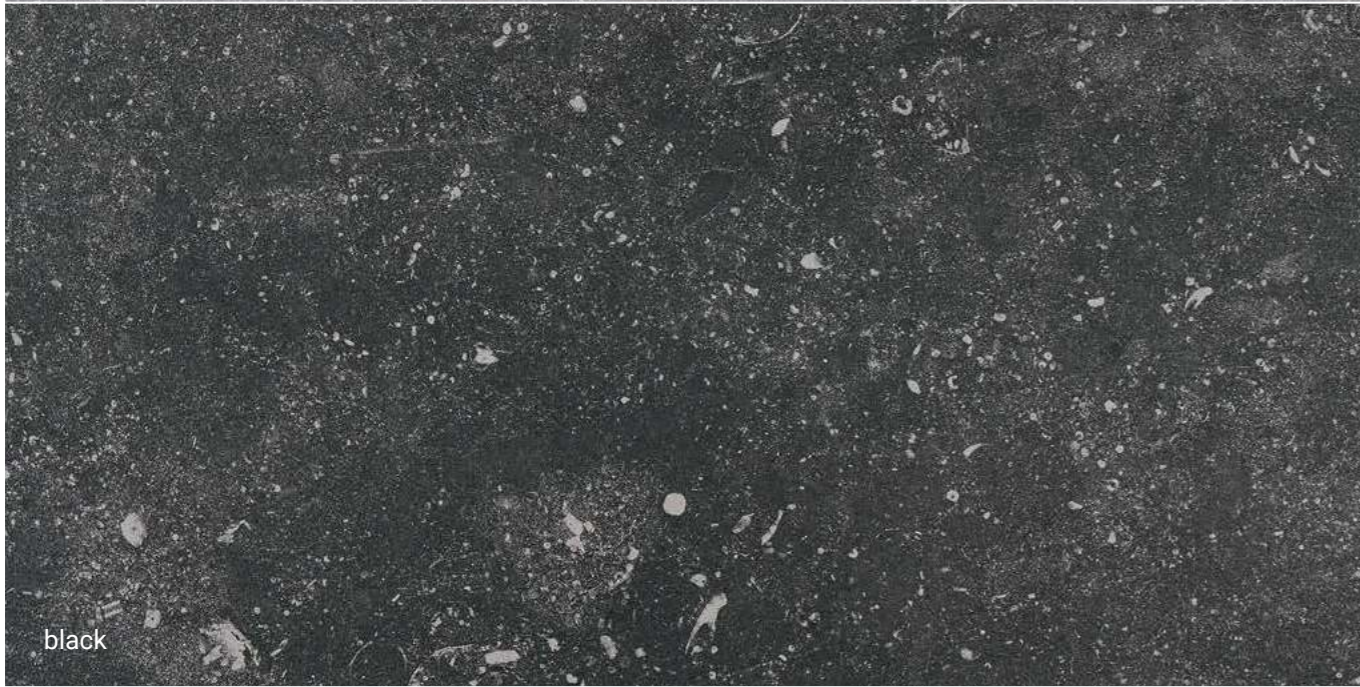

black



# Citadel

Porcelánico  
Porcelain tile

Rectificado · Mate  
Rectified · Matt

60x60 RC / 60x120 RC / 75x75 RC  
23,6"x23,6" RC / 23,6"x47,2" RC / 29,5"x29,5" RC  
**OUTDOOR:** 60x120x2 RC / 75x75x2 RC  
**OUTDOOR:** 23,6"x47,2"x0,8" RC / 29,5"x29,5"x0,8" RC

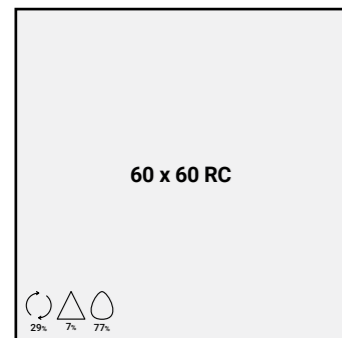

CITADEL SMOKE / B226  
CITADEL GREY / B226  
CITADEL BLACK / B226

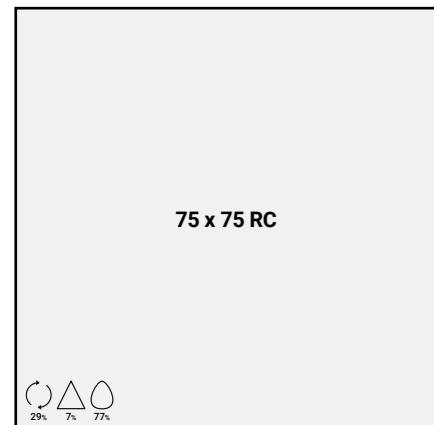

CITADEL SMOKE / B273  
CITADEL GREY / B273  
CITADEL BLACK / B273



CITADEL 20 SMOKE CTE3/R11/C / B524  
CITADEL 20 GREY CTE3/R11/C / B524  
CITADEL 20 BLACK CTE3/R11/C / B524

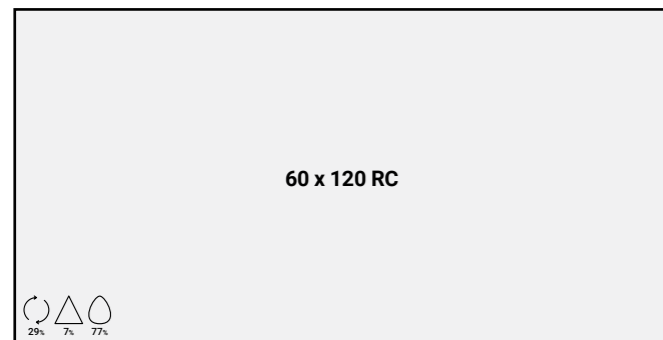

CITADEL SMOKE / B310  
CITADEL GREY / B310  
CITADEL BLACK / B310

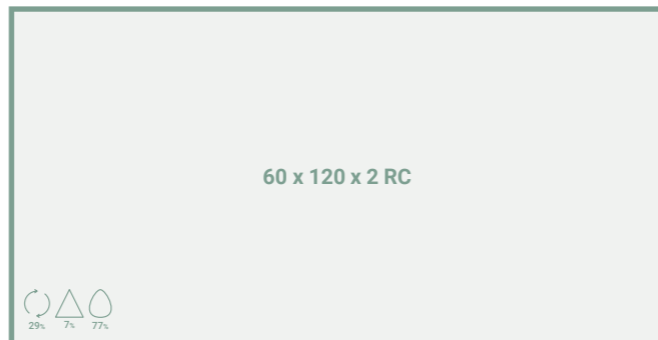

CITADEL 20 SMOKE CTE3/R11/C / B600  
CITADEL 20 GREY CTE3/R11/C / B600  
CITADEL 20 BLACK CTE3/R11/C / B600

EJEMPLO DE VARIEDAD GRÁFICA  
GRAPHIC VARIETY EXAMPLE



CITADEL GREY 75x75 RC  
CITADEL GREY 29,5"x29,5" RC



CITADEL BLACK 60x120 RC / CITADEL GREY 60x120 RC / CITADEL BLACK 75x75 RC



cotton



bianco



calcite

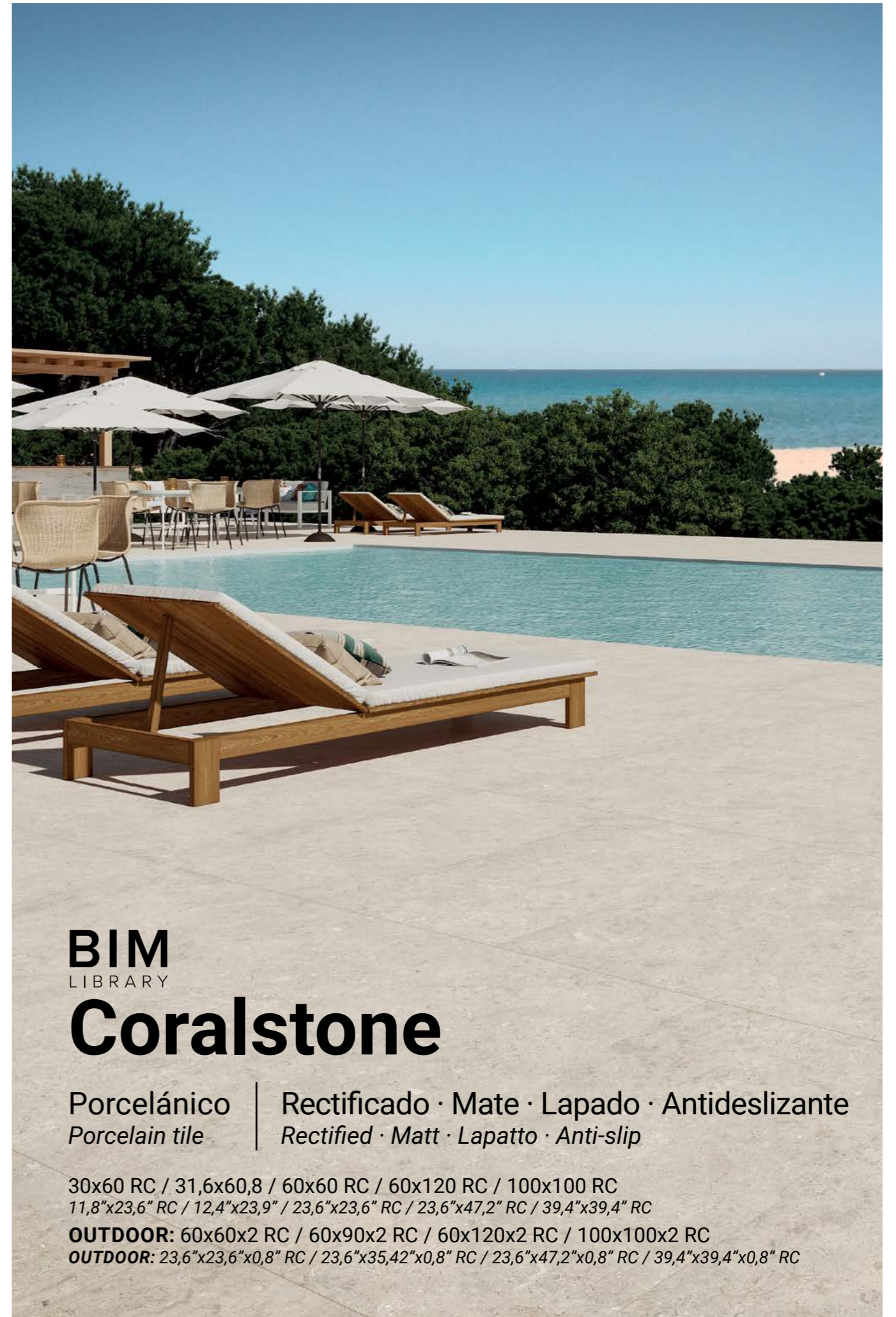

**BIM**  
LIBRARY

# Coralstone

Porcelánico  
*Porcelain tile*

Rectificado · Mate · Lapado · Antideslizante  
*Rectified · Matt · Lapatto · Anti-slip*

30x60 RC / 31,6x60,8 / 60x60 RC / 60x120 RC / 100x100 RC  
11,8"x23,6" RC / 12,4"x23,9" / 23,6"x23,6" RC / 23,6"x47,2" RC / 39,4"x39,4" RC

**OUTDOOR:** 60x60x2 RC / 60x90x2 RC / 60x120x2 RC / 100x100x2 RC

**OUTDOOR:** 23,6"x23,6"x0,8" RC / 23,6"x35,42"x0,8" RC / 23,6"x47,2"x0,8" RC / 39,4"x39,4"x0,8" RC



OUTDOOR 20<sup>th</sup> EDITION

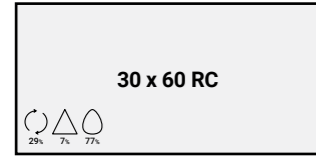

CORALSTONE COTTONE CTE2/R10 / B226  
CORALSTONE BIANCO CTE2/R10 / B226  
CORALSTONE CALCITE CTE2/R10 / B226

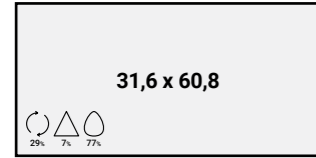

CORALSTONE COTTONE CTE2/R10 / B186  
CORALSTONE COTTONE CTE3/R11/C / B186  
CORALSTONE BIANCO CTE2/R10 / B186  
CORALSTONE BIANCO CTE3/R11/C / B186  
CORALSTONE CALCITE CTE2/R10 / B186  
CORALSTONE CALCITE CTE3/R11/C / B186



CORALSTONE 20 COTTONE CTE3/R11/C / B410  
CORALSTONE 20 BIANCO CTE3/R11/C / B410  
CORALSTONE 20 CALCITE CTE3/R11/C / B410

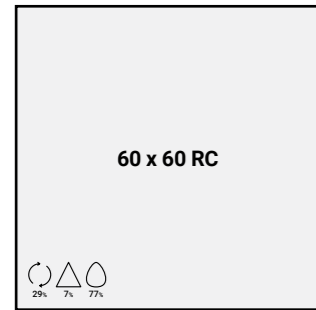

CORALSTONE COTTONE CTE2/R10 / B226  
CORALSTONE COTTONE CTE3/R11/C / B226  
CORALSTONE BIANCO CTE2/R10 / B226  
CORALSTONE BIANCO CTE3/R11/C / B226  
CORALSTONE CALCITE CTE2/R10 / B226  
CORALSTONE CALCITE CTE3/R11/C / B226



CORALSTONE 20 COTTONE CTE3/R11/C / B524  
CORALSTONE 20 BIANCO CTE3/R11/C / B524  
CORALSTONE 20 CALCITE CTE3/R11/C / B524

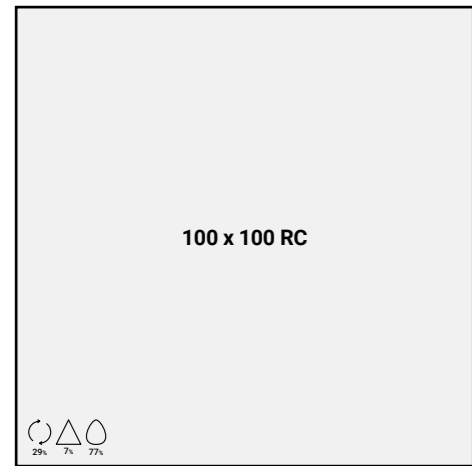

CORALSTONE COTTONE CTE2/R10 / B310  
CORALSTONE COTTONE CTE3/R11/C / B310  
CORALSTONE COTTONE LAP / B430  
CORALSTONE BIANCO CTE2/R10 / B310  
CORALSTONE BIANCO CTE3/R11/C / B310  
CORALSTONE BIANCO LAP / B430  
CORALSTONE CALCITE CTE2/R10 / B310  
CORALSTONE CALCITE CTE3/R11/C / B310  
CORALSTONE CALCITE LAP / B430

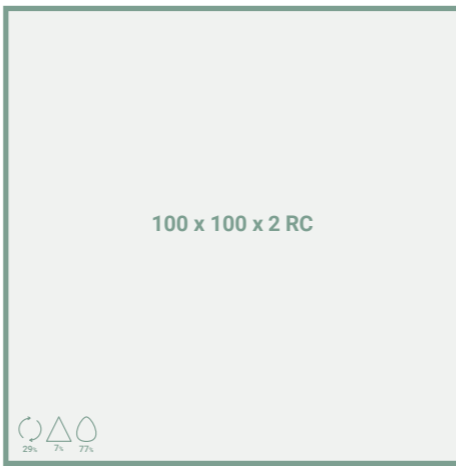

CORALSTONE 20 COTTONE CTE3/R11/C / B600  
CORALSTONE 20 BIANCO CTE3/R11/C / B600  
CORALSTONE 20 CALCITE CTE3/R11/C / B600

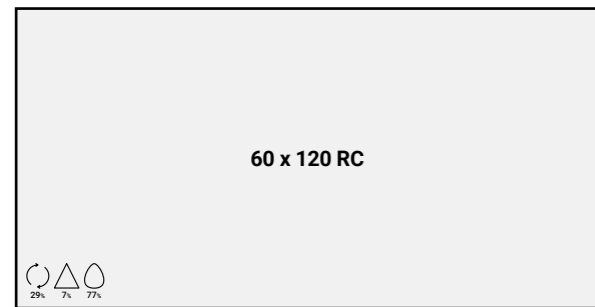

CORALSTONE COTTONE CTE2/R10 / B310  
CORALSTONE COTTONE LAP / B430  
CORALSTONE BIANCO CTE2/R10 / B310  
CORALSTONE BIANCO LAP / B430  
CORALSTONE CALCITE CTE2/R10 / B310  
CORALSTONE CALCITE LAP / B430



CORALSTONE 20 COTTONE CTE3/R11/C / B600  
CORALSTONE 20 BIANCO CTE3/R11/C / B600  
CORALSTONE 20 CALCITE CTE3/R11/C / B600

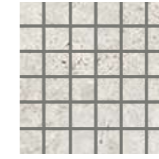

MS CORALSTONE COTTONE  
30x30 / C65

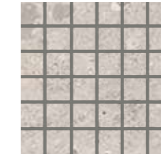

MS CORALSTONE BIANCO  
30x30 / C65

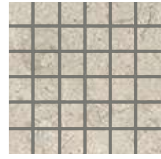

MS CORALSTONE  
CALCITE  
30x30 / C65



CORALSTONE-REL COTTONE  
31,6x60,8 / B205



CORALSTONE-REL BIANCO  
31,6x60,8 / B205



CORALSTONE-REL CALCITE  
31,6x60,8 / B205



CORALSTONE-DEC MARE 20 COTTONE CTE3/R11/C  
60x60 RC / B410



CORALSTONE-DEC MARE 20 BIANCO CTE3/R11/C  
60x60 RC / B410



CORALSTONE-DEC MARE 20 CALCITE CTE3/R11/C  
60x60 RC / B410

EJEMPLO DE VARIEDAD GRÁFICA  
GRAPHIC VARIETY EXAMPLE

CORALSTONE CALCITE 60x60 RC  
CORALSTONE CALCITE 23,6"x23,6"



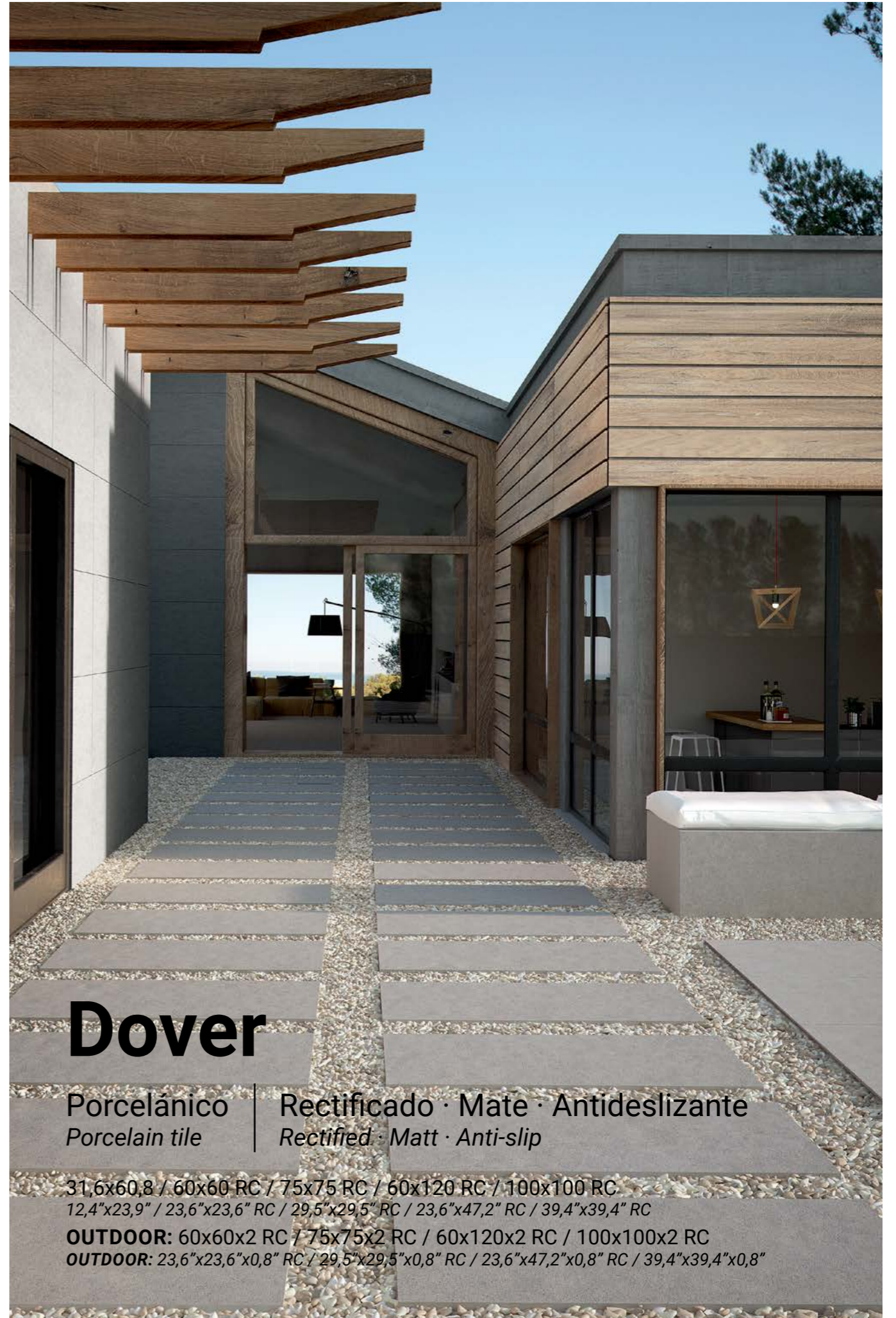

# Dover

Porcelánico  
Porcelain tile

Rectificado · Mate · Antideslizante  
Rectified · Matt · Anti-slip

31,6x60,8 / 60x60 RC / 75x75 RC / 60x120 RC / 100x100 RC  
12,4"x23,9" / 23,6"x23,6" RC / 29,5"x29,5" RC / 23,6"x47,2" RC / 39,4"x39,4" RC

**OUTDOOR:** 60x60x2 RC / 75x75x2 RC / 60x120x2 RC / 100x100x2 RC

**OUTDOOR:** 23,6"x23,6"x0,8" RC / 29,5"x29,5"x0,8" RC / 23,6"x47,2"x0,8" RC / 39,4"x39,4"x0,8"

OUTDOOR

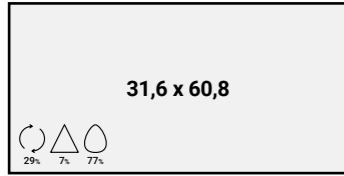

DOVER WHITE CTE1/R9 / B186  
DOVER SMOKE CTE1/R9 / B186  
DOVER GREY CTE1/R9 / B186  
DOVER CREAM CTE1/R9 / B186

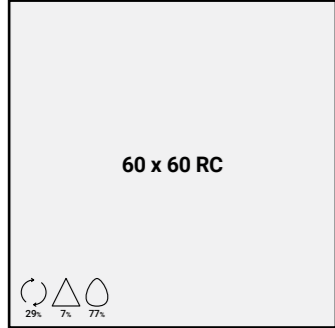

DOVER WHITE CTE2/R10 / B226  
DOVER SMOKE CTE2/R10 / B226  
DOVER GREY CTE2/R10 / B226  
DOVER CREAM CTE2/R10 / B226



DOVER 20 WHITE CTE3/R11/C / B410  
DOVER 20 SMOKE CTE3/R11/C / B410  
DOVER 20 GREY CTE3/R11/C / B410  
DOVER 20 CREAM CTE3/R11/C / B410

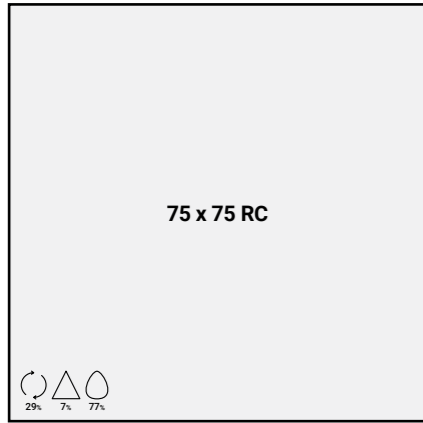

DOVER WHITE CTE2/R10 / B273  
DOVER SMOKE CTE2/R10 / B273  
DOVER SMOKE CTE3/R11/C / B273  
DOVER GREY CTE2/R10 / B273  
DOVER CREAM CTE2/R10 / B273  
DOVER CREAM CTE3/R11/C / B273



DOVER 20 WHITE CTE3/R11/C / B524  
DOVER 20 SMOKE CTE3/R11/C / B524  
DOVER 20 GREY CTE3/R11/C / B524  
DOVER 20 CREAM CTE3/R11/C / B524

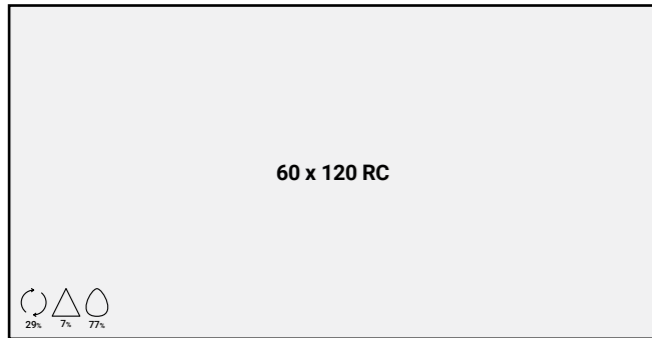

DOVER WHITE CTE2/R10 / B310  
DOVER SMOKE CTE2/R10 / B310  
DOVER GREY CTE2/R10 / B310  
DOVER CREAM CTE2/R10 / B310



DOVER 20 WHITE CTE3/R11/C / B600  
DOVER 20 SMOKE CTE3/R11/C / B600  
DOVER 20 GREY CTE3/R11/C / B600  
DOVER 20 CREAM CTE3/R11/C / B600

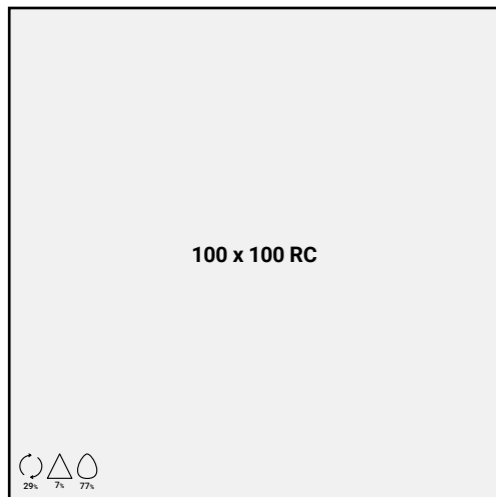

DOVER 20 WHITE CTE3/R11/C / B600  
DOVER 20 SMOKE CTE3/R11/C / B600  
DOVER 20 GREY CTE3/R11/C / B600  
DOVER 20 CREAM CTE3/R11/C / B600

DOVER WHITE CTE2/R10 / B310  
DOVER SMOKE CTE2/R10 / B310  
DOVER GREY CTE2/R10 / B310  
DOVER CREAM CTE2/R10 / B310

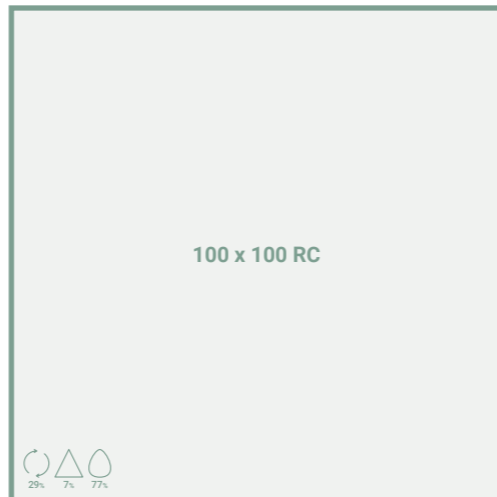

DOVER 20 WHITE CTE3/R11/C / B600  
DOVER 20 SMOKE CTE3/R11/C / B600  
DOVER 20 GREY CTE3/R11/C / B600  
DOVER 20 CREAM CTE3/R11/C / B600



MS DOVER WHITE  
29,5x29,5 / C116



MS DOVER SMOKE  
29,5x29,5 / C116



MS DOVER GREY  
29,5x29,5 / C116



MS DOVER CREAM  
29,5x29,5 / C116



DOVER-REL 2 WHITE  
31,6x60,8 / B205



DOVER-REL 2 SMOKE  
31,6x60,8 / B205



DOVER-REL 2 GREY  
31,6x60,8 / B205



DOVER-REL 2 CREAM  
31,6x60,8 / B205



DOVER CREAM 31,6x60,8 / DOVER REL 2 CREAM 31,6x60,8



blanco



beige



mix



negro



# Eifel

Porcelánico  
Porcelain tile

Mate · Antideslizante  
Matt · Anti-slip

31,6x60,8  
12,4"x23,9"

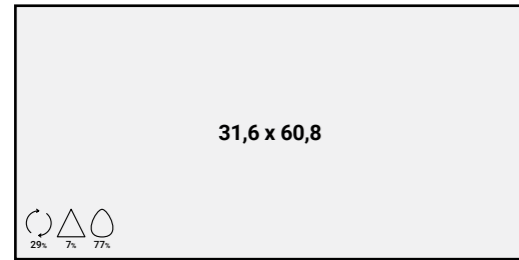

EIFEL BLANCO / B186  
 EIFEL BEIGE / B186  
 EIFEL MIX / B186  
 EIFEL NEGRO / B186

EJEMPLO DE VARIEDAD GRÁFICA  
 GRAPHIC VARIETY EXAMPLE



EIFEL BEIGE 31,6x60,8  
 EIFEL BEIGE 12,4"x23,9"



EIFEL NEGRO 31,6x60,8



white



grey



taupe

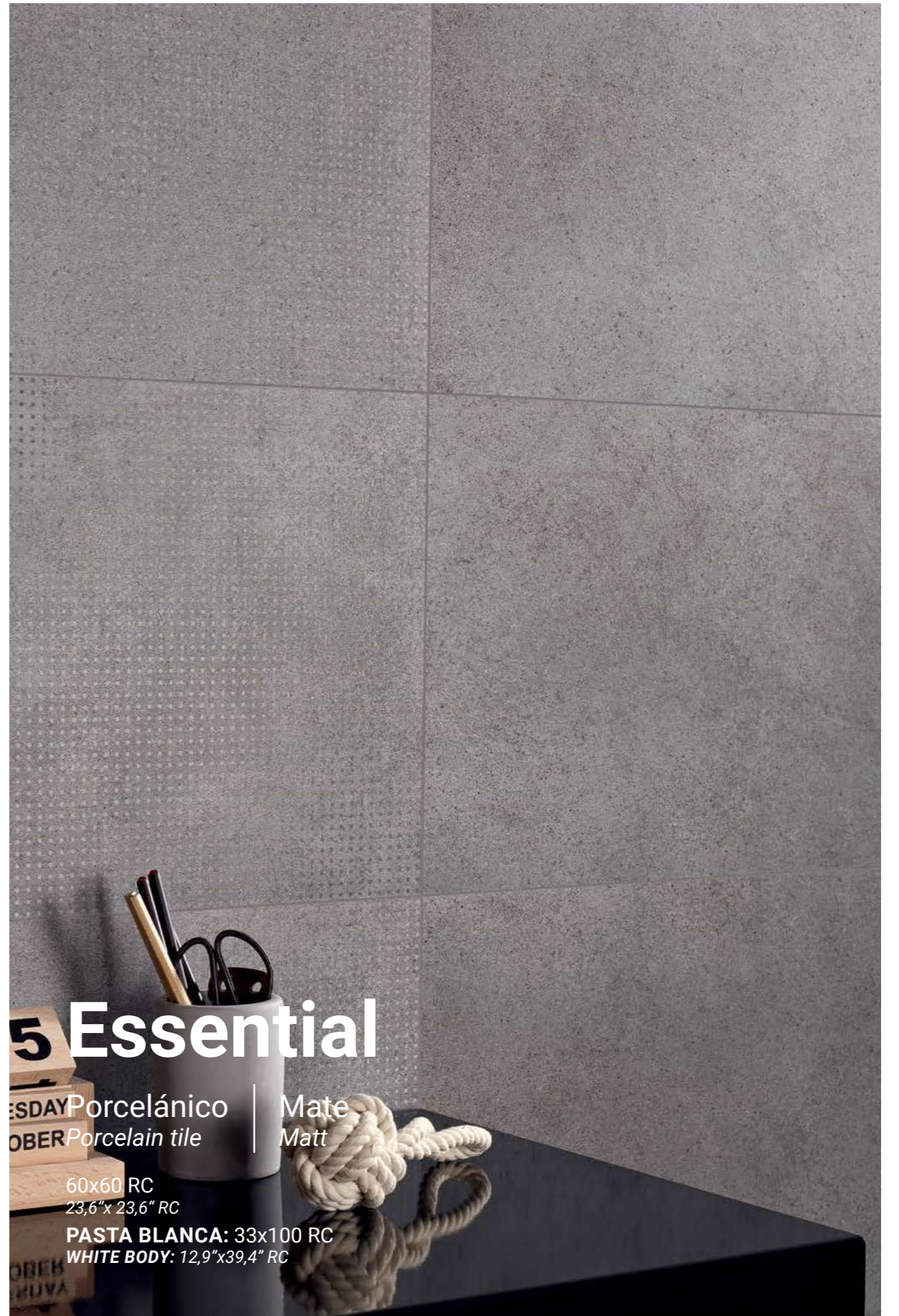

# 5 Essential

Porcelánico | Mate  
Porcelain tile | Matt

60x60 RC  
23,6" x 23,6" RC

PASTA BLANCA: 33x100 RC  
WHITE BODY: 12,9" x 39,4" RC



6mm ESPESOR  
6mm THICKNESS  
ESSENTIAL WHITE / B208  
ESSENTIAL GREY / B208  
ESSENTIAL TAUPE / B208

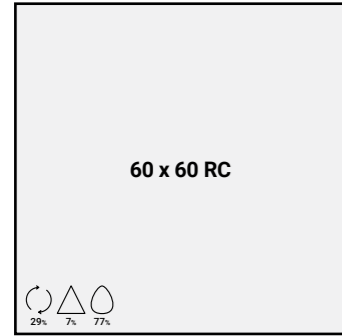

ESSENTIAL WHITE CT1/R10/A / B226  
ESSENTIAL GREY CT1/R10/A / B226  
ESSENTIAL TAUPE CT1/R10/A / B226

EJEMPLO DE VARIEDAD GRÁFICA  
GRAPHIC VARIETY EXAMPLE

ESSENTIAL GREY 60x60 RC  
ESSENTIAL GREY 23,6"x23,6" RC

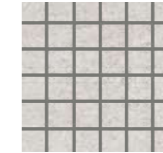

MS ESSENTIAL WHITE  
30x30 / C065

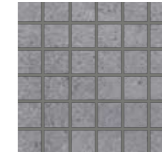

MS ESSENTIAL GREY  
30x30 / C065

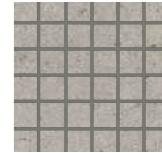

MS ESSENTIAL TAUPE  
30x30 / C065



ESSENTIAL REL WHITE / 33x100 RC / B230



ESSENTIAL DEC WHITE / 33x100 RC / B230

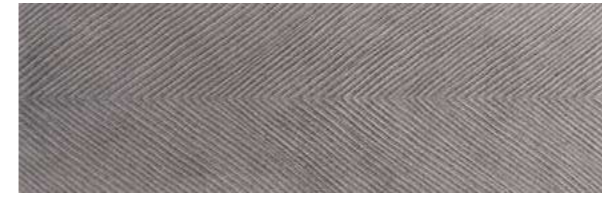

ESSENTIAL REL GREY / 33x100 RC / B230



ESSENTIAL DEC GREY / 33x100 RC / B230

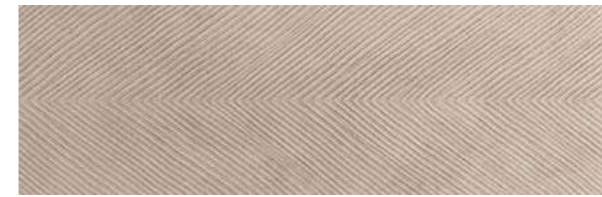

ESSENTIAL REL TAUPE / 33x100 RC / B230



ESSENTIAL DEC TAUPE / 33x100 RC / B230



ESSENTIAL DEC TAUPE 33x100 RC

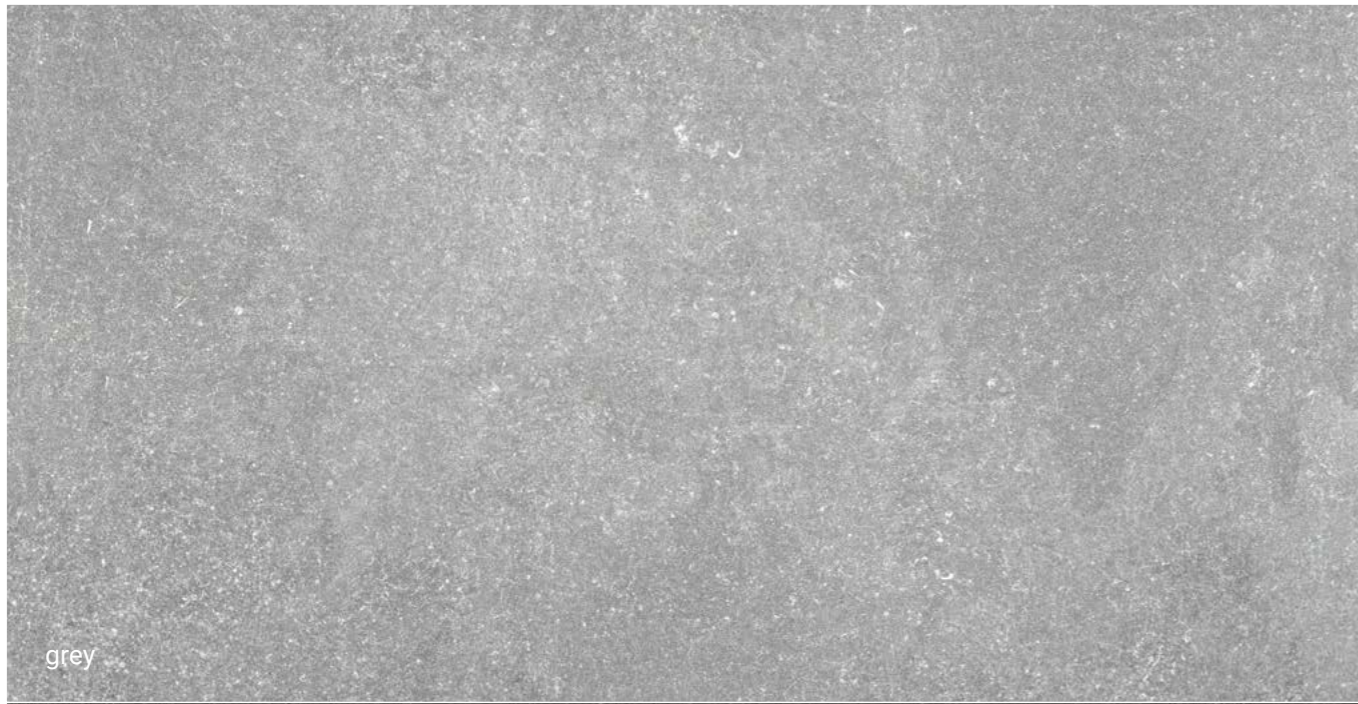

grey



graphite



dark

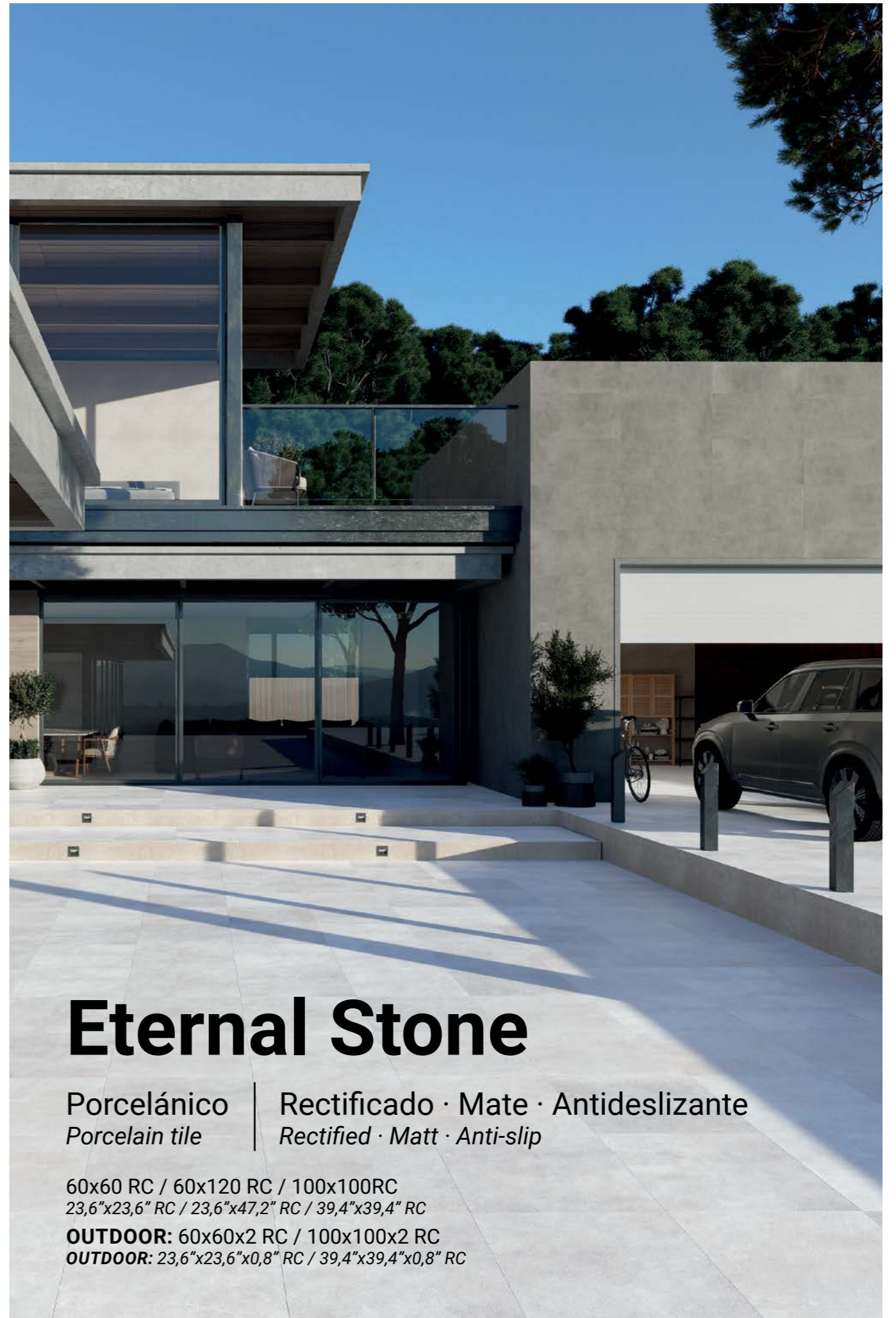

# Eternal Stone

Porcelánico  
*Porcelain tile*

Rectificado · Mate · Antideslizante  
*Rectified · Matt · Anti-slip*

60x60 RC / 60x120 RC / 100x100RC  
*23,6"x23,6" RC / 23,6"x47,2" RC / 39,4"x39,4" RC*

**OUTDOOR:** 60x60x2 RC / 100x100x2 RC  
*OUTDOOR: 23,6"x23,6"x0,8" RC / 39,4"x39,4"x0,8" RC*



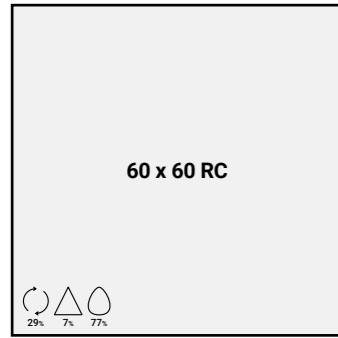

ETERNAL STONE GREY CTE1/R9 / B226  
ETERNAL STONE GRAPHITE CTE1/R9 / B226  
ETERNAL STONE DARK CTE1/R9 / B226

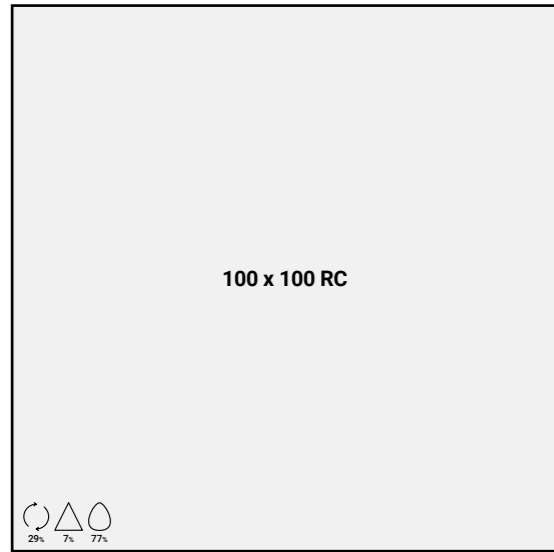

ETERNAL STONE GREY CTE1/R9 / B310  
ETERNAL STONE GREY CTE3/R11/C / B310  
ETERNAL STONE GRAPHITE CTE1/R9 / B310  
ETERNAL STONE GRAPHITE CTE3/R11/C / B310  
ETERNAL STONE DARK CTE1/R9 / B310  
ETERNAL STONE DARK CTE3/R11/C / B310



ETERNAL STONE GREY CTE1/R9 / B310  
ETERNAL STONE GRAPHITE CTE1/R9 / B310  
ETERNAL STONE DARK CTE1/R9 / B310



ETERNAL STONE 20 GREY CTE3/R11/C / B410  
ETERNAL STONE 20 GRAPHITE CTE3/R11/C / B410  
ETERNAL STONE 20 DARK CTE3/R11/C / B410

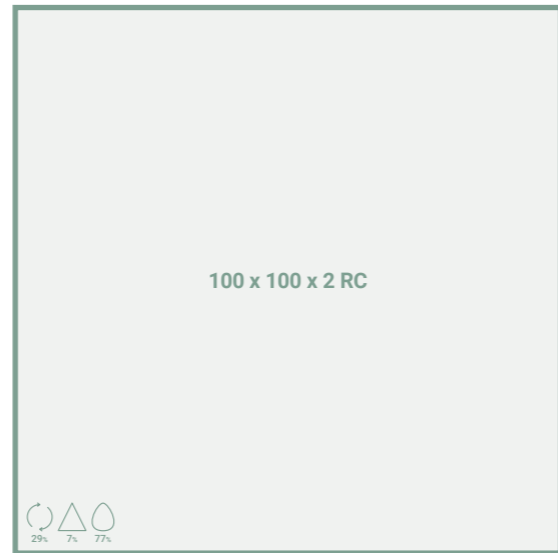

ETERNAL STONE 20 GREY CTE3/R11/C / B600  
ETERNAL STONE 20 GRAPHITE CTE3/R11/C / B600  
ETERNAL STONE 20 DARK CTE3/R11/C / B600

ETERNAL STONE GRAPHITE 60x120 RC  
ETERNAL STONE GRAPHITE 23,6"x47,2" RC

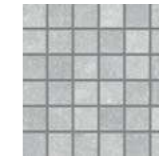

MS ETERNAL STONE  
GREY  
30x30 / C65

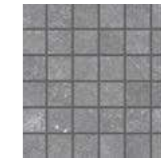

MS ETERNAL STONE  
GRAPHITE  
30x30 / C65

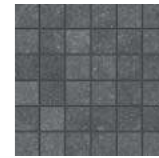

MS ETERNAL STONE  
DARK  
30x30 / C65



ETERNAL STONE 20 DARK 100x100 RC

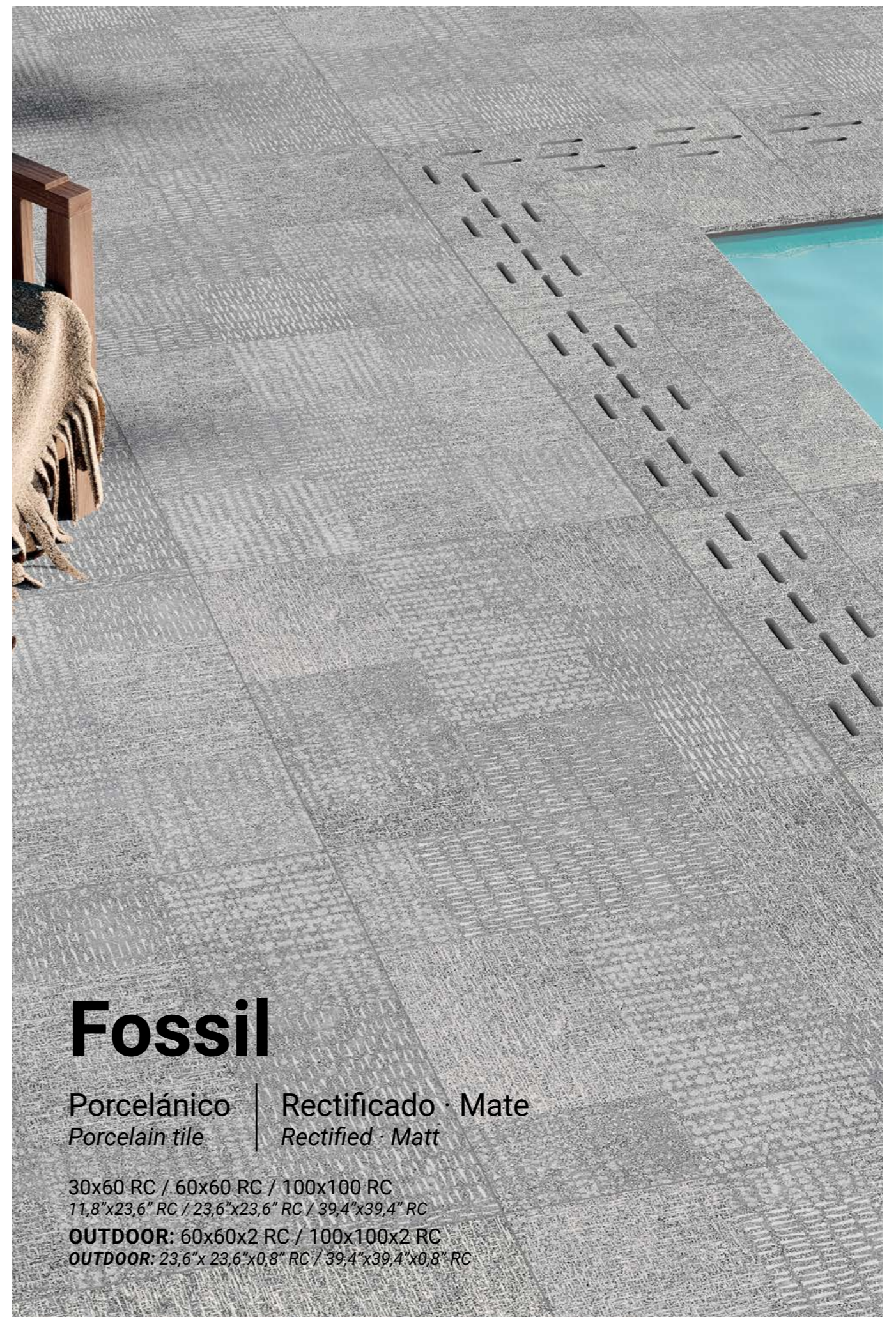
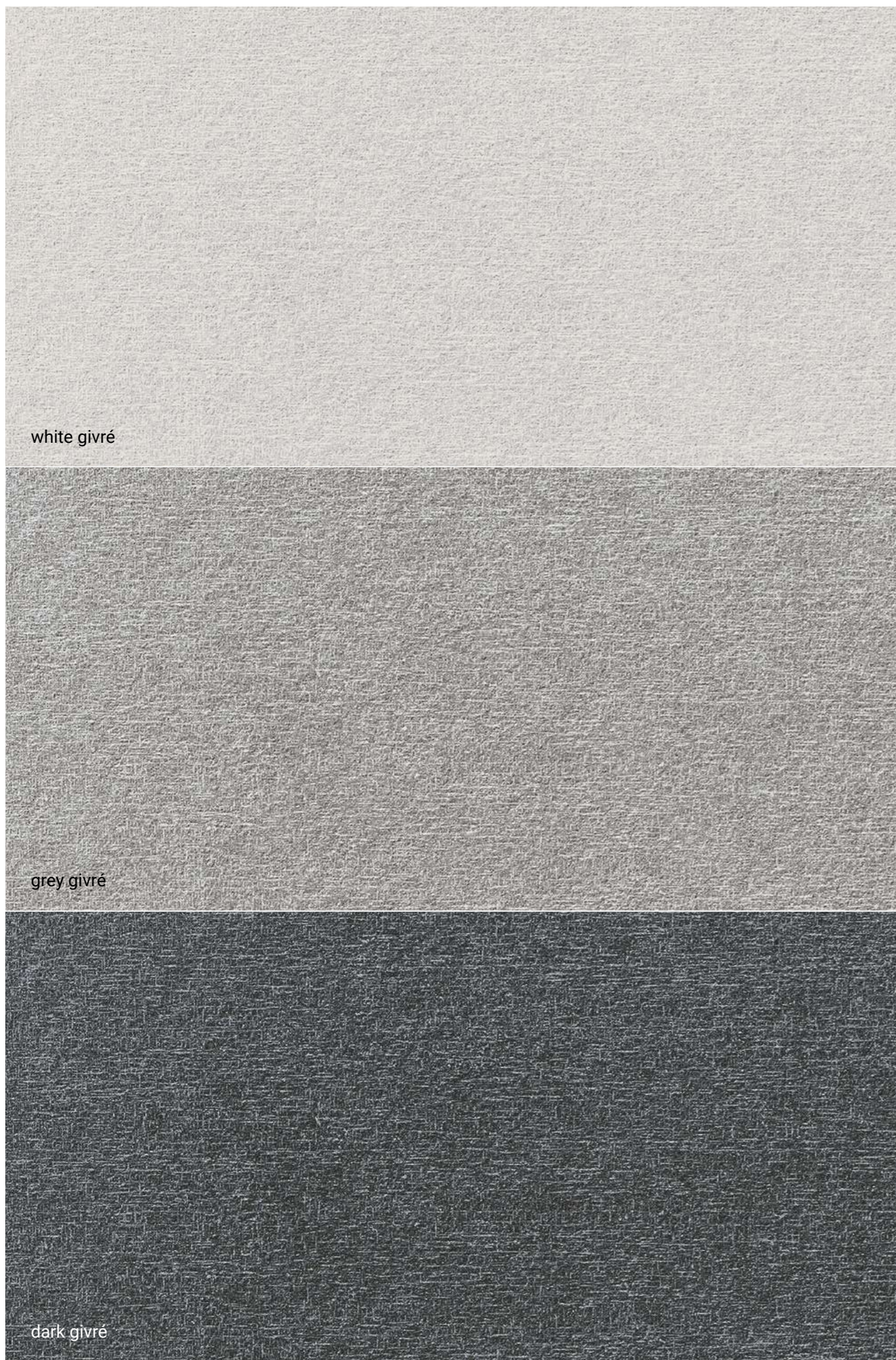

# Fossil

Porcelánico  
Porcelain tile

Rectificado · Mate  
Rectified · Matt

30x60 RC / 60x60 RC / 100x100 RC  
11,8"x23,6" RC / 23,6"x23,6" RC / 39,4"x39,4" RC

**OUTDOOR:** 60x60x2 RC / 100x100x2 RC  
**OUTDOOR:** 23,6"x 23,6"x0,8" RC / 39,4"x39,4"x0,8" RC

OUTDOOR<sup>2</sup>

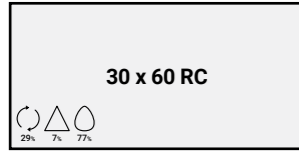

FOSSIL WHITE GIVRÉ CTE1/R10 / B226  
FOSSIL GREY GIVRÉ CTE1/R10 / B226  
FOSSIL DARK GIVRÉ CTE1/R10 / B226

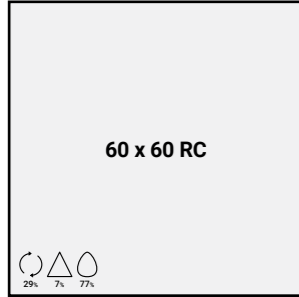

FOSSIL WHITE GIVRÉ CTE1/R10 / B226  
FOSSIL GREY GIVRÉ CTE1/R10 / B226  
FOSSIL DARK GIVRÉ CTE1/R10 / B226



FOSSIL 20 WHITE GIVRÉ CTE3/R11/C / B410  
FOSSIL 20 GREY GIVRÉ CTE3/R11/C / B410  
FOSSIL 20 DARK GIVRÉ CTE3/R11/C / B410

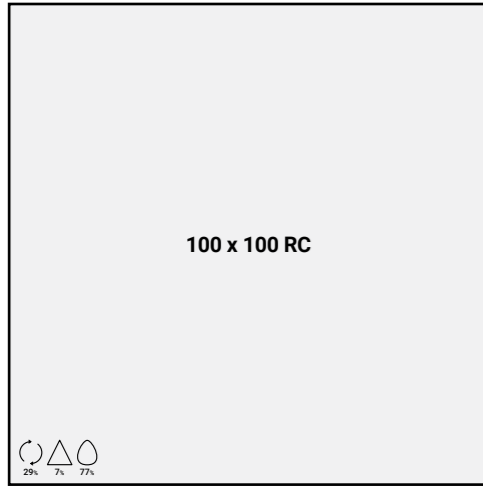

FOSSIL WHITE GIVRÉ CTE1/R10 / B310  
FOSSIL GREY GIVRÉ CTE1/R10 / B310  
FOSSIL DARK GIVRÉ CTE1/R10 / B310

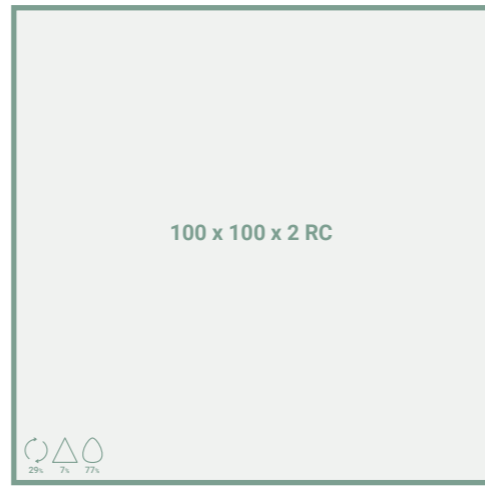

FOSSIL 20 WHITE GIVRÉ CTE3/R11/C / B600  
FOSSIL 20 GREY GIVRÉ CTE3/R11/C / B600  
FOSSIL 20 DARK GIVRÉ CTE3/R11/C / B600

EJEMPLO DE VARIEDAD GRÁFICA  
GRAPHIC VARIETY EXAMPLE

FOSSIL GREY GIVRÉ 60x60 RC  
FOSSIL GREY GIVRÉ 23,6" x 23,6" RC

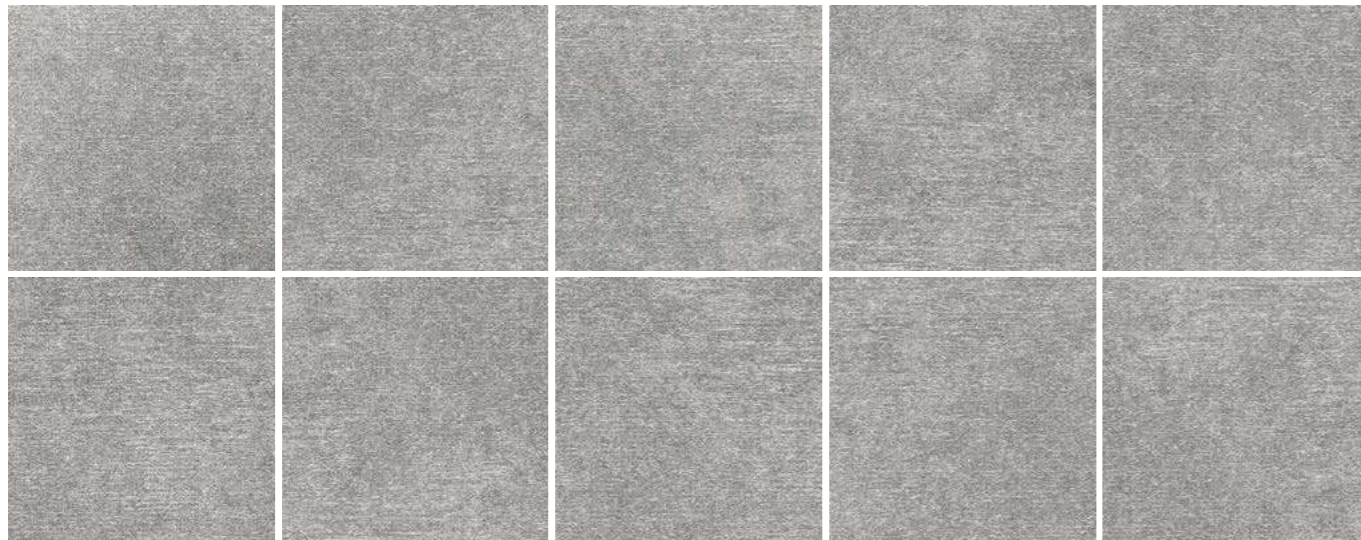

FOSSIL DEC WHITE  
60x60 RC / B226

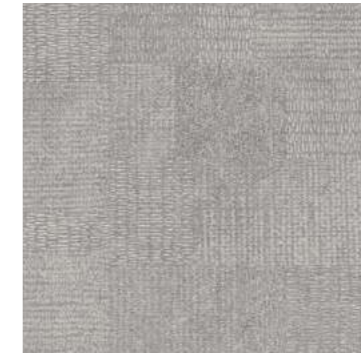

FOSSIL 20 DEC WHITE  
60x60 RC / B410



FOSSIL DEC DARK  
60x60 RC / B226

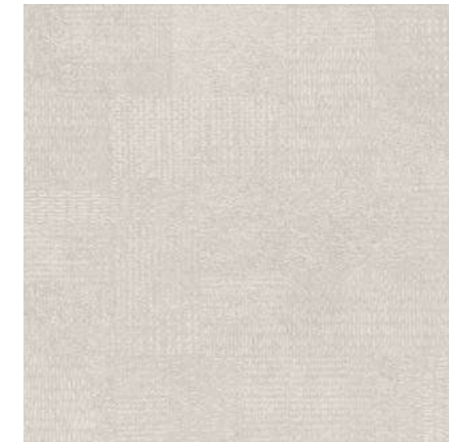

FOSSIL DEC WHITE  
100x100 RC / B310

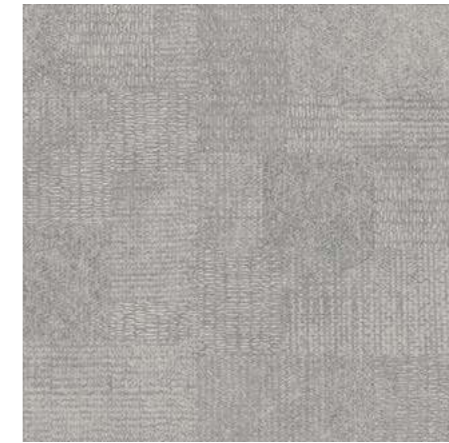

FOSSIL 20 DEC WHITE  
100x100 RC / B600



FOSSIL DEC DARK  
100x100 RC / B310



FOSSIL 20 GREY GIVRÉ 100x100 RC / FOSSIL GREY GIVRÉ 100x100 RC

blanco

perla

grafito

crema

moka

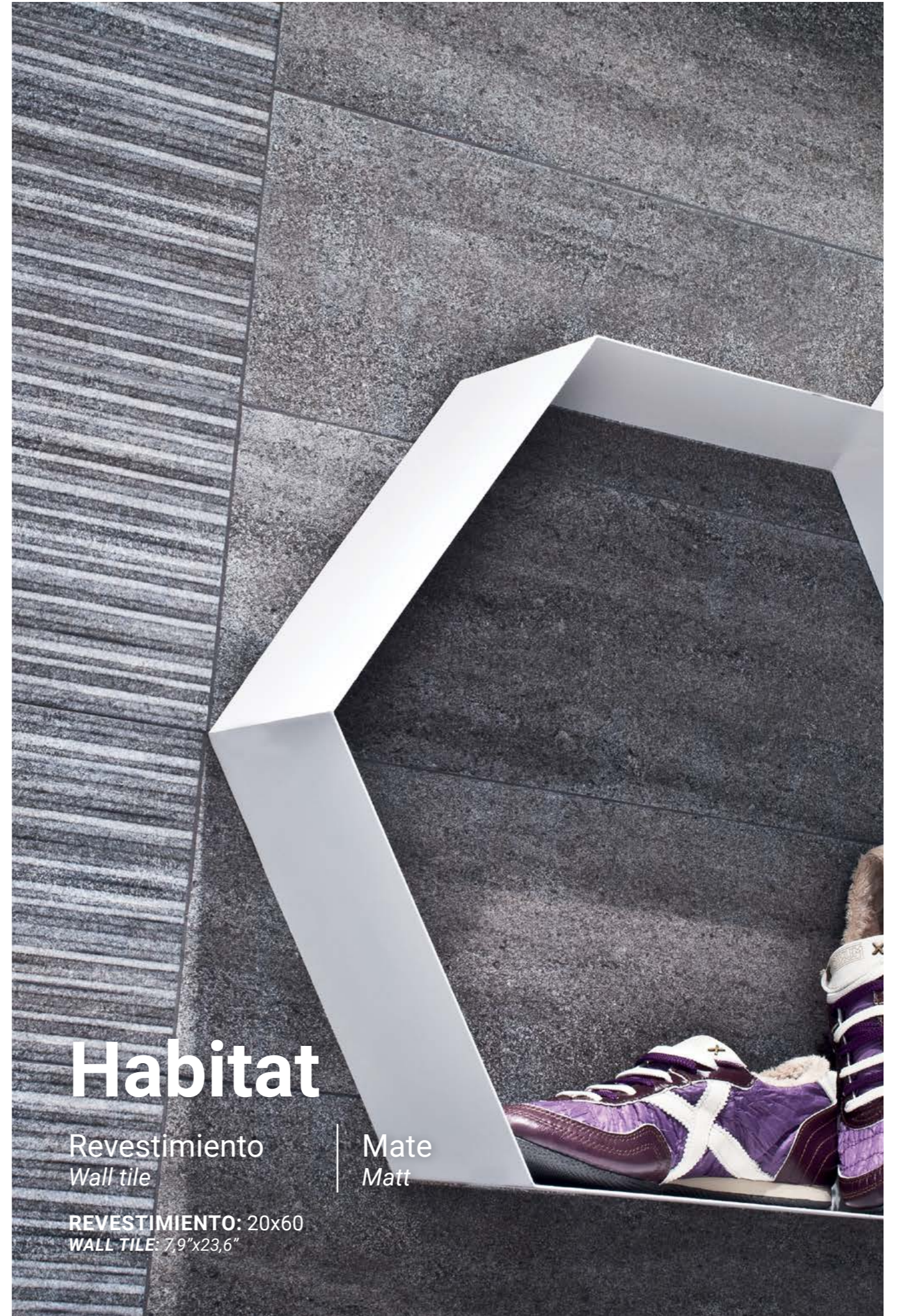

# Habitat

Revestimiento  
Wall tile

Mate  
Matt

REVESTIMIENTO: 20x60  
WALL TILE: 7,9"x23,6"



HABITAT BLANCO / B115  
HABITAT PERLA / B115  
HABITAT GRAFITO / B115  
HABITAT CREMA / B115  
HABITAT MOKA / B115

EJEMPLO DE VARIEDAD GRÁFICA  
GRAPHIC VARIETY EXAMPLE



HABITAT MOKA 20X60  
HABITAT MOKA 7,9"x26,6"



HABITAT-4 BLANCO  
20x60 / B138



HABITAT-4 PERLA  
20x60 / B138



HABITAT-4 GRAFITO  
20x60 / B138



HABITAT-4 CREMA  
20x60 / B138



HABITAT-4 MOKA  
20x60 / B138



HABITAT MOKA 20x60 / HABITAT-4 MOKA 20x60 / HABITAT-2 DEC CREMA 20x60



white

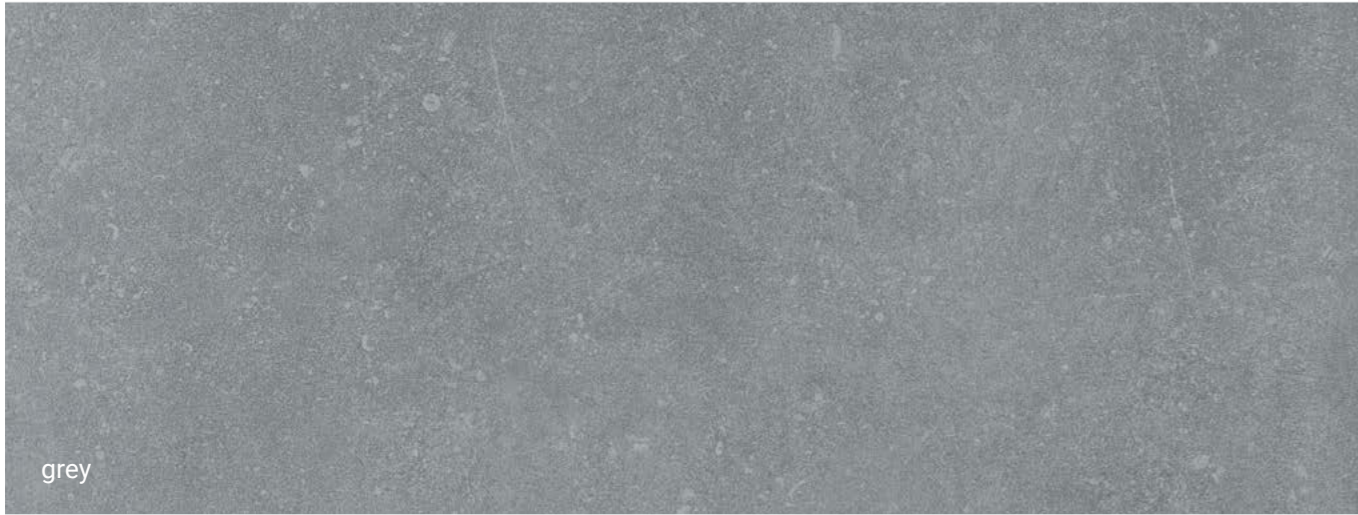

grey

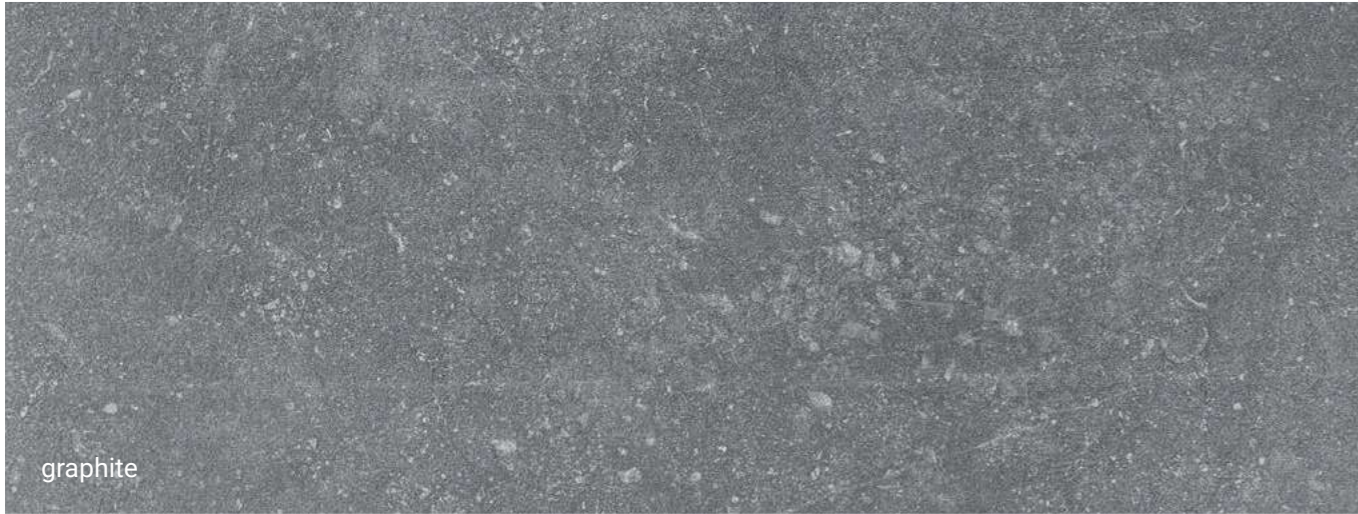

graphite

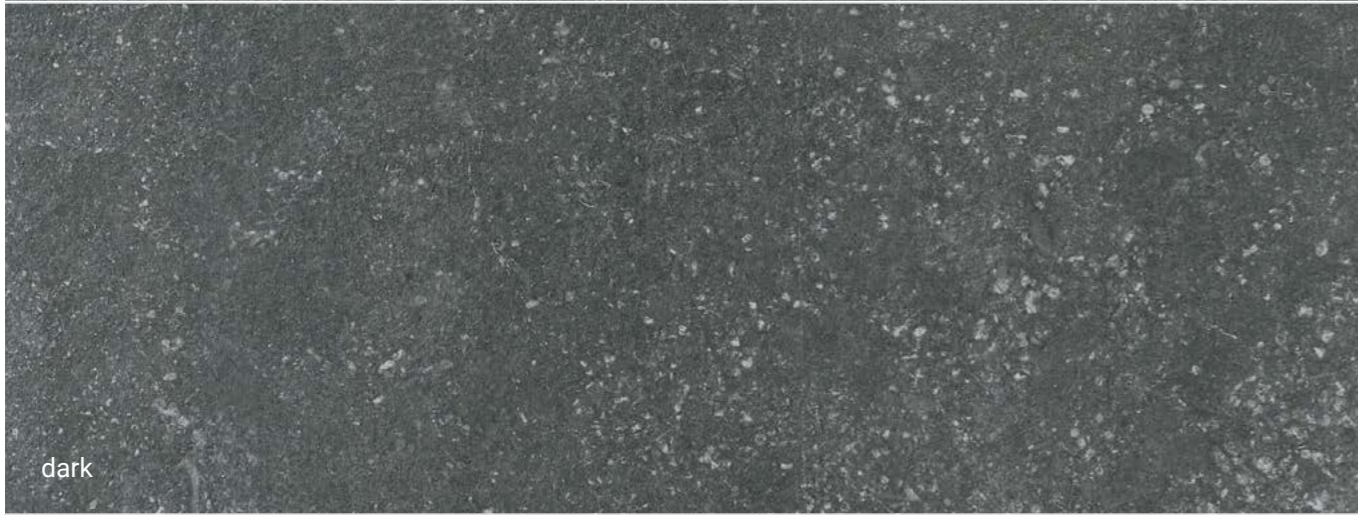

dark

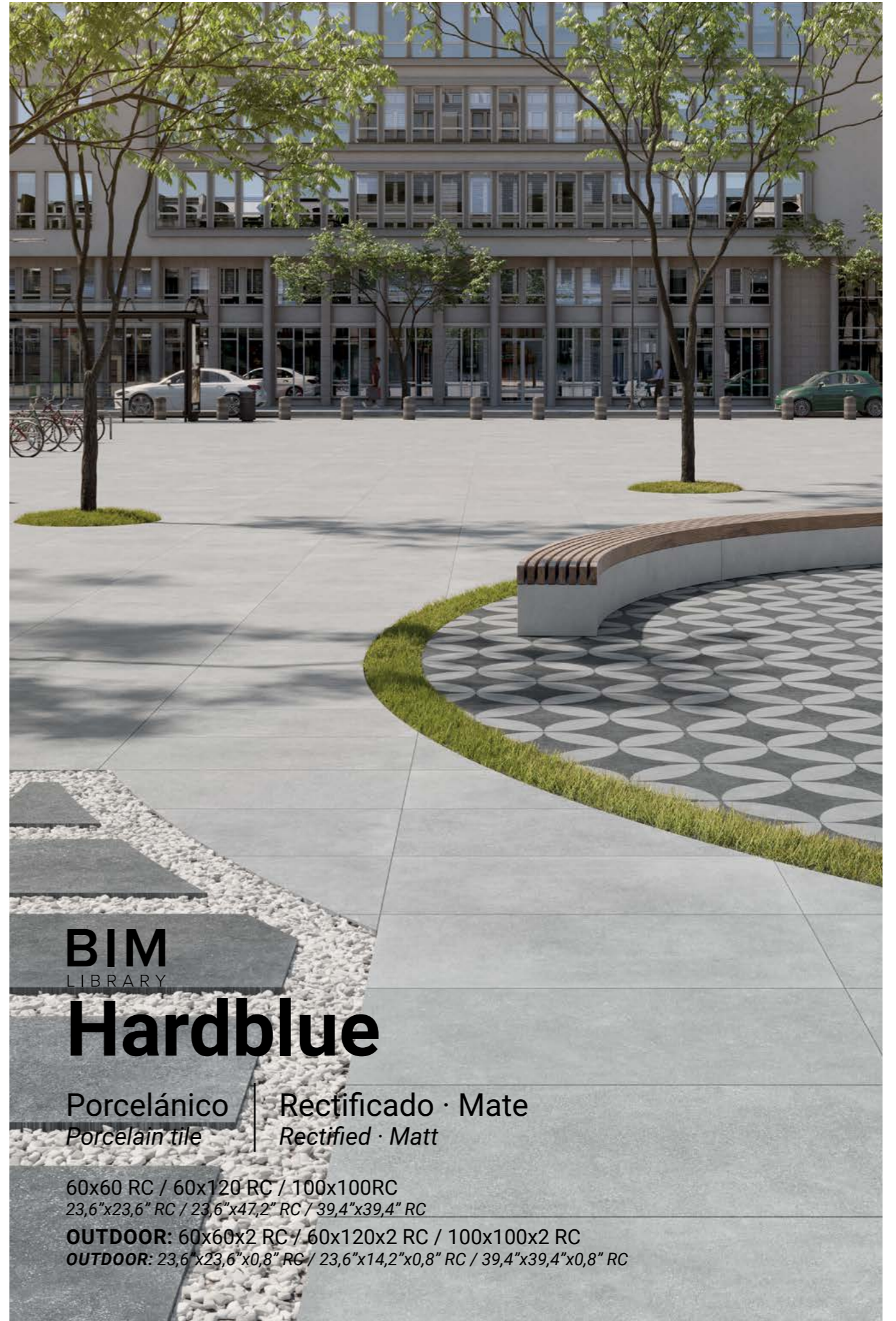

**BIM**  
LIBRARY

# Hardblue

Porcelánico  
*Porcelain tile*

Rectificado · Mate  
*Rectified · Matt*

60x60 RC / 60x120 RC / 100x100RC  
23,6"x23,6" RC / 23,6"x47,2" RC / 39,4"x39,4" RC

**OUTDOOR:** 60x60x2 RC / 60x120x2 RC / 100x100x2 RC  
**OUTDOOR:** 23,6"x23,6"x0,8" RC / 23,6"x14,2"x0,8" RC / 39,4"x39,4"x0,8" RC

OUTDOOR 20<sup>ME</sup>

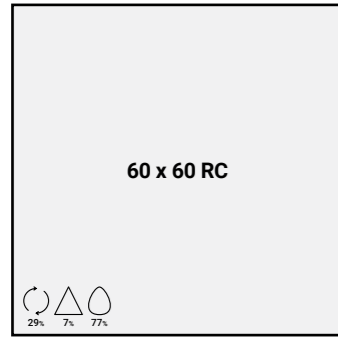

HARDBLUE WHITE CTE1/R10/B / B226  
HARDBLUE GREY CTE1/R10/B / B226  
HARDBLUE GRAPHITE CTE1/R10/B / B226  
HARDBLUE DARK CTE1/R10/B / B226

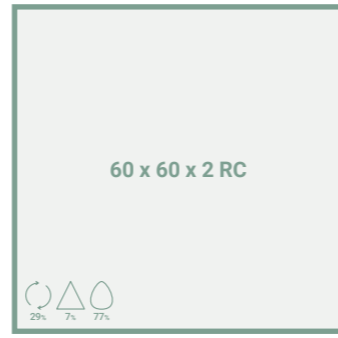

60 x 60 x 2 RC

HARDBLUE WHITE CTE3/R11/C / B410  
HARDBLUE GREY CTE3/R11/C / B410  
HARDBLUE GRAPHITE CTE3/R11/C / B410  
HARDBLUE DARK CTE3/R11/C / B410

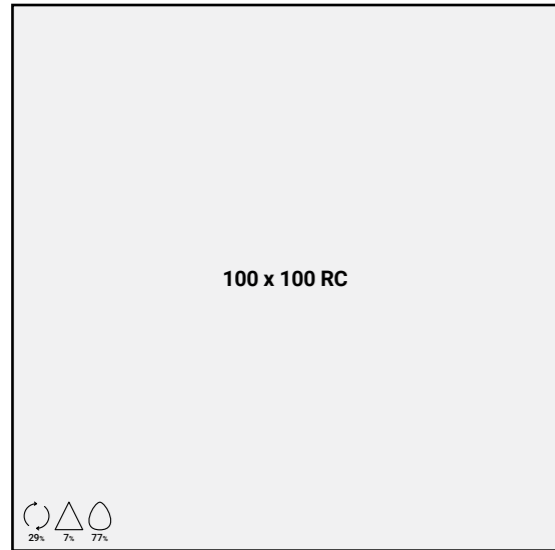

100 x 100 RC

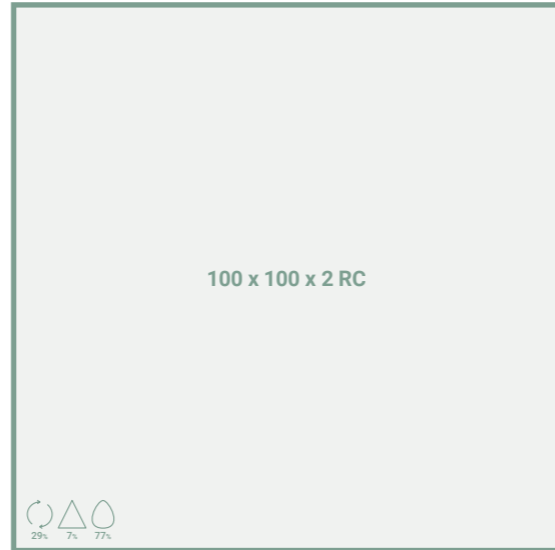

100 x 100 x 2 RC

HARDBLUE WHITE CTE1/R10/B / B310  
HARDBLUE GREY CTE1/R10/B / B310  
HARDBLUE GRAPHITE CTE1/R10/B / B310  
HARDBLUE DARK CTE1/R10/B / B310

HARDBLUE WHITE CTE3/R11/C / B600  
HARDBLUE GREY CTE3/R11/C / B600  
HARDBLUE GRAPHITE CTE3/R11/C / B600  
HARDBLUE DARK CTE3/R11/C / B600

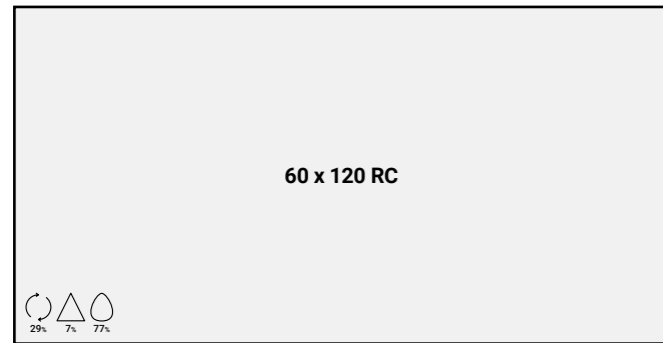

60 x 120 RC



60 x 120 x 2 RC

HARDBLUE WHITE CTE1/R10/B / B310  
HARDBLUE GREY CTE1/R10/B / B310  
HARDBLUE GRAPHITE CTE1/R10/B / B310  
HARDBLUE DARK CTE1/R10/B / B310

HARDBLUE 20 WHITE CTE3/R11/C / B600  
HARDBLUE 20 GREY CTE3/R11/C / B600  
HARDBLUE 20 GRAPHITE CTE3/R11/C / B600  
HARDBLUE 20 DARK CTE3/R11/C / B600

EJEMPLO DE VARIEDAD GRÁFICA  
GRAPHIC VARIETY EXAMPLE

HARDBLUE DARK 60x60 RC  
HARDBLUE DARK 23,6"x23,6" RC

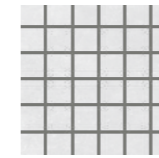

MS HARDBLUE WHITE  
30x30 / C108

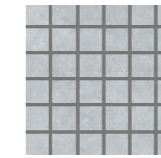

MS HARDBLUE GREY  
30x30 / C108

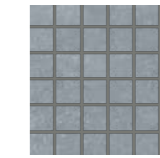

MS HARDBLUE GRAPHITE  
30x30 / C108

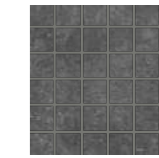

MS HARDBLUE DARK  
30x30 / C108

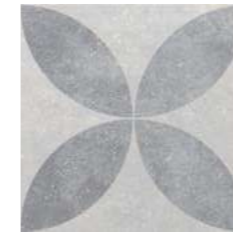

HARDBLUE DEC 1 CTE1/R10/B  
60x60 RC / B226  
HARDBLUE 20 DEC 1 CTE3/R11/C  
60x60 RC / B410

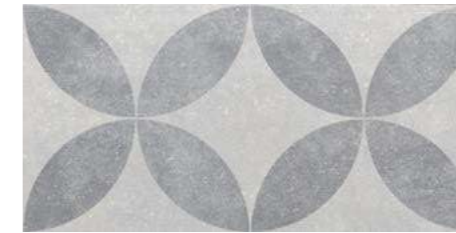

HARDBLUE DEC 1 CTE1/R10/B / 60x120 RC / B310  
HARDBLUE 20 DEC 1 CTE3/R11/C / 60x120 RC / B600



HARDBLUE DEC 1 CTE1/R10/B / 100x100 RC / B310  
HARDBLUE 20 DEC 1 CTE3/R11/C / 100x100 RC / B600

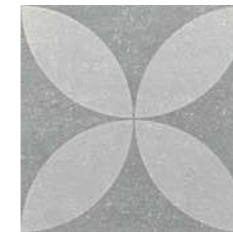

HARDBLUE DEC 2 CTE1/R10/B  
60x60 RC / B226  
HARDBLUE 20 DEC 2 CTE3/R11/C  
60x60 RC / B410



HARDBLUE DEC 2 CTE1/R10/B / 60x120 RC / B310  
HARDBLUE 20 DEC 2 CTE3/R11/C / 60x120 RC / B600



HARDBLUE DEC 2 CTE1/R10/B / 100x100 RC / B310  
HARDBLUE 20 DEC 2 CTE3/R11/C / 100x100 RC / B600

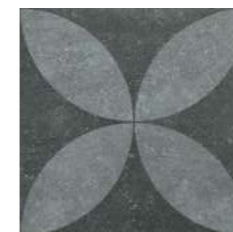

HARDBLUE DEC 3 CTE1/R10/B  
60x60 RC / B226  
HARDBLUE 20 DEC 3 CTE3/R11/C  
60x60 RC / B410

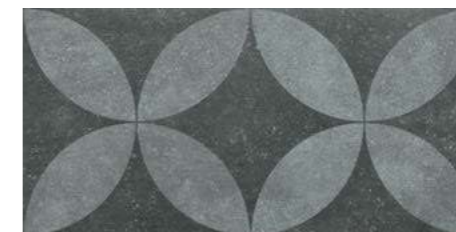

HARDBLUE DEC 3 CTE1/R10/B / 60x120 RC / B310  
HARDBLUE 20 DEC 3 CTE3/R11/C / 60x120 RC / B600



HARDBLUE DEC 3 CTE1/R10/B / 100x100 RC / B310  
HARDBLUE 20 DEC 3 CTE3/R11/C / 100x100 RC / B600



white



grey



calcite



taupe



# Kalos

Porcelánico  
*Porcelain tile*

Rectificado · Mate  
*Rectified · Matt*

60x60 RC  
23,6"x23,6" RC

**PASTA BLANCA:** 33x100 RC  
**WHITE BODY:** 12,9"x39,4" RC





33 x 100 RC



PASTA BLANCA  
WHITE BODY COLOR

KALOS WHITE / B208  
KALOS GREY / B208  
KALOS CALCITE / B208  
KALOS TAUPE / B208

60 x 60 RC

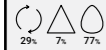

KALOS WHITE / B226  
KALOS GREY / B226  
KALOS CALCITE / B226  
KALOS TAUPE / B226

EJEMPLO DE VARIEDAD GRÁFICA  
GRAPHIC VARIETY EXAMPLE



KALOS GREY 60x60 RC  
KALOS GREY 23,6"x23,6" RC



KALOS-DEC CLEI WHITE A  
33x100 RC / C395



KALOS-DEC CLEI WHITE B  
33x100 RC / C395



KALOS-DEC CLEI CALCITE A  
33x100 RC / C395



KALOS-DEC CLEI CALCITE B  
33x100 RC / C395



KALOS-DEC COLD  
33x100 RC / B230



KALOS-DEC WARM  
33x100 RC / B230



KALOS-REL WHITE  
33x100 RC / B230



KALOS-REL CALCITE  
33x100 RC / B230

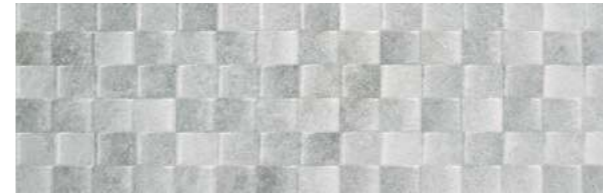

KALOS-REL GREY  
33x100 RC / B230



KALOS-REL TAUPE  
33x100 RC / B230



KALOS WHITE 33x100 RC / KALOS WHITE 60x60 RC



grey



beige



# Kinesis

Porcelánico  
Porcelain tile

Mate  
Matt

31,6x60,8  
12,4"x23,9"

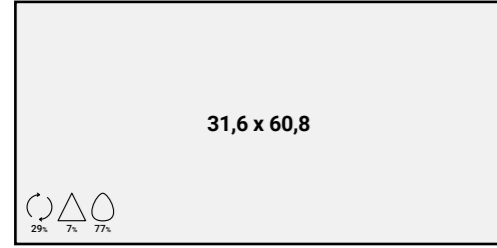

KINESIS GREY CTE1/R9 / B186  
KINESIS BEIGE CTE1/R9 / B186

VARIEDAD GRÁFICA  
GRAPHIC VARIETY

KINESIS GREY 31,6x60,8  
KINESIS GREY 12,4"x23,9"



KINESIS REL GREY  
31,6x60,8 RC / B205

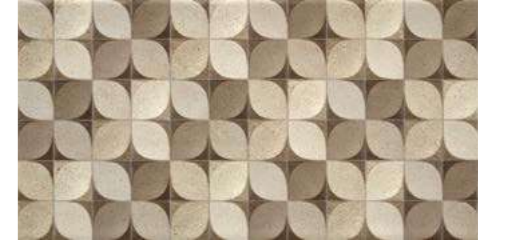

KINESIS REL BEIGE  
31,6x60,8 RC / B205



KINESIS BEIGE 31,6x60,8 / KINESIS REL BEIGE 31,6x60,8



white



grey



calcite



# Kore

Porcelánico  
Porcelain tile

Mate  
Matt

47,2x47,2  
18,6"x18,6"

REVESTIMIENTO: 20x60  
WALL TILE: 7,9"x23,6"



KORE WHITE / B115  
KORE GREY / B115  
KORE CALCITE / B115

REVESTIMIENTO  
WALL TILE

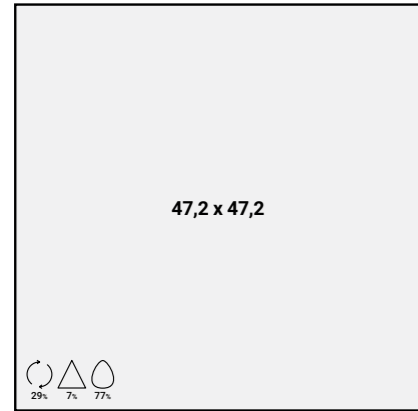

KORE WHITE / B186  
KORE GREY / B186  
KORE CALCITE / B186

PAVIMENTO COORDINADO  
COORDINATED FLOOR TILE



KORE WHITE CTE1/R9/A  
47,2x47,2 RC / B186



KORE GREY CTE1/R9/A  
47,2x47,2 RC / B186



KORE CALCITE CTE1/R9/A  
47,2x47,2 RC / B186

EJEMPLO DE VARIEDAD GRÁFICA  
GRAPHIC VARIETY EXAMPLE

KORE GREY 20x60  
KORE GREY 7,9"x23,6"



KORE REL WHITE / 20x60 / B138



KORE REL GREY / 20x60 / B138



KORE REL CALCITE / 20x60 / B138



ARCTIC DECOR / 20x60 / C186



KORE DEC COLD / 20x60 / B138



KORE DEC WARM / 20x60 / B138

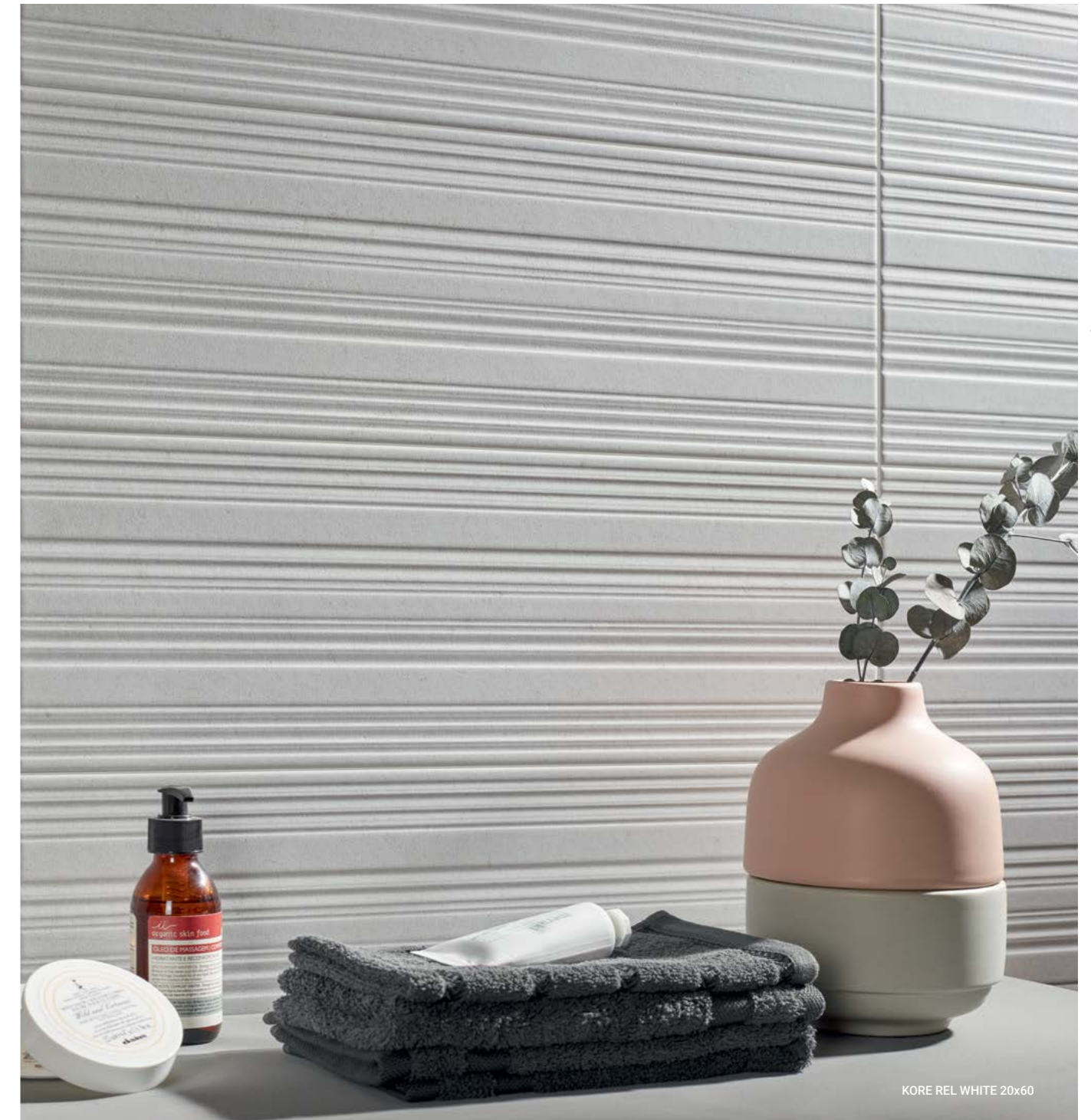

KORE REL WHITE 20x60



white



grey



cream



taupe

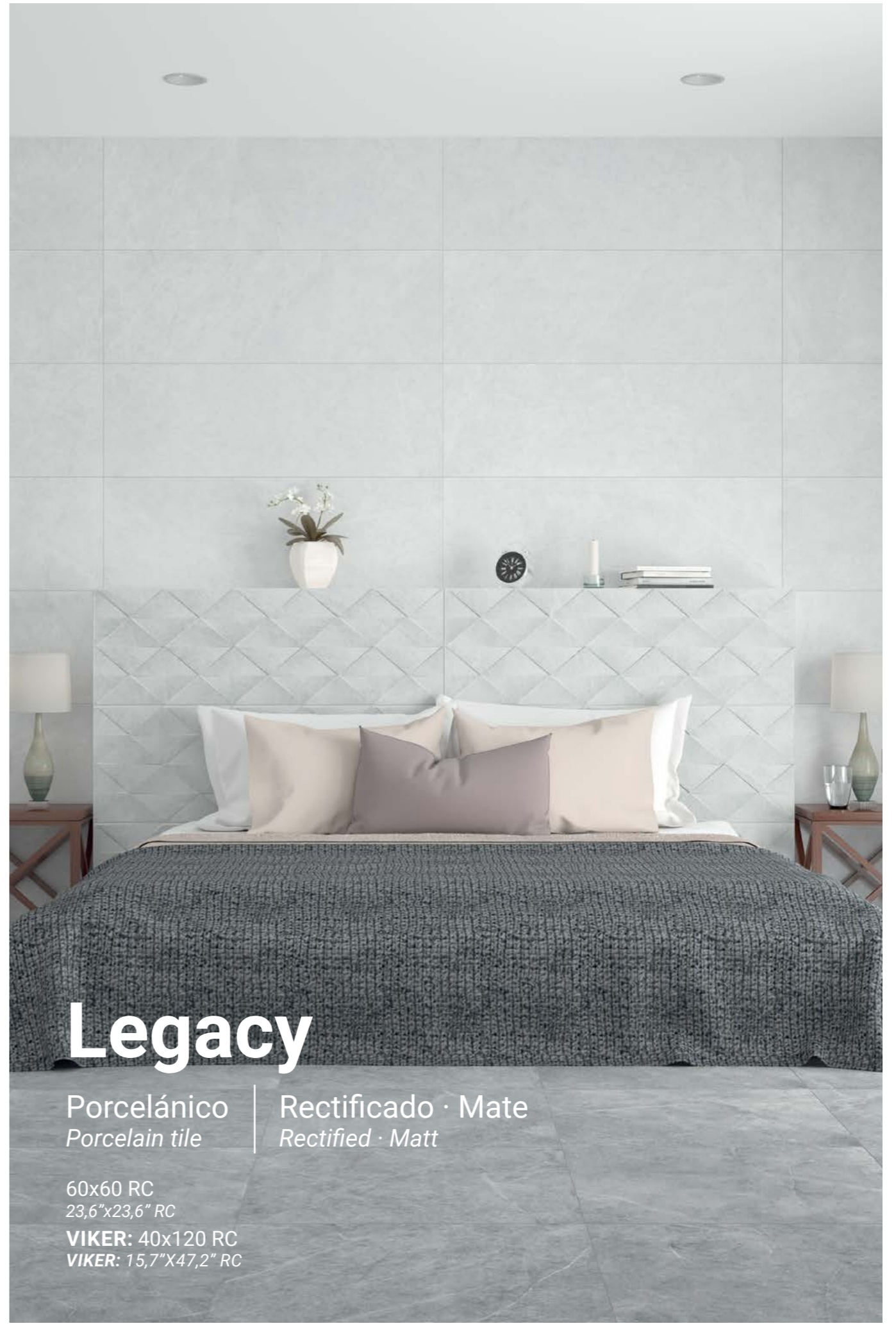

# Legacy

Porcelánico  
*Porcelain tile*

Rectificado · Mate  
*Rectified · Matt*

60x60 RC  
23,6"x23,6" RC

VIKER: 40x120 RC  
VIKER: 15,7"x47,2" RC

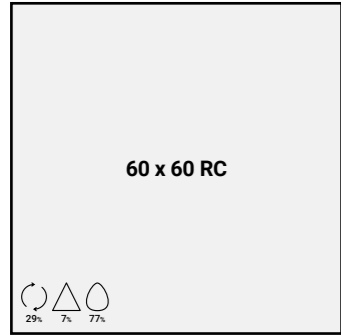

LEGACY WHITE / B226  
LEGACY GREY / B226  
LEGACY CREAM / B226  
LEGACY TAUPE / B226



PORCELÁNICO  
PORCELAIN TILE  
LEGACY 7 WHITE / B288  
LEGACY 7 GREY / B288  
LEGACY 7 CREAM / B288  
LEGACY 7 TAUPE / B288



LEGACY-REL 7 WHITE  
40x120 RC / B310



LEGACY-REL 7 GREY  
40x120 RC / B310



LEGACY-REL 7 CREAM  
40x120 RC / B310



LEGACY-REL 7 TAUPE  
40x120 RC / B310

EJEMPLO DE VARIEDAD GRÁFICA  
GRAPHIC VARIETY EXAMPLE

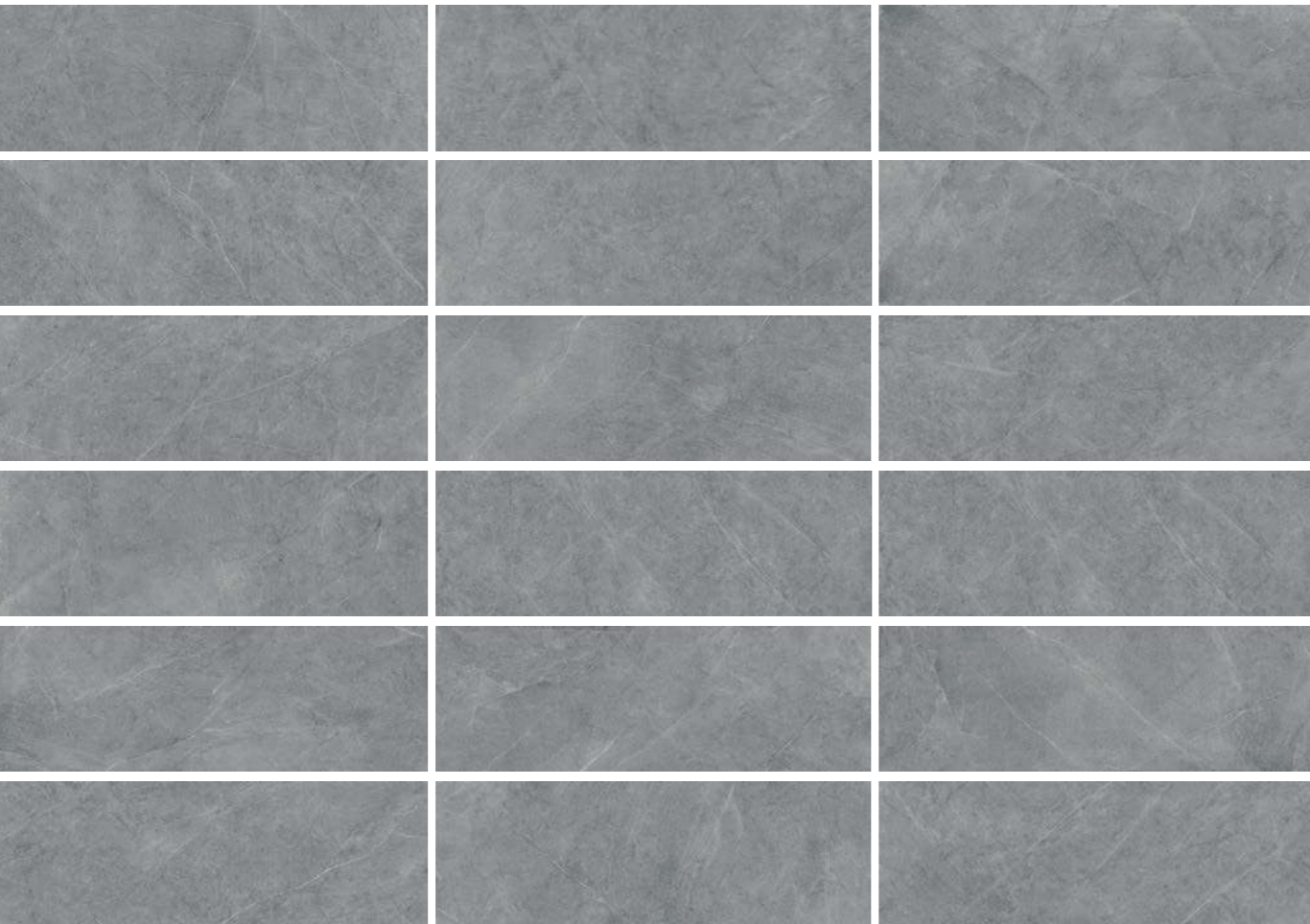

LEGACY GREY 40X120 RC  
LEGACY GREY 15,7"x47,2" RC



LEGACY 7 GREY 40x120 RC / LEGACY-REL 7 GREY 40x120 RC / LEGACY 7 GREY 60x60 RC



white

pearl

grey

black

calcita

vison



# Livermore

Porcelánico  
Porcelain tile

Rectificado · Mate · Antideslizante  
Rectified · Matt · Anti-slip

31,6x60,8 / 47,2x47,2 / 60x60 RC / 60x120 RC / 75x75 RC / 100x100 RC  
12,4"x23,9" / 18,6"x18,6" / 23,6"x 23,6" RC / 23,6"x47,2" RC / 29,5"x29,5" RC / 39,4"x39,4" RC

REVESTIMIENTO: 20x60  
WALL TILE: 7,9"x23,6"

OUTDOOR: 60x60x2 RC / 60x120x2 RC / 100x100x2 RC  
OUTDOOR: 23,6"x23,6"x0,8" RC / 23,6"x47,2"x0,8" RC / 39,4"x39,4"x0,8" RC



47,2 x 47,2

29% 7% 77%

LIVERMORE WHITE / B186  
LIVERMORE PEARL / B186  
LIVERMORE BLACK / B186  
LIVERMORE CALCITA / B186

LIVERMORE WHITE / B115  
LIVERMORE SMOKE / B115  
LIVERMORE ALMOND / B115

20 x 60  
REVESTIMIENTO  
WALL TILE

32% 14% 75%

31,6 x 60,8

29% 7% 77%

LIVERMORE WHITE CTE3/R11/C / B186  
LIVERMORE PEARL CTE3/R11/C / B186  
LIVERMORE BLACK CTE3/R11/C / B186  
LIVERMORE CALCITA CTE3/R11/C / B186

60 x 60 RC

29% 7% 77%

LIVERMORE WHITE CTE2/R10 / B226  
LIVERMORE WHITE CTE3/R11/C / B226  
LIVERMORE PEARL CTE2/R10 / B226  
LIVERMORE GREY CTE2/R10 / B226  
LIVERMORE BLACK CTE2/R10 / B226  
LIVERMORE BLACK CTE3/R11/C / B226  
LIVERMORE CALCITA CTE2/R10 / B226  
LIVERMORE VISON CTE2/R10 / B226

174

STONE

UPEC  
excepto white  
except white

75 x 75 RC

29% 7% 77%

LIVERMORE WHITE CTE2/R10 / B273  
LIVERMORE PEARL CTE2/R10 / B273  
LIVERMORE GREY CTE2/R10 / B273  
LIVERMORE BLACK CTE2/R10 / B273  
LIVERMORE CALCITA CTE2/R10 / B273  
LIVERMORE VISON CTE2/R10 / B273

LIVERMORE 20 WHITE CTE3/R11/C / B410  
LIVERMORE 20 PEARL CTE3/R11/C / B410  
LIVERMORE 20 GREY CTE3/R11/C / B410  
LIVERMORE 20 BLACK CTE3/R11/C / B410  
LIVERMORE 20 CALCITA CTE3/R11/C / B410  
LIVERMORE 20 VISON CTE3/R11/C / B410

60 x 60 x 2 RC

29% 7% 77%

60 x 120 RC

29% 7% 77%

LIVERMORE WHITE CTE2/R10 / B310  
LIVERMORE PEARL CTE2/R10 / B310  
LIVERMORE GREY CTE2/R10 / B310  
LIVERMORE BLACK CTE2/R10 / B310  
LIVERMORE CALCITA CTE2/R10 / B310  
LIVERMORE VISON CTE2/R10 / B310

LIVERMORE 20 WHITE CTE3/R11/C / B600  
LIVERMORE 20 PEARL CTE3/R11/C / B600  
LIVERMORE 20 GREY CTE3/R11/C / B600  
LIVERMORE 20 BLACK CTE3/R11/C / B600  
LIVERMORE 20 CALCITA CTE3/R11/C / B600  
LIVERMORE 20 VISON CTE3/R11/C / B600

60 x 120 x 2 RC

29% 7% 77%

100 x 100 RC

29% 7% 77%

LIVERMORE WHITE CTE2/R10 / B310  
LIVERMORE PEARL CTE2/R10 / B310  
LIVERMORE GREY CTE2/R10 / B310  
LIVERMORE BLACK CTE2/R10 / B310  
LIVERMORE CALCITA CTE2/R10 / B310  
LIVERMORE VISON CTE2/R10 / B310

LIVERMORE 20 WHITE CTE3/R11/C / B600  
LIVERMORE 20 PEARL CTE3/R11/C / B600  
LIVERMORE 20 GREY CTE3/R11/C / B600  
LIVERMORE 20 BLACK CTE3/R11/C / B600  
LIVERMORE 20 CALCITA CTE3/R11/C / B600  
LIVERMORE 20 VISON CTE3/R11/C / B600

100 x 100 x 2 RC

29% 7% 77%

OUTDOOR

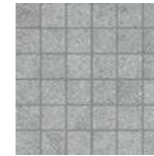

MS LIVERMORE PEARL  
30x30 / C83

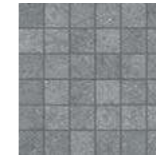

MS LIVERMORE GREY  
30x30 / C83

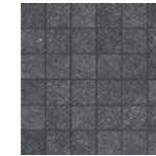

MS LIVERMORE BLACK  
30x30 / C83



MS LIVERMORE CALCITA  
30x30 / C83



MS LIVERMORE VISON  
30x30 / C83

EJEMPLO DE VARIEDAD GRÁFICA  
GRAPHIC VARIETY EXAMPLE

LIVERMORE PEARL 60x120 RC  
LIVERMORE PEARL 23,6"x47,2"

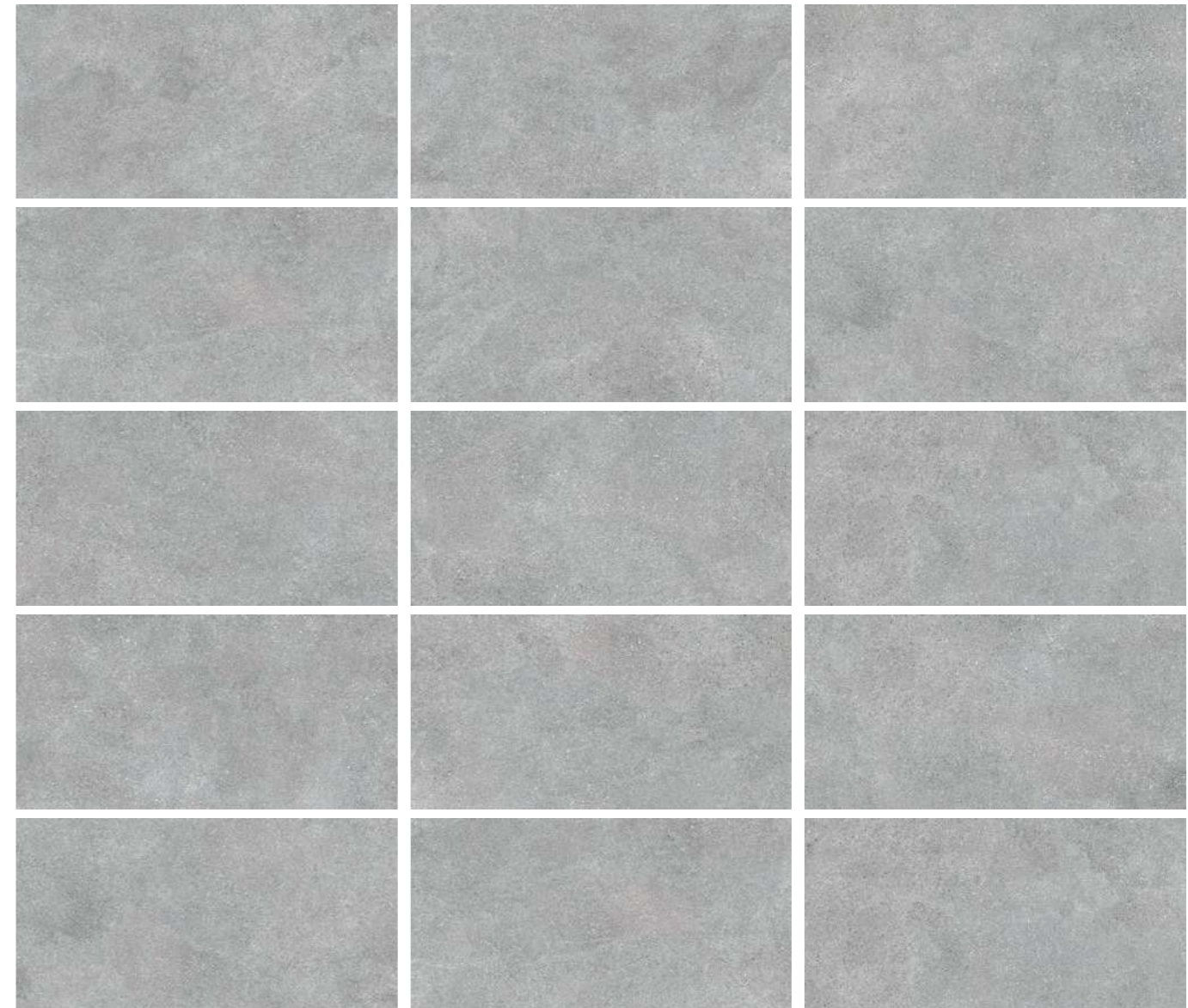



20x60  
7,9"x23,6"

white



20x60  
7,9"x23,6"

smoke



20x60  
7,9"x23,6"

almond

COMPLEMENTOS  
ACCESORIES



LIVERMORE-11 TETRIS WHITE  
20x60 / B138



LIVERMORE-11 TETRIS SMOKE  
20x60 / B138



LIVERMORE-11 TETRIS ALMOND  
20x60 / B138



LIVERMORE ALMOND 20x60 / LIVERMORE 11 TETRIS ALMOND 20x60



white



grey



beige



# Lume

Porcelánico  
Porcelain tile

Mate  
Matt

60x60 RC  
23,6"x23,6" RC

**PASTA BLANCA:** 25x75  
**WHITE BODY:** 9,8"x29,5"



LUME WHITE / B149  
LUME GREY / B149  
LUME BEIGE / B149

PASTA BLANCA  
WHITE BODY COLOR

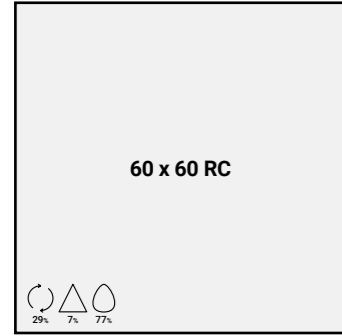

LUME WHITE CTE2/R10/B / B226  
LUME GREY CTE2/R10/B / B226  
LUME BEIGE CTE2/R10/B / B226

60 x 60 RC

PAVIMENTO COORDINADO  
COORDINATED FLOOR TILE



LUME WHITE  
60x60 / B226



LUME GREY  
60x60 / B226



LUME BEIGE  
60x60 / B226

EJEMPLO DE VARIEDAD GRÁFICA  
GRAPHIC VARIETY EXAMPLE



LUME WHITE 25x75  
LUME WHITE 9,8"x29,5"



LUME DEC WARM / 25x75 / B166

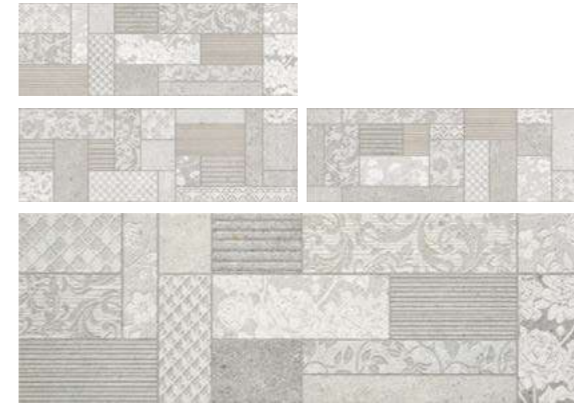

LUME DEC COLD / 25x75 / B166

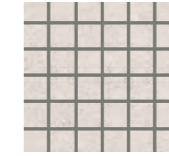

MS LUME WHITE  
30x30 / C065

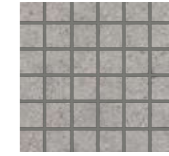

MS LUME GREY  
30x30 / C065



MS LUME BEIGE  
30x30 / C065



LUME REL WHITE / 25x75 / B166



LUME REL GREY / 25x75 / B166



LUME REL BEIGE / 25x75 / B166



LUME BEIGE 25x75 / LUME REL BEIGE 25x75



blanco

gris

antracita

marfil

beige



# Materia

Porcelánico  
*Porcelain tile*

Rectificado · Mate · Antideslizante  
*Rectified · Matt · Anti-slip*

31,6x60,8 / 60x60 / 75x75 RC  
12,4"x23,9" / 23,6"x23,6" / 29,5"x29,5" RC

**OUTDOOR:** 60x60x2 RC / 75x75x2 RC  
**OUTDOOR:** 23,6"x23,6"x0,8" RC / 29,5"x29,5"x0,8" RC

**PASTA BLANCA:** 33x100 RC  
**WHITE BODY:** 12,9"x39,4" RC





MATERIA MARFIL / B208  
MATERIA BEIGE / B208  
MATERIA BLANCO / B208  
MATERIA GRIS / B208  
MATERIA ANTRACITA / B208

29% 7% 77%  
PASTA BLANCA  
WHITE BODY

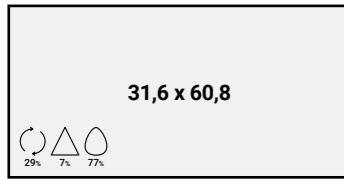

MATERIA MARFIL CTE1/R9 / B186  
MATERIA MARFIL CTE3/R11/C / B186  
MATERIA BEIGE CTE1/R9 / B186  
MATERIA BEIGE CTE3/R11/C / B186  
MATERIA BLANCO CTE1/R9 / B186  
MATERIA BLANCO CTE3/R11/C / B186  
MATERIA GRIS CTE1/R9 / B186  
MATERIA GRIS CTE3/R11/C / B186  
MATERIA ANTRACITA CTE1/R9 / B186  
MATERIA ANTRACITA CTE3/R11/C / B186

29% 7% 77%



MATERIA MARFIL CTE1/R9 / B208  
MATERIA BEIGE CTE1/R9 / B208  
MATERIA BLANCO CTE1/R9 / B208  
MATERIA GRIS CTE1/R9 / B208  
MATERIA ANTRACITA CTE1/R9 / B208

29% 7% 77%



MATERIA 20 MARFIL CTE3/R11/C / B410  
MATERIA 20 BEIGE CTE3/R11/C / B410  
MATERIA 20 BLANCO CTE3/R11/C / B410  
MATERIA 20 GRIS CTE3/R11/C / B410  
MATERIA 20 ANTRACITA CTE3/R11/C / B410

29% 7% 77%

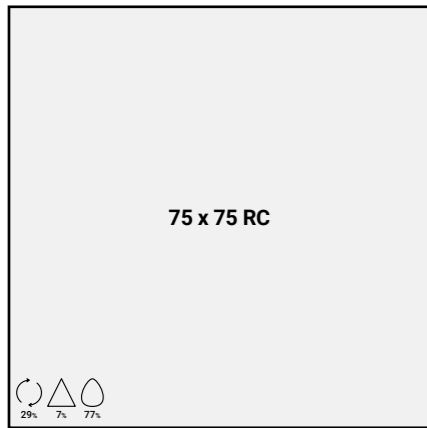

MATERIA MARFIL CTE1/R9 / B273  
MATERIA BEIGE CTE1/R9 / B273  
MATERIA BLANCO CTE1/R9 / B273  
MATERIA GRIS CTE1/R9 / B273  
MATERIA ANTRACITA CTE1/R9 / B273

29% 7% 77%



MATERIA 20 MARFIL CTE3/R11/C / B524  
MATERIA 20 GRIS CTE3/R11/C / B524  
MATERIA 20 ANTRACITA CTE3/R11/C / B524

29% 7% 77%

EJEMPLO DE VARIEDAD GRÁFICA  
GRAPHIC VARIETY EXAMPLE

MATERIA GRIS 60x60  
MATERIA GRIS 23,6"x23,6"



MATERIA BRICK MARFIL  
30x30 / C115



MATERIA BRICK BEIGE  
30x30 / C115



MATERIA BRICK BLANCO  
30x30 / C115



MATERIA BRICK GRIS  
30x30 / C115



MATERIA BRICK ANTRACITA  
30x30 / C115



MATERIA REL BLANCO  
33x100 RC / B230



MATERIA REL GRIS  
33x100 RC / B230



MATERIA GRIS 33x100 RC / MATERIA REL GRIS 33x100 / MATERIA GRIS 60x60



white



grey



dark

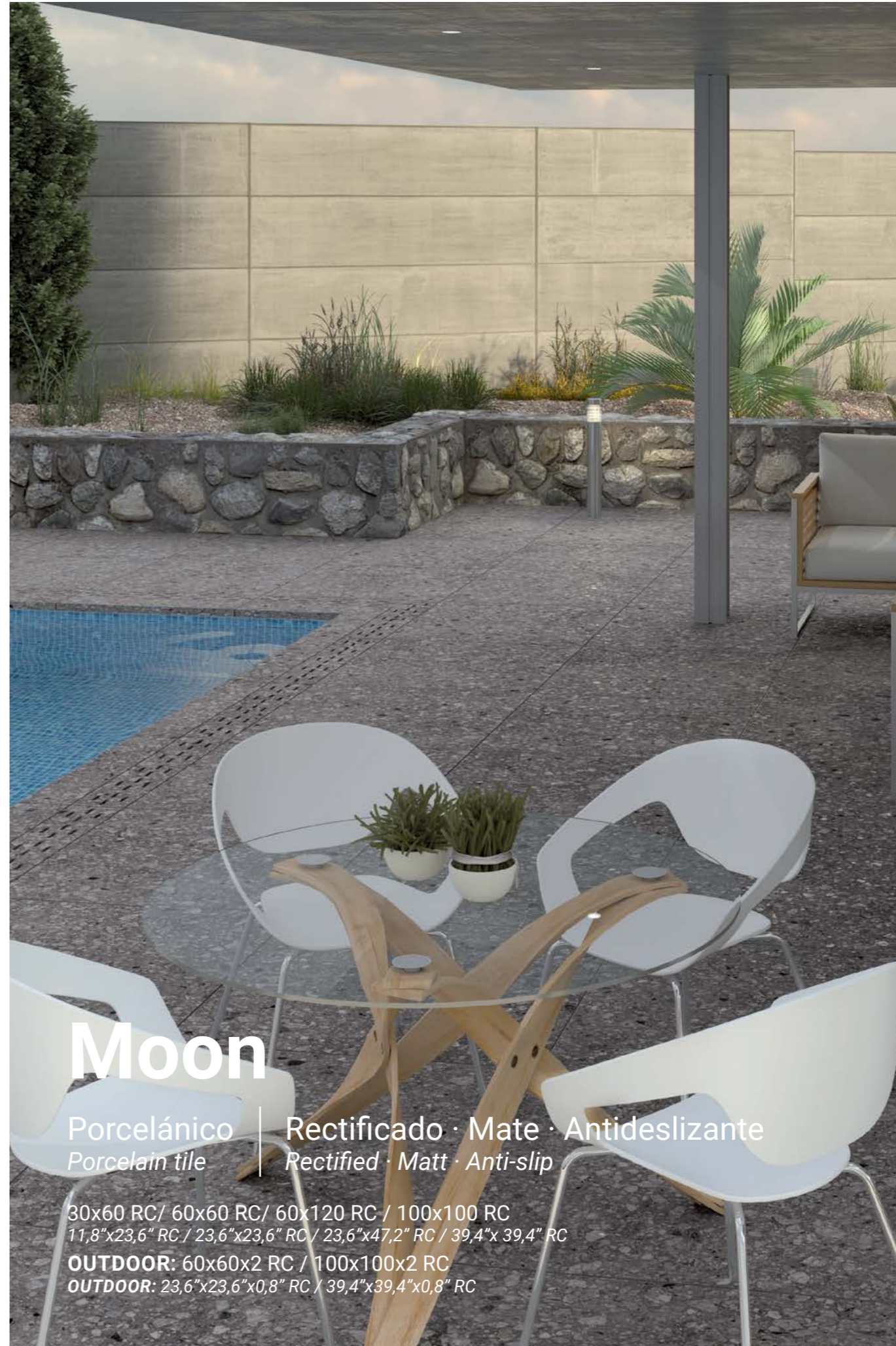

# Moon

Porcelánico  
Porcelain tile

Rectificado · Mate · Antideslizante  
Rectified · Matt · Anti-slip

30x60 RC / 60x60 RC / 60x120 RC / 100x100 RC  
11,8"x23,6" RC / 23,6"x23,6" RC / 23,6"x47,2" RC / 39,4"x 39,4" RC

**OUTDOOR:** 60x60x2 RC / 100x100x2 RC  
**OUTDOOR:** 23,6"x23,6"x0,8" RC / 39,4"x39,4"x0,8" RC

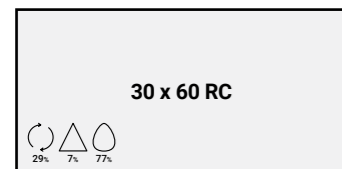

MOON WHITE CTE1 / B226  
MOON GREY CTE1 / B226  
MOON DARK CTE1 / B226

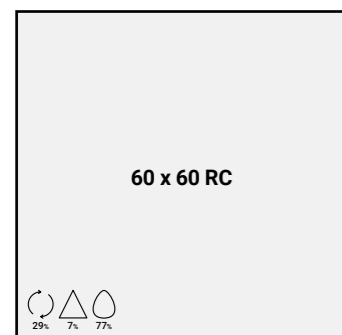

MOON WHITE CTE1 / B226  
MOON GREY CTE1 / B226  
MOON GREY CTE3/R11/C / B226  
MOON DARK CTE1 / B226  
MOON DARK CTE3/R11/C / B226

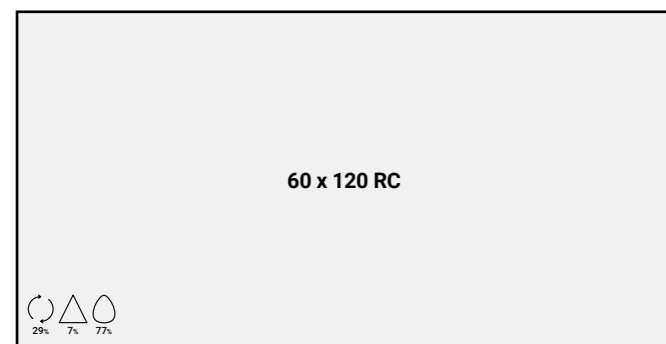

60 x 120 RC

MOON WHITE / B310  
MOON GREY / B310  
MOON DARK / B310



60 x 60 x 2 RC

MOON 20 WHITE CTE3/R11/C / B410  
MOON 20 GREY CTE3/R11/C / B410  
MOON 20 DARK CTE3/R11/C / B410

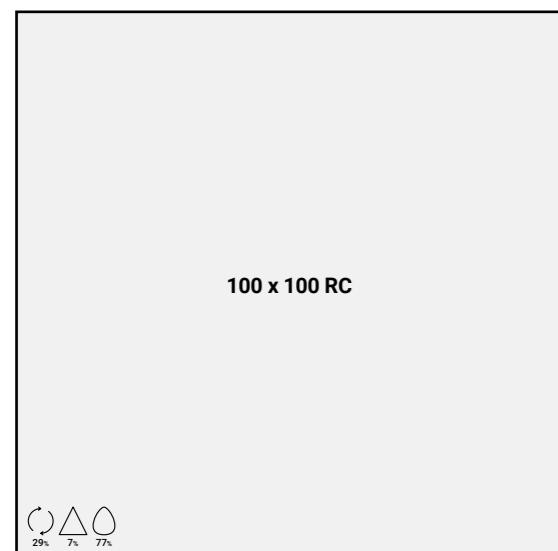

100 x 100 RC

MOON WHITE CTE1 / B310  
MOON GREY CTE1 / B310  
MOON GREY CTE3/R11/C / B310  
MOON DARK CTE1 / B310  
MOON DARK CTE3/R11/C / B310

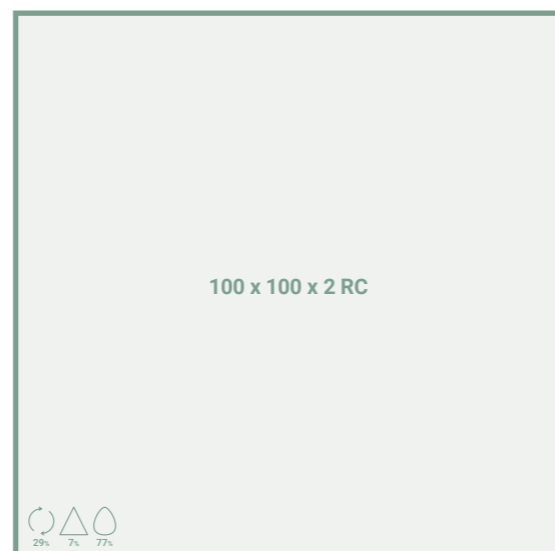

100 x 100 x 2 RC

MOON 20 WHITE CTE3/R11/C / B600  
MOON 20 GREY CTE3/R11/C / B600  
MOON 20 DARK CTE3/R11/C / B600

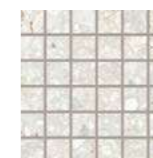

MS MOON WHITE  
30x30 / C103



MS MOON GREY  
30x30 / C103



MS MOON DARK  
30x30 / C103



MOON GREY 100x100 RC / MOON GREY 60x120 RC



white

grey

cream



# Muse

Porcelánico  
*Porcelain tile*

Rectificado · Mate  
*Rectified · Matt*

60x60 RC  
23,6"x23,6" RC

**VIKER:** 40x120 RC  
**VIKER:** 15,7"x47,2" RC

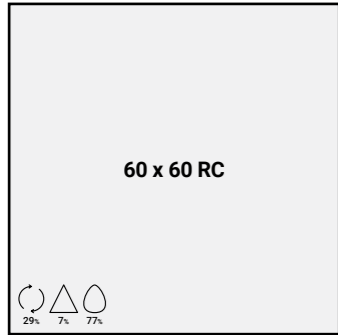

MUSE WHITE / B226  
MUSE GREY / B226  
MUSE CREAM / B226



PORCELÁNICO  
PORCELAIN TILE

MUSE 7 WHITE / B288  
MUSE 7 GREY / B288  
MUSE 7 CREAM / B288

EJEMPLO DE VARIEDAD GRÁFICA  
GRAPHIC VARIETY EXAMPLE

MUSE 7 GREY 40X120 RC  
MUSE 7 GREY 15,7"x47,2" RC

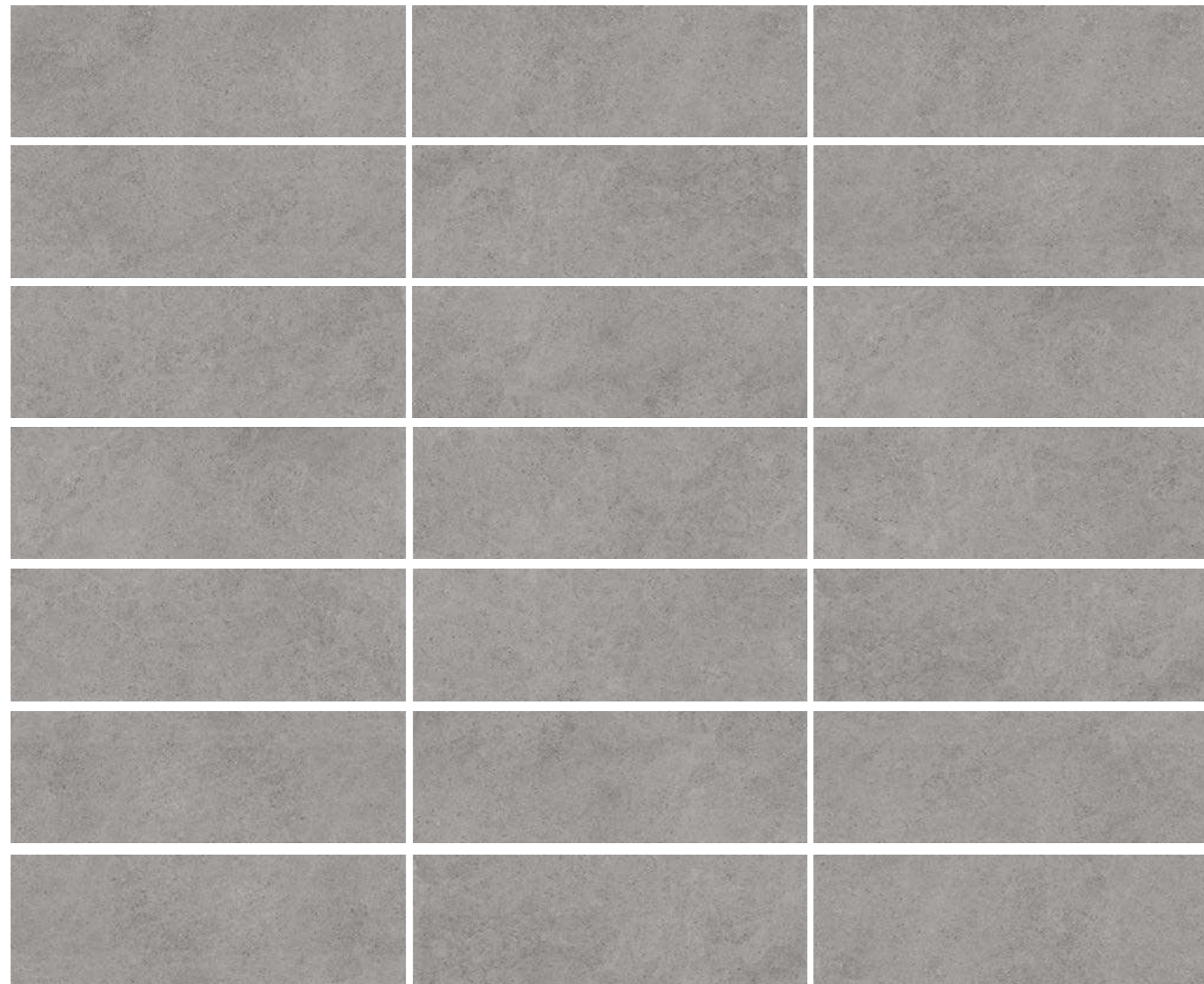

COMPLEMENTOS  
ACCESSORIES



MUSE 7 REL WHITE  
40x120 RC / B310



MUSE 7 REL GREY  
40x120 RC / B310



MUSE 7 REL CREAM  
40x120 RC / B310



MUSE GREY 60x60 RC



white



grey



bone

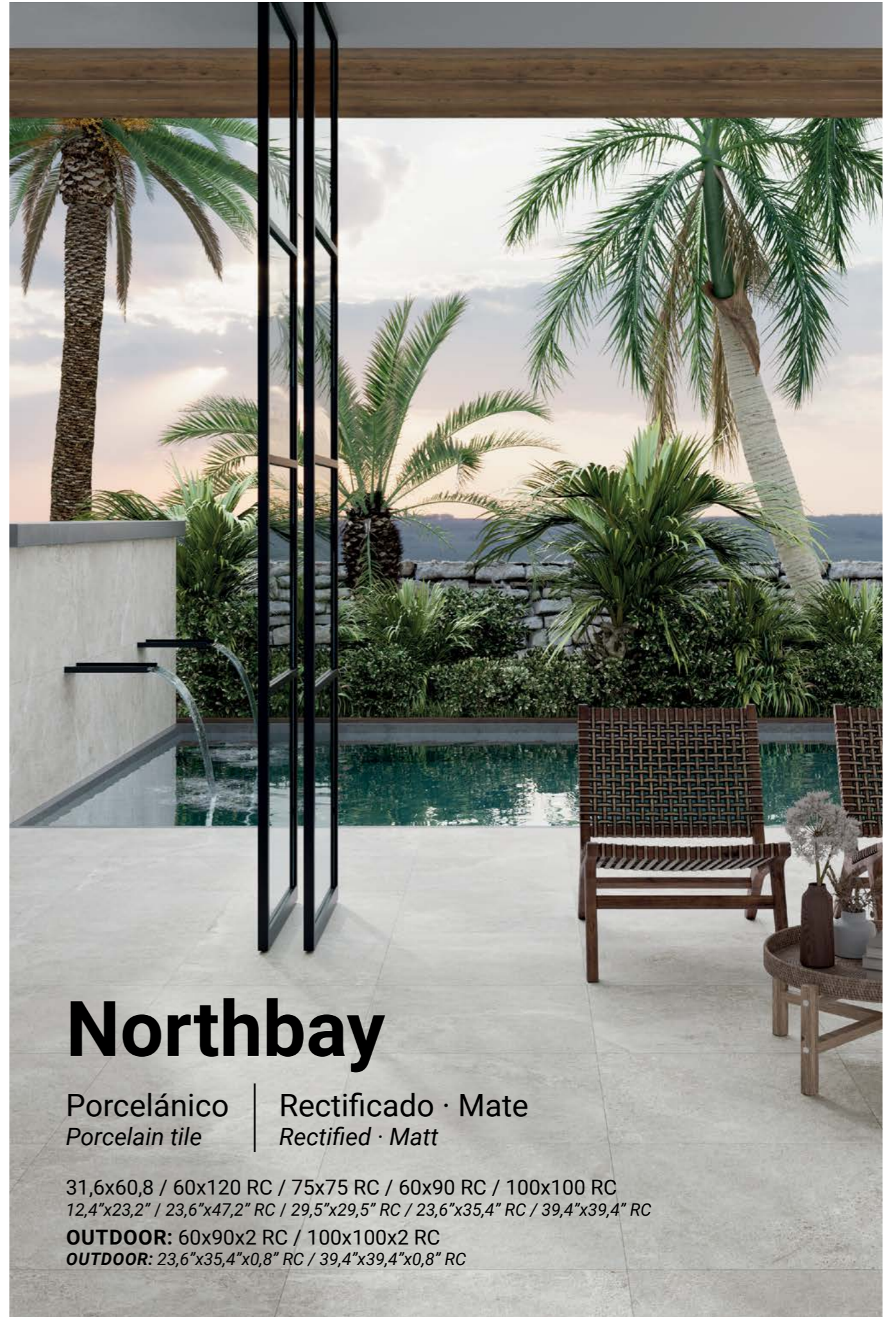

# Northbay

Porcelánico | Rectificado · Mate  
*Porcelain tile* | *Rectified · Matt*

31,6x60,8 / 60x120 RC / 75x75 RC / 60x90 RC / 100x100 RC  
12,4"x23,2" / 23,6"x47,2" RC / 29,5"x29,5" RC / 23,6"x35,4" RC / 39,4"x39,4" RC

**OUTDOOR:** 60x90x2 RC / 100x100x2 RC  
**OUTDOOR:** 23,6"x35,4"x0,8" RC / 39,4"x39,4"x0,8" RC

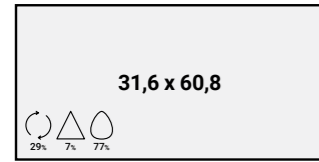

NORTHBAY WHITE / B186  
NORTHBAY BONE / B186  
NORTHBAY GREY / B186

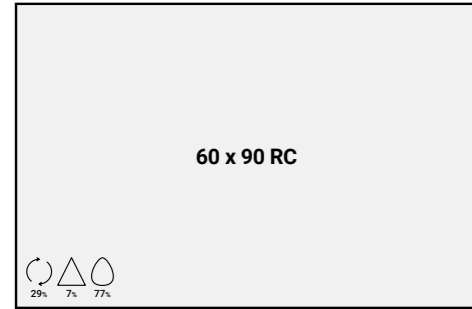

NORTHBAY WHITE / B273  
NORTHBAY BONE / B273  
NORTHBAY GREY / B273

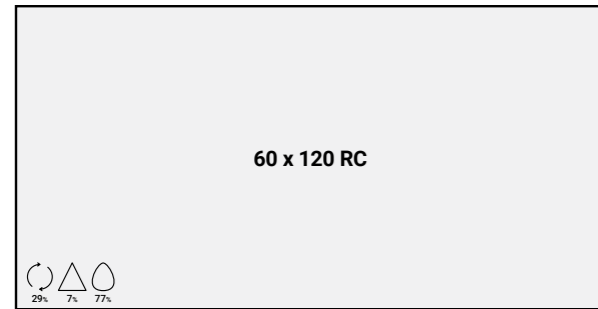

NORTHBAY WHITE / B310  
NORTHBAY BONE / B310  
NORTHBAY GREY / B310

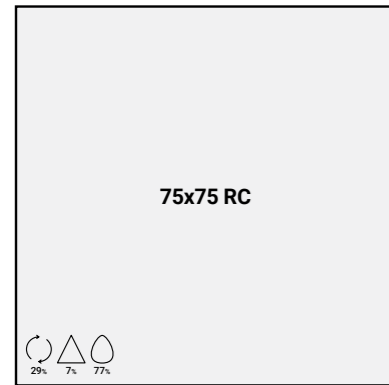

NORTHBAY WHITE / B273  
NORTHBAY BONE / B273  
NORTHBAY GREY / B273



60 x 90 x 2 RC

NORTHBAY 20 WHITE CTE3/R11/C/ B524  
NORTHBAY 20 BONE CTE3/R11/C/ B524  
NORTHBAY 20 GREY CTE3/R11/C / B524

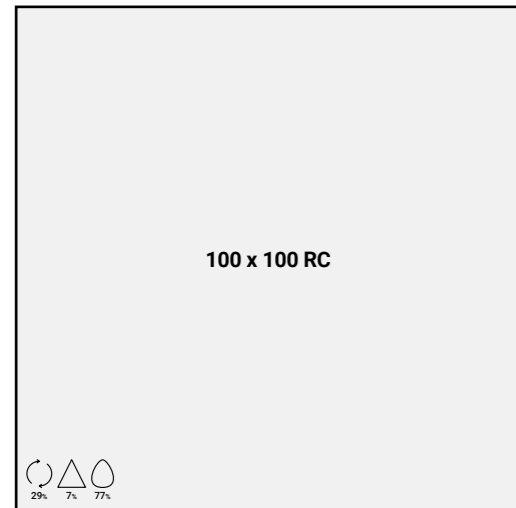

100 x 100 RC

NORTHBAY WHITE / B310  
NORTHBAY BONE / B310  
NORTHBAY GREY / B310

NORTHBAY 20 WHITE CTE3/R11/C/ B600  
NORTHBAY 20 BONE CTE3/R11/C/ B600  
NORTHBAY 20 GREY CTE3/R11/C / B600

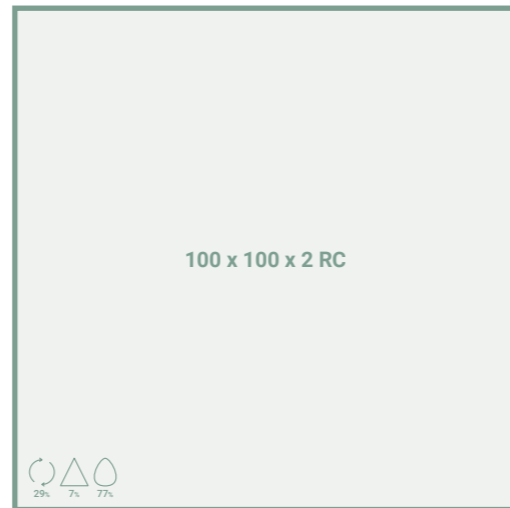

100 x 100 x 2 RC



NORTHBAY-REL WHITE  
31,6x60,8 / B205



NORTHBAY-REL GREY  
31,6x60,8 / B205



NORTHBAY-REL BONE  
31,6x60,8 / B205

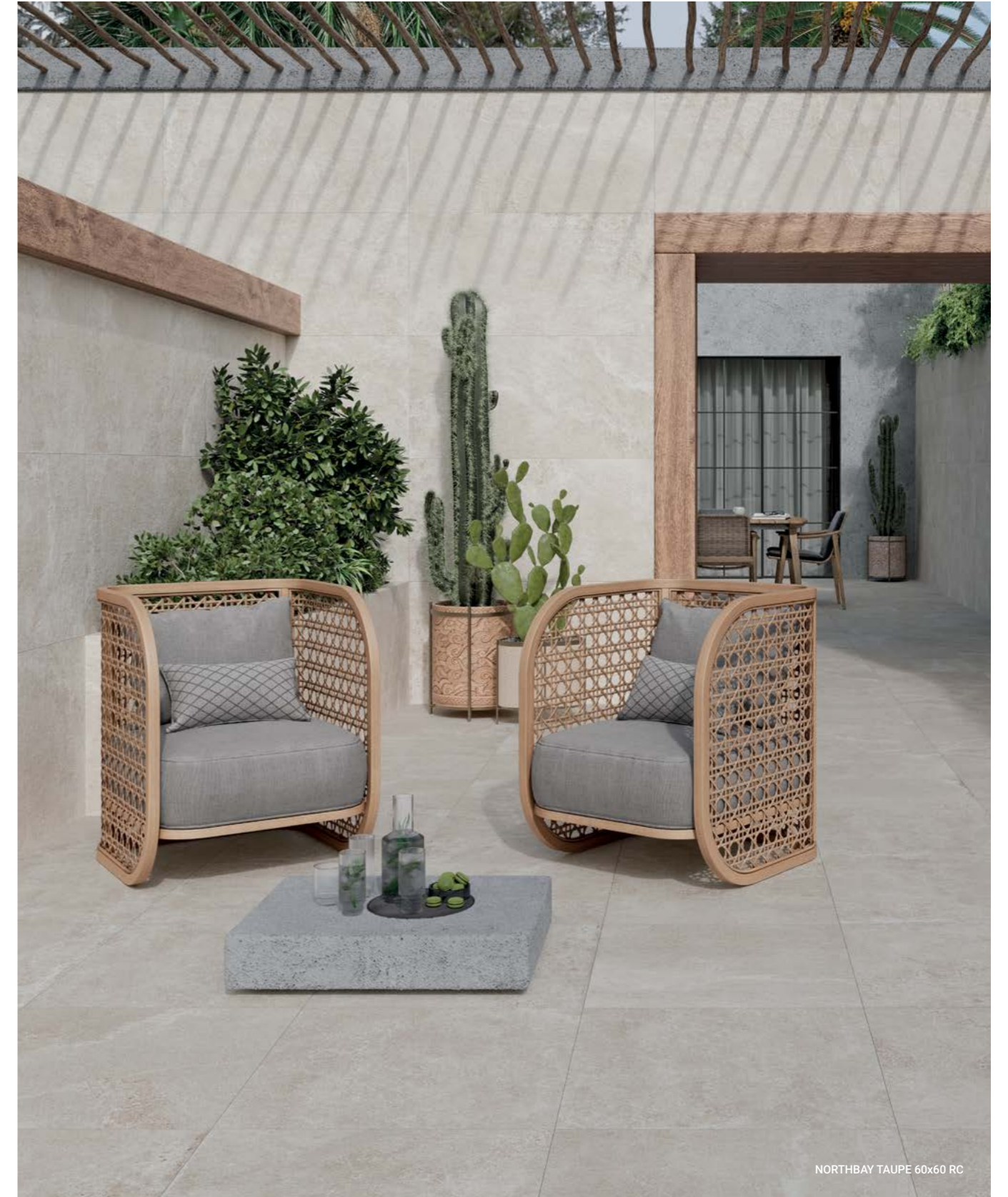

NORTHBAY TAUPE 60x60 RC

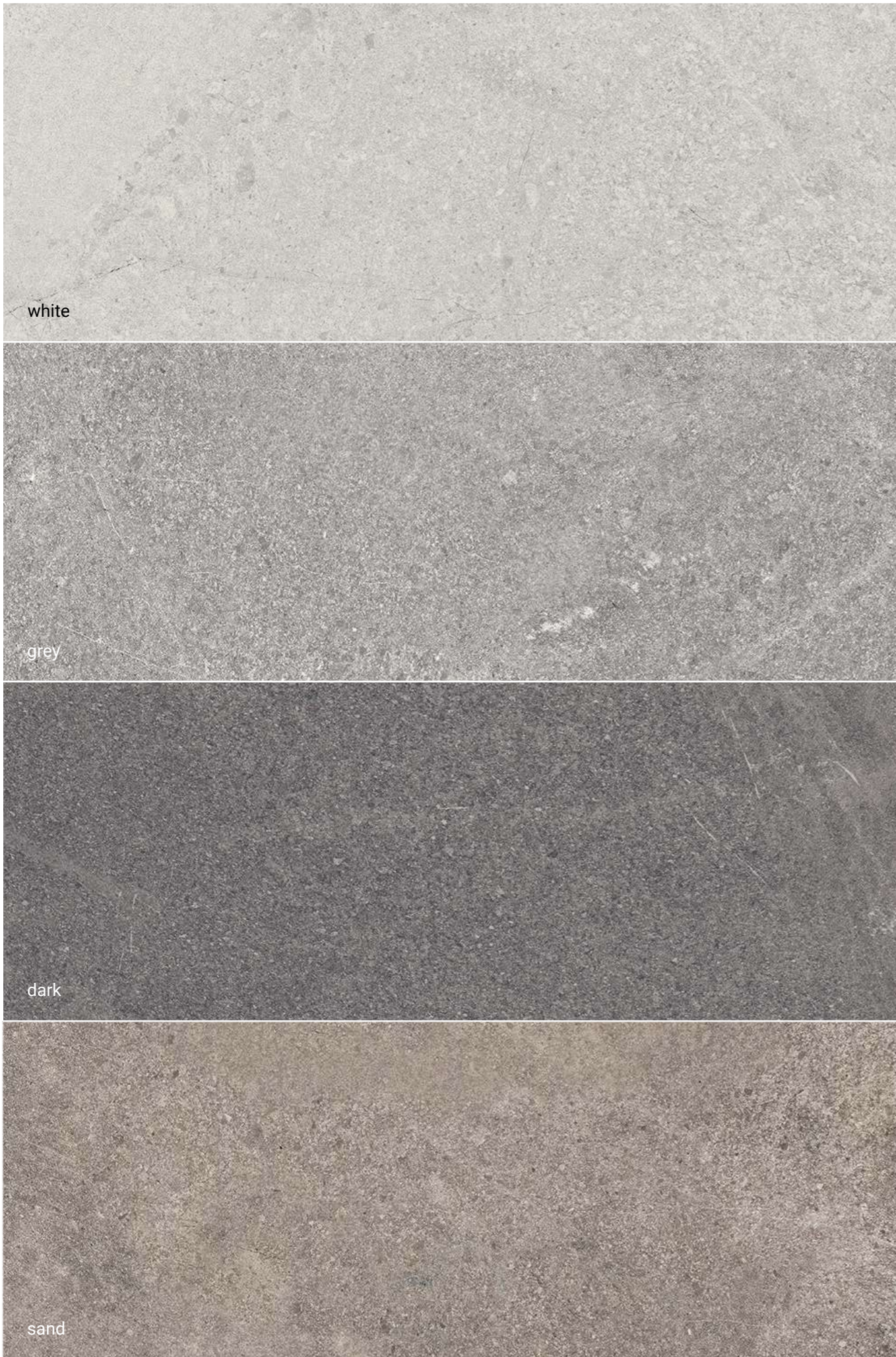

BIM  
LIBRARY

# Salisbury

Porcelánico  
Porcelain tile

Rectificado · Mate · Lapado · Antideslizante  
Rectified · Matt · Lapatto · Anti-slip

30x60 RC / 31,6x60,8 / 60x60 RC / 60x120 RC / 100x100 RC  
11,8"x23,6" RC / 12,4"x23,9" / 23,6"x23,6" RC / 23,6"x47,2" RC / 39,4"x39,4" RC

VIKER: 40x120 RC  
VIKER: 15,7"x47,2" RC

OUTDOOR: 60x60x2 RC / 60x90x2 RC / 60x120x2 RC / 100x100x2 RC  
OUTDOOR: 23,6"x23,6"x0,8" RC / 23,6"x35,42"x0,8" RC / 23,6"x47,2"x0,8" RC / 39,4"x39,4"x0,8" RC

OUTDOOR



SALISBURY 7 WHITE / B288  
SALISBURY 7 GREY / B288  
SALISBURY 7 DARK / B288  
SALISBURY 7 SAND / B288

PORCELÁNICO  
PORCELAIN TILE

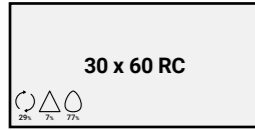

SALISBURY WHITE CTE2/R10 / B226  
SALISBURY GREY CTE2/R10 / B226  
SALISBURY DARK CTE2/R10 / B226  
SALISBURY SAND CTE2/R10 / B226

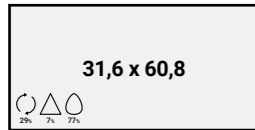

SALISBURY WHITE CTE2/R10 / B186  
SALISBURY WHITE CTE3/R11/C / B186  
SALISBURY GREY CTE2/R10 / B186  
SALISBURY GREY CTE3/R11/C / B186  
SALISBURY DARK CTE2/R10 / B186  
SALISBURY DARK CTE3/R11/C / B186  
SALISBURY SAND CTE2/R10 / B186  
SALISBURY SAND CTE3/R11/C / B186

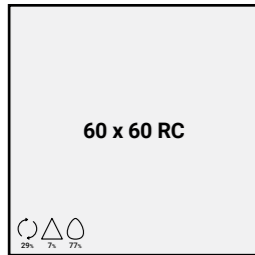

SALISBURY WHITE CTE2/R10 / B226  
SALISBURY WHITE CTE3/R11/C / B226  
SALISBURY GREY CTE2/R10 / B226  
SALISBURY GREY CTE3/R11/C / B226  
SALISBURY DARK CTE2/R10 / B226  
SALISBURY DARK CTE3/R11/C / B226  
SALISBURY SAND CTE2/R10 / B226  
SALISBURY SAND CTE3/R11/C / B226

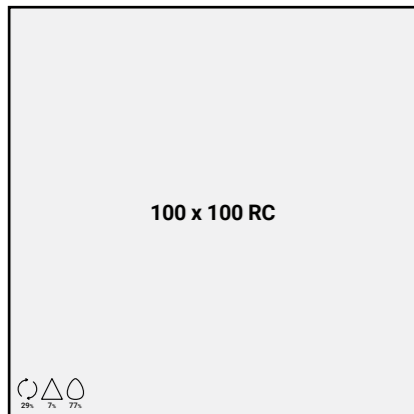

SALISBURY WHITE CTE2/R10 / B310  
SALISBURY WHITE LAP / B430  
SALISBURY GREY CTE2/R10 / B310  
SALISBURY GREY LAP / B430  
SALISBURY DARK CTE2/R10 / B310  
SALISBURY DARK LAP / B430  
SALISBURY SAND CTE2/R10 / B310  
SALISBURY SAND LAP / B430

SALISBURY 20 WHITE CTE3/R11/C / B600  
SALISBURY 20 GREY CTE3/R11/C / B600  
SALISBURY 20 DARK CTE3/R11/C / B600  
SALISBURY 20 SAND CTE3/R11/C / B600



SALISBURY WHITE CTE2/R10 / B310  
SALISBURY WHITE LAP / B430  
SALISBURY GREY CTE2/R10 / B310  
SALISBURY GREY LAP / B430  
SALISBURY DARK CTE2/R10 / B310  
SALISBURY DARK LAP / B430  
SALISBURY SAND CTE2/R10 / B310  
SALISBURY SAND LAP / B430

SALISBURY 20 WHITE CTE3/R11/C / B600  
SALISBURY 20 GREY CTE3/R11/C / B600  
SALISBURY 20 DARK CTE3/R11/C / B600  
SALISBURY 20 SAND CTE3/R11/C / B600



SALISBURY 20 WHITE CTE3/R11/C / B410  
SALISBURY 20 GREY CTE3/R11/C / B410  
SALISBURY 20 DARK CTE3/R11/C / B410  
SALISBURY 20 SAND CTE3/R11/C / B410

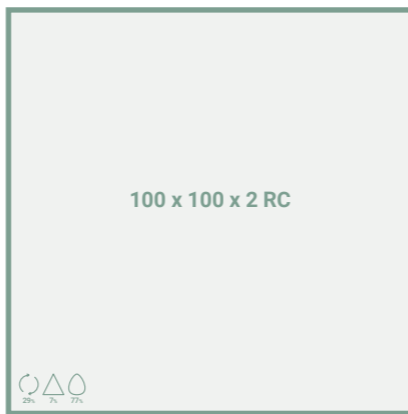

100 x 100 x 2 RC



60 x 120 x 2 RC

SALISBURY GREY 60x120 RC  
SALISBURY GREY 23,6"x47,2" RC



EJEMPLO DE VARIEDAD GRÁFICA  
GRAPHIC VARIETY EXAMPLE

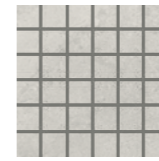

MS SALISBURY WHITE  
30x30 / C75

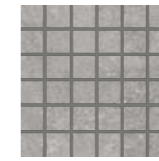

MS SALISBURY GREY  
30x30 / C75



MS SALISBURY DARK  
30x30 / C75

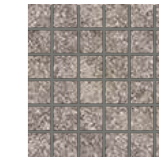

MS SALISBURY SAND  
30x30 / C75



SALISBURY-REL WHITE  
31,6x60,8 / B205



SALISBURY-REL GREY  
31,6x60,8 / B205



SALISBURY-REL SAND  
31,6x60,8 / B205



SALISBURY-REL DARK  
31,6x60,8 / B205



SALISBURY-REL 7 WHITE  
40x120 RC / B310



SALISBURY-REL 7 GREY  
40x120 RC / B310



SALISBURY-REL 7 SAND  
40x120 RC / B310



SALISBURY-REL 7 DARK  
40x120 RC / B310



SALISBURY-REL 7 WARM  
40x120 RC / B310



SALISBURY-REL 7 COLD  
40x120 RC / B310

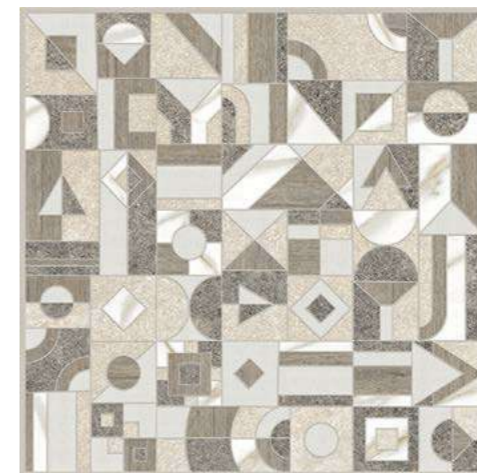

SALISBURY-DEC WARM CTE2/R10 / 60x60 RC / B226  
SALISBURY-DEC WARM CTE2/R10 / 100x100 RC / B310  
SALISBURY-DEC WARM LAP / 100x100 RC / B430  
SALISBURY-DEC 20 WARM / 60x60 RC / B410  
SALISBURY-DEC 20 WARM / 100x100 RC / B600

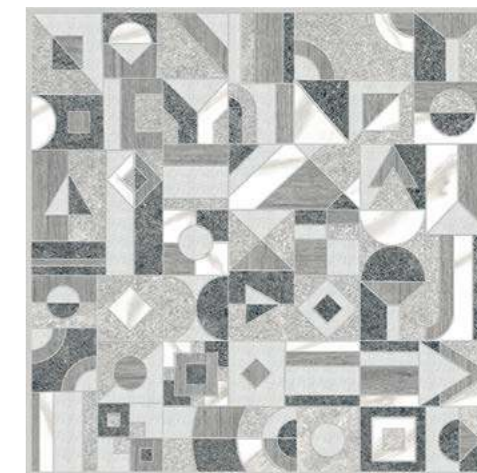

SALISBURY-DEC COLD CTE2/R10 / 60x60 RC / B226  
SALISBURY-DEC COLD CTE2/R10 / 100x100 RC / B310  
SALISBURY-DEC COLD LAP / 100x100 RC / B430  
SALISBURY-DEC 20 COLD / 60x60 RC / B410  
SALISBURY-DEC 20 COLD / 100x100 RC / B600



white



grey



oxide

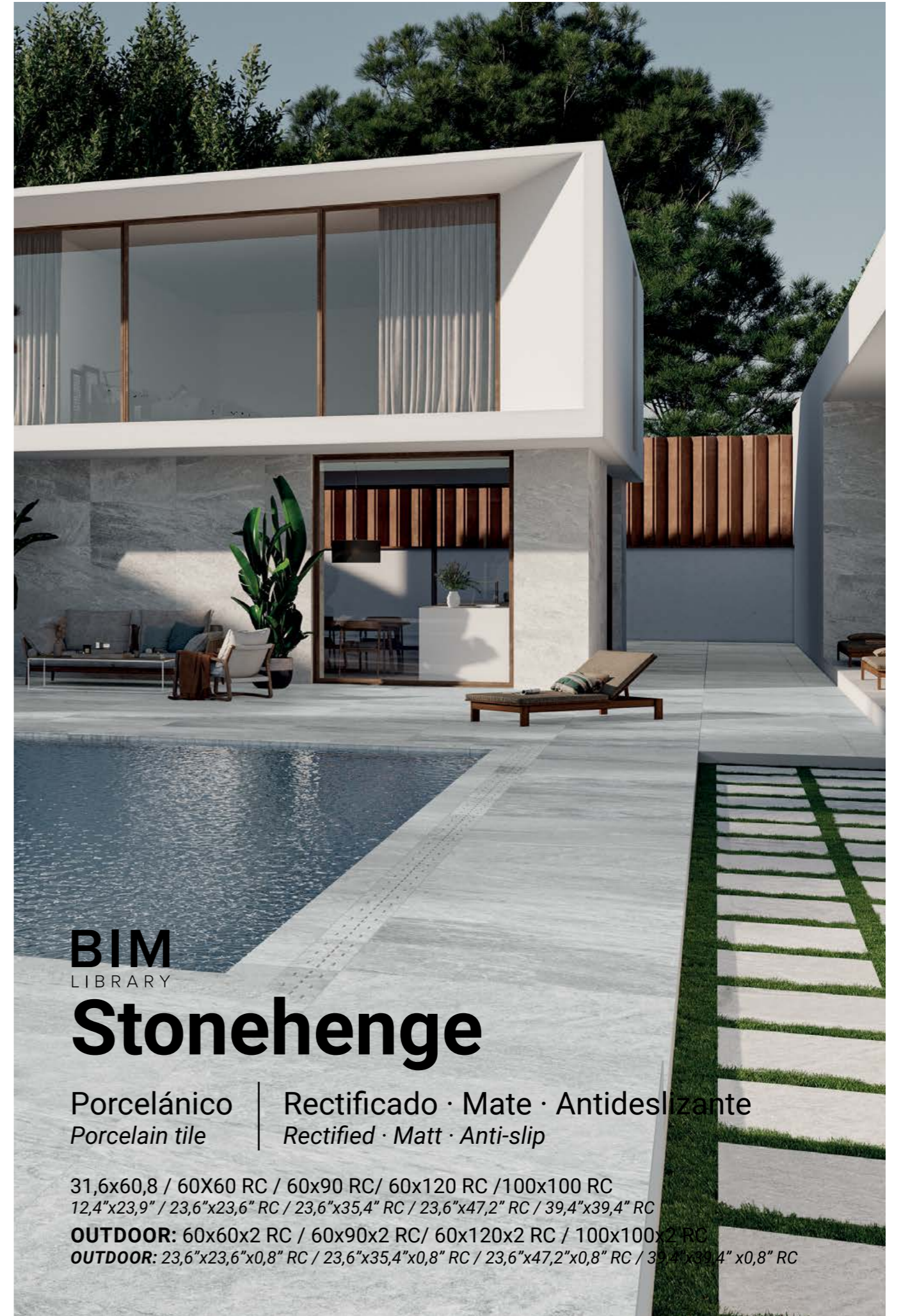

BIM  
LIBRARY

# Stonehenge

Porcelánico  
*Porcelain tile*

Rectificado · Mate · Antideslizante  
*Rectified · Matt · Anti-slip*

31,6x60,8 / 60X60 RC / 60x90 RC / 60x120 RC / 100x100 RC  
12,4"x23,9" / 23,6"x23,6" RC / 23,6"x35,4" RC / 23,6"x47,2" RC / 39,4"x39,4" RC

**OUTDOOR:** 60x60x2 RC / 60x90x2 RC / 60x120x2 RC / 100x100x2 RC

**OUTDOOR:** 23,6"x23,6"x0,8" RC / 23,6"x35,4"x0,8" RC / 23,6"x47,2"x0,8" RC / 39,4"x39,4" x0,8" RC

OUTDOOR

**31,6 x 60,8**

STONEHENGE WHITE CTE2/R10 / B186  
STONEHENGE WHITE CTE3/R11/C / B186  
STONEHENGE GREY CTE2/R10 / B186  
STONEHENGE GREY CTE3/R11/C / B186  
STONEHENGE OXIDE CTE2/R10 / B186  
STONEHENGE OXIDE CTE3/R11/C / B186

**60 x 60 RC**

STONEHENGE WHITE CTE2/R10 / B226  
STONEHENGE GREY CTE2/R10 / B226  
STONEHENGE OXIDE CTE2/R10 / B226

**60 x 90 RC**

STONEHENGE WHITE CTE2/R10 / B273  
STONEHENGE GREY CTE2/R10 / B273  
STONEHENGE OXIDE CTE2/R10 / B273

**100 x 100 RC**

STONEHENGE WHITE CTE2/R10 / B310  
STONEHENGE GREY CTE2/R10 / B310  
STONEHENGE OXIDE CTE2/R10 / B310

**60 x 120 RC**

STONEHENGE WHITE CTE2/R10 / B310  
STONEHENGE GREY CTE2/R10 / B310  
STONEHENGE OXIDE CTE2/R10 / B310

STONEHENGE 20 WHITE CTE3/R11/C / B410  
STONEHENGE 20 GREY CTE3/R11/C / B410  
STONEHENGE 20 OXIDE CTE3/R11/C / B410

**60 x 60 x 2 RC**

STONEHENGE 20 WHITE CTE3/R11/C / B524  
STONEHENGE 20 GREY CTE3/R11/C / B524  
STONEHENGE 20 OXIDE CTE3/R11/C / B524

**60 x 90 x 2 RC**

STONEHENGE 20 WHITE CTE3/R11/C / B600  
STONEHENGE 20 GREY CTE3/R11/C / B600  
STONEHENGE 20 OXIDE CTE3/R11/C / B600

**100 x 100 x 2 RC**

STONEHENGE 20 WHITE CTE3/R11/C / B600  
STONEHENGE 20 GREY CTE3/R11/C / B600  
STONEHENGE 20 OXIDE CTE3/R11/C / B600

**60 x 120 x 2 RC**

EJEMPLO DE VARIEDAD GRÁFICA  
GRAPHIC VARIETY EXAMPLE



STONEHENGE WHITE 60x120 RC  
STONEHENGE WHITE 23,6"x47,2" RC



MS STONEHENGE WHITE  
30x30 / C75

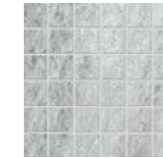

MS STONEHENGE GREY  
30x30 / C75



MS STONEHENGE OXIDE  
30x30 / C75



STONEHENGE REL WHITE CTE1/R9/A  
31,6x60,8 / B205



STONEHENGE REL GREY CTE1/R9/A  
31,6x60,8 / B205



STONEHENGE REL OXIDE CTE1/R9/A  
31,6x60,8 / B205



STONEHENGE ELIO WHITE CTE1/R9/A  
31,6x60,8 / B205



STONEHENGE ELIO GREY CTE1/R9/A  
31,6x60,8 / B205



STONEHENGE ELIO OXIDE CTE1/R9/A  
31,6x60,8 / B205



STONEHENGE WHITE 31,6x60,8 RC / STONEHENGE REL WHITE 31,6x60,8 RC





white

grey

ivory

smoke

taupe



# Sunset

Porcelánico  
Porcelain tile

Mate  
Matt

31,6x60,8 / 47,2x47,2  
12,4"x23,9" / 18,6"x18,6"

REVESTIMIENTO: 20x60  
WALL TILE: 7,9"x23,6"



SUNSET WHITE / B115  
SUNSET GREY / B115  
SUNSET IVORY / B115  
SUNSET SMOKE / B115  
SUNSET TAUPE / B115

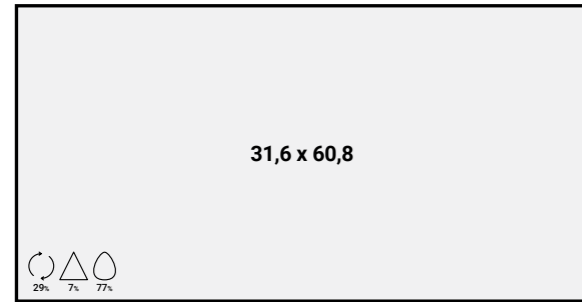

SUNSET WHITE / B186  
SUNSET GREY / B186  
SUNSET IVORY / B186  
SUNSET SMOKE / B186  
SUNSET TAUPE / B186

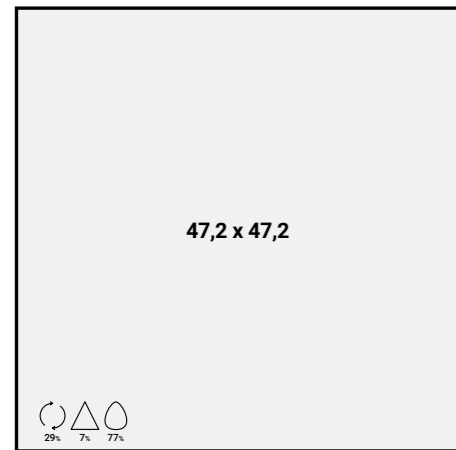

SUNSET WHITE / B186  
SUNSET GREY / B186  
SUNSET IVORY / B186  
SUNSET SMOKE / B186  
SUNSET TAUPE / B186

PAVIMENTO COORDINADO  
COORDINATED FLOOR TILE



SUNSET WHITE 47,2x47,2 / B186  
SUNSET GREY 47,2x47,2 / B186  
SUNSET SMOKE 47,2x47,2 / B186  
SUNSET IVORY 47,2x47,2 / B186  
SUNSET TAUPE 47,2x47,2 / B186

EJEMPLO DE VARIEDAD GRÁFICA  
GRAPHIC VARIETY EXAMPLE



SUNSET GREY 31,6x60,8  
SUNSET GREY 12,4"x23,9"



SUNSET CRAFT WHITE  
31,6x60,8 / B205



SUNSET CRAFT GREY  
31,6x60,8 / B205



SUNSET CRAFT IVORY  
31,6x60,8 / B205



SUNSET CRAFT SMOKE  
31,6x60,8 / B205



SUNSET CRAFT TAUPE  
31,6x60,8 / B205



SUNSET-10-HIT SHUTTER WHITE  
20x60 / B138



SUNSET-10-HIT SHUTTER GREY  
20x60 / B138



SUNSET-10-HIT SHUTTER IVORY  
20x60 / B138



SUNSET-10-HIT SHUTTER SMOKE  
20x60 / B138



SUNSET-10-HIT SHUTTER TAUPE  
20x60 / B138



SUNSET WHITE 20x60 / SUNSET 10 HIT SHUTTER WHITE 20x60 / SUNSET WHITE 47,2x47,2



white

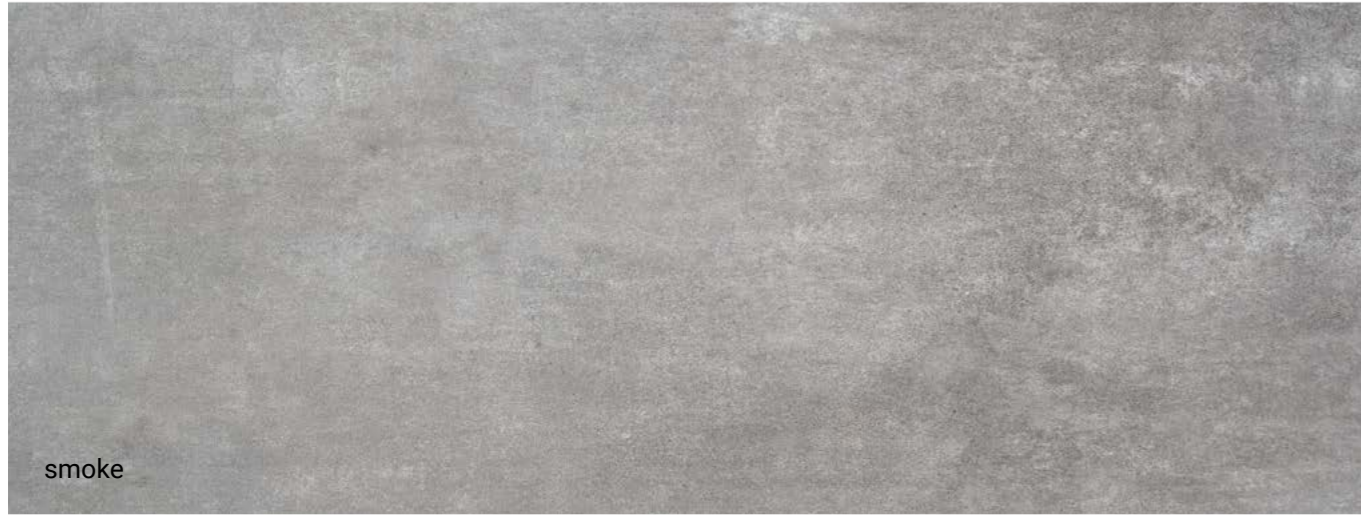

smoke

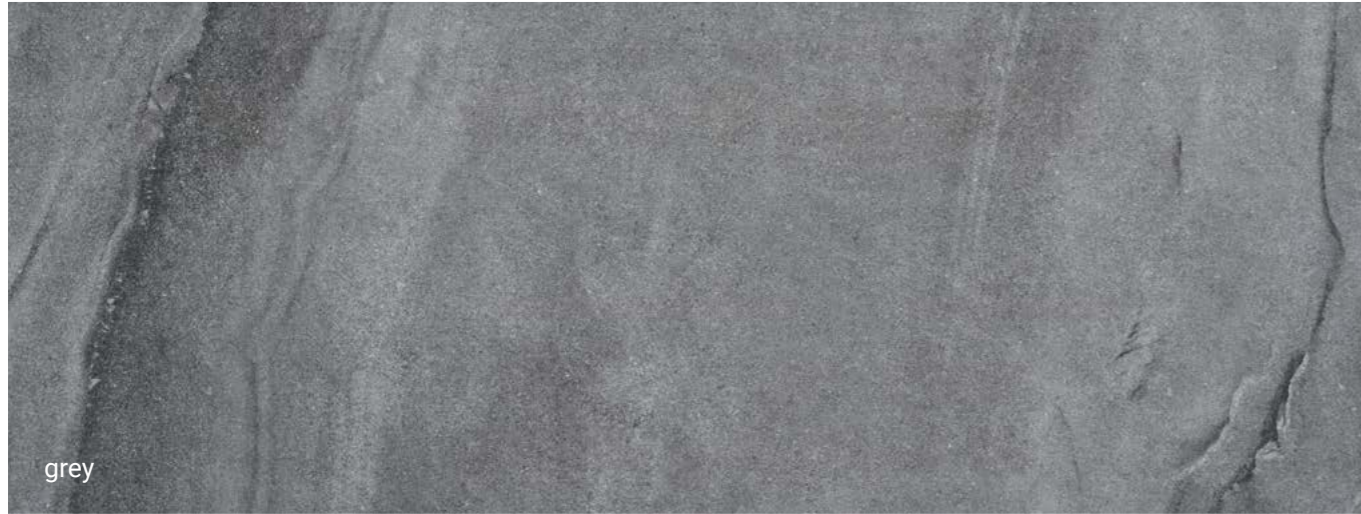

grey



beige



# BIM LIBRARY Valley

Porcelánico | Rectificado · Mate · Antideslizante  
Porcelain tile | Rectified · Matt · Anti-slip

31,6x60,8 / 60x60 RC / 60x90 RC / 60x120 RC / 100x100 RC  
12,4"x23,9" / 23,6"x23,6" RC / 23,6"x35,4" / 23,6"x47,2" RC / 39,4x39,4RC

**OUTDOOR:** 60x60x2 RC / 60x90x2 RC / 60x120x2 RC / 100x100x2 RC

**OUTDOOR:** 23,6"x23,6"x0,8" RC / 23,6"x35,4"x0,8" RC / 23,6"x47,2"x0,8" RC / 39,4"x39,4"x0,8" RC

**31,6 x 60,8**

VALLEY WHITE CTE2/R10 / B186  
VALLEY WHITE CTE3/R11/C / B186  
VALLEY SMOKE CTE2/R10 / B186  
VALLEY SMOKE CTE3/R11/C / B186  
VALLEY GREY CTE2/R10 / B186  
VALLEY GREY CTE3/R11/C / B186  
VALLEY BEIGE CTE2/R10 / B186  
VALLEY BEIGE CTE3/R11/C / B186

**60 x 60 RC**

VALLEY WHITE CTE2/R10 / B226  
VALLEY SMOKE CTE2/R10 / B226  
VALLEY GREY CTE2/R10 / B226  
VALLEY BEIGE CTE2/R10 / B226

**60 x 60 x 2 RC**

VALLEY 20 WHITE CTE3/R11/C / B410  
VALLEY 20 SMOKE CTE3/R11/C / B410  
VALLEY 20 GREY CTE3/R11/C / B410  
VALLEY 20 BEIGE CTE3/R11/C / B410

**60 x 90 RC**

VALLEY WHITE CTE2/R10 / B273  
VALLEY SMOKE CTE2/R10 / B273  
VALLEY GREY CTE2/R10 / B273  
VALLEY BEIGE CTE2/R10 / B273

**60 x 90 x 2 RC**

VALLEY 20 WHITE CTE3/R11/C / B524  
VALLEY 20 SMOKE CTE3/R11/C / B524  
VALLEY 20 GREY CTE3/R11/C / B524  
VALLEY 20 BEIGE CTE3/R11/C / B524

**60 x 120 RC**

VALLEY WHITE CTE2/R10 / B310  
VALLEY SMOKE CTE2/R10 / B310  
VALLEY GREY CTE2/R10 / B310  
VALLEY BEIGE CTE2/R10 / B310

**60 x 120 x 2 RC**

VALLEY 20 WHITE CTE3/R11/C / B600  
VALLEY 20 SMOKE CTE3/R11/C / B600  
VALLEY 20 GREY CTE3/R11/C / B600  
VALLEY 20 BEIGE CTE3/R11/C / B600

**100 x 100 RC**

VALLEY WHITE CTE2/R10 / B310  
VALLEY SMOKE CTE2/R10 / B310  
VALLEY GREY CTE2/R10 / B310  
VALLEY BEIGE CTE2/R10 / B310

**100 x 100 x 2 RC**

VALLEY 20 WHITE CTE3/R11/C / B600  
VALLEY 20 SMOKE CTE3/R11/C / B600  
VALLEY 20 GREY CTE3/R11/C / B600  
VALLEY 20 BEIGE CTE3/R11/C / B600

EJEMPLO DE VARIEDAD GRÁFICA  
GRAPHIC VARIETY EXAMPLE

VALLEY SMOKE 31,6x60,8  
VALLEY SMOKE 12,4"x23,9"

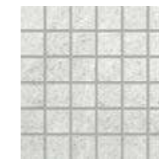

MS VALLEY WHITE  
30x30 / C75

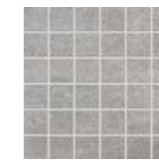

MS VALLEY SMOKE  
30x30 / C75

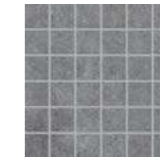

MS VALLEY GREY  
30x30 / C75



MS VALLEY BEIGE  
30x30 / C75



VALLEY REL WHITE  
31,6x60,8 / B205



VALLEY REL SMOKE  
31,6x60,8 / B205



VALLEY REL GREY  
31,6x60,8 / B205



VALLEY REL BEIGE  
31,6x60,8 / B205



VALLEY SMOKE 100x100 RC / VALLEY SMOKE 31,6x60,8 / VALLEY REL SMOKE 31,6x60,8



**MÁRMOL**  
*MARBLE*



bianco

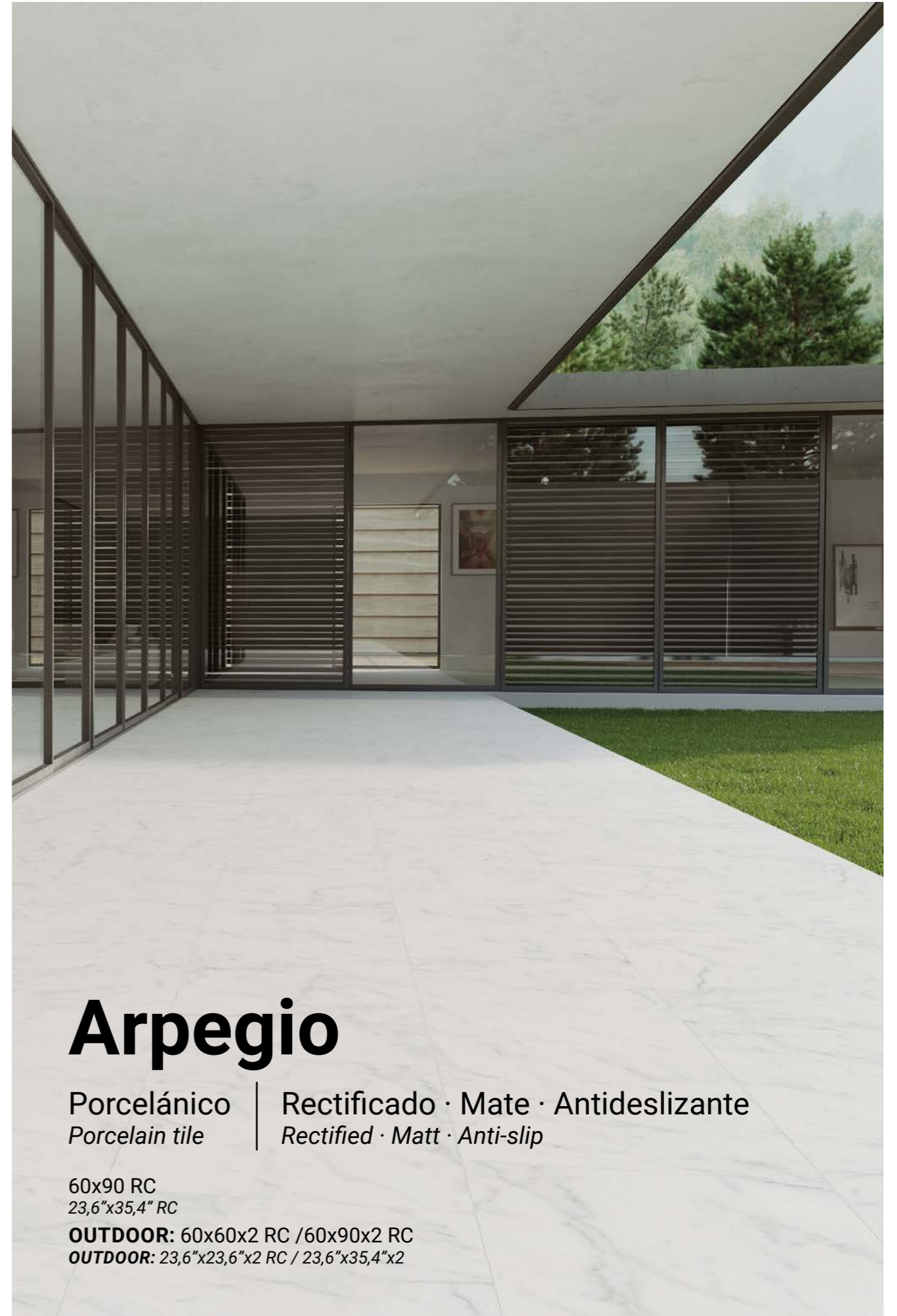

# Arpegio

Porcelánico  
*Porcelain tile*

Rectificado · Mate · Antideslizante  
*Rectified · Matt · Anti-slip*

60x90 RC  
23,6"x35,4" RC

**OUTDOOR:** 60x60x2 RC / 60x90x2 RC  
**OUTDOOR:** 23,6"x23,6"x2 RC / 23,6"x35,4"x2

OUTDOOR 20<sup>EE</sup>



ARPEGIO 20 BIANCO CTE3/R11 / B410

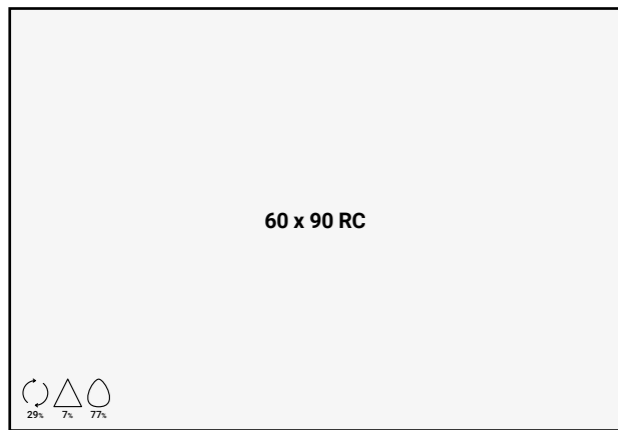

ARPEGIO BIANCO / B273



ARPEGIO 20 BIANCO CTE3/R11 / B524

EJEMPLO DE VARIEDAD GRÁFICA  
GRAPHIC VARIETY EXAMPLE

ARPEGIO 20 BIANCO 60x60 RC  
ARPEGIO 20 BIANCO 23,6" x 23,6" RC

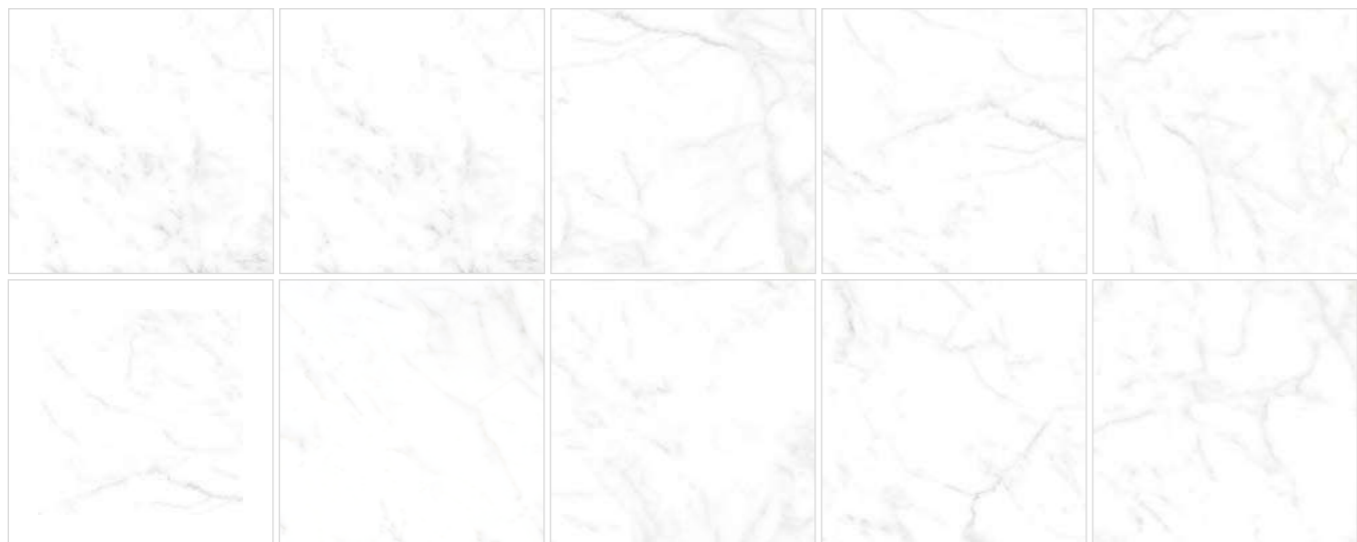

ARPEGIO 20 BIANCO 60x60 RC



gold



# Calacatta Gold

Porcelánico | Reetificado · Pulido  
Porcelain tile | Rectified · Polished

60x120 RCP / 75x150 RCP / 120x120 RCP  
23,6"x47,2" RCP / 29,5"x59" RCP / 47,2"x47,2" RCP

**PASTA BLANCA:** 33x100 RC

**WHITE BODY:** 12,9"x39,4" RC



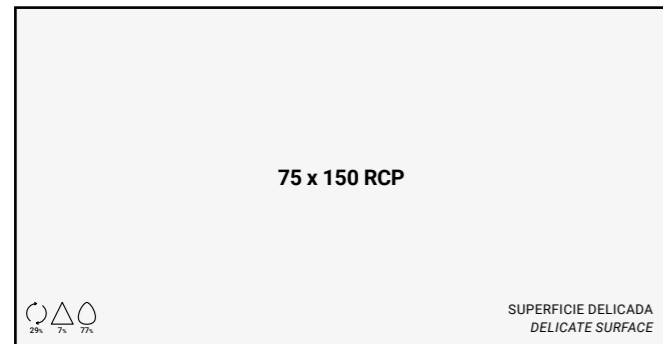
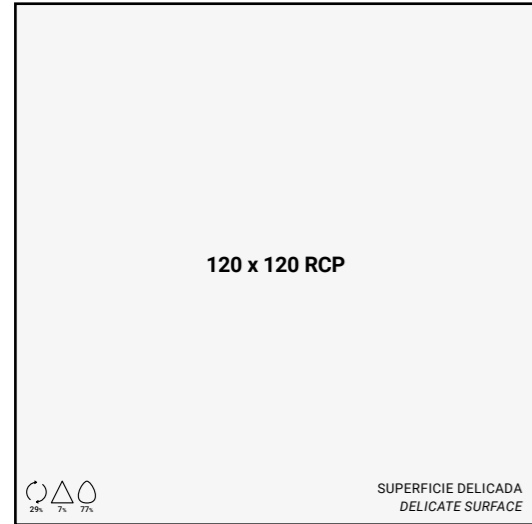
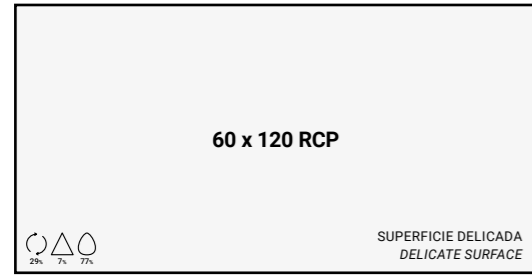

EJEMPLO DE VARIEDAD GRÁFICA  
GRAPHIC VARIETY EXAMPLE

CALACATTA GOLD 120x120 RCP  
CALACATTA GOLD 47,2"x 47,2" RCP



COMPLEMENTOS  
ACCESORIES

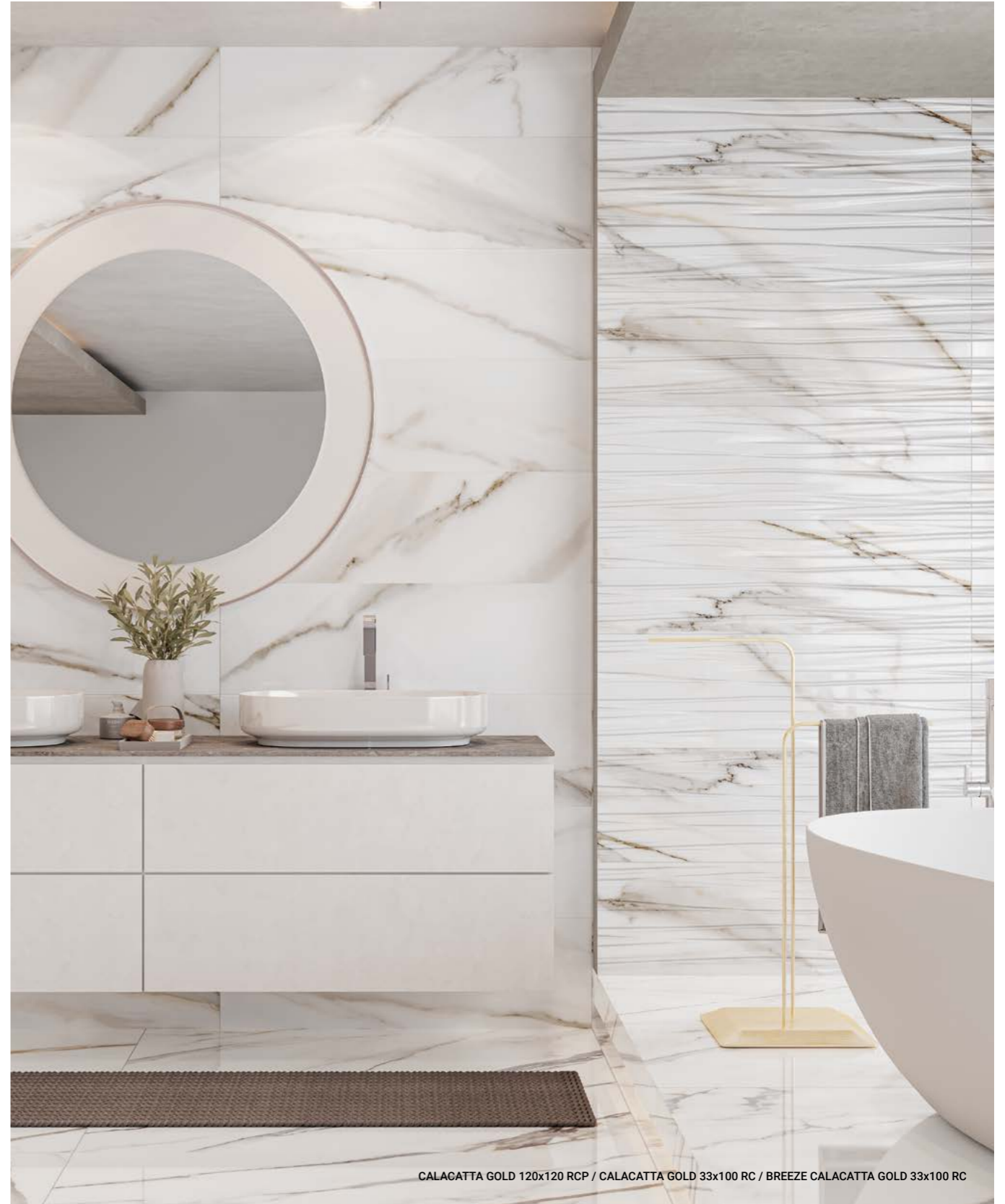



bianco



# Capraia

Porcelánico  
*Porcelain tile*

Rectificado · Pulido  
*Rectified · Polished*

60x120 RCP / 75x150 RCP / 120x120 RCP  
23,6"x47,2" RCP / 29,5"x59" RCP / 47,2"x47,2" RCP

**PASTA BLANCA:** 33x100 RC  
**WHITE BODY:** 12,9"x39,4" RC

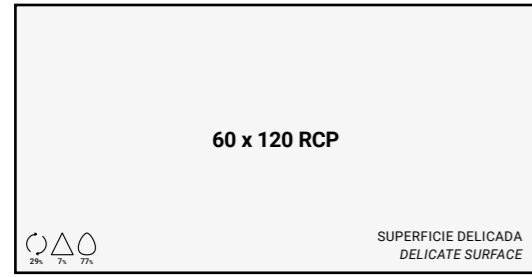

CAPRAIA BIANCO / B360



CAPRAIA BIANCO/ B208

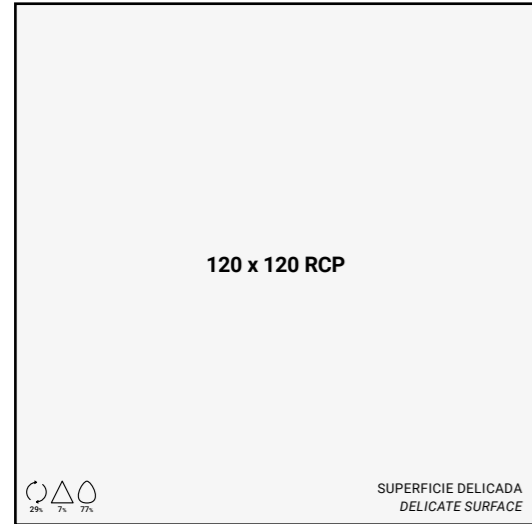

CAPRAIA BIANCO / B430

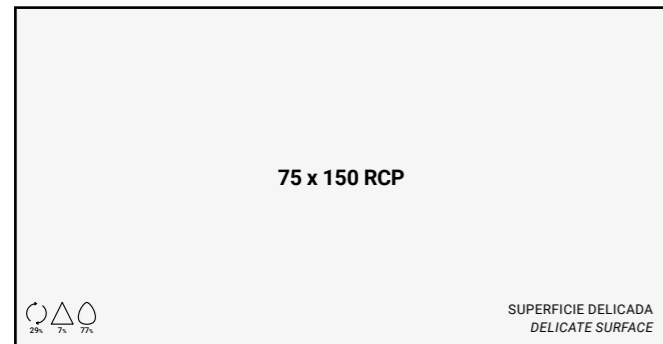

CAPRAIA BIANCO / B430

EJEMPLO DE VARIEDAD GRÁFICA  
GRAPHIC VARIETY EXAMPLE

CAPRAIA BIANCO 120x120 RCP  
CAPRAIA BIANCO 47,2"x47,2" RCP



COMPLEMENTOS  
ACCESSORIES



BREEZE CAPRAIA BIANCO  
33x100 RC / C230



VELVET CAPRAIA BIANCO  
33x100 RC / C230



CAPRAIA BIANCO 30x100 RC / BREEZE CAPRAIA BIANCO 30x100 RC / GLAMORA ROVERE 29,5x120 RC



bianco



grigio



crema



# Eleganza

Porcelánico  
*Porcelain tile*

Rectificado · Pulido · Brillo  
*Rectified · Polished · Gloss*

60x120 RCP / 75x150 RCP / 120x120 RCP  
23,6"x47,2" RCP / 29,5"x59" RCP / 47,2"x47,2" RCP

**PASTA BLANCA:** 33x100 RC

**WHITE BODY:** 12,9"x39,4" RC

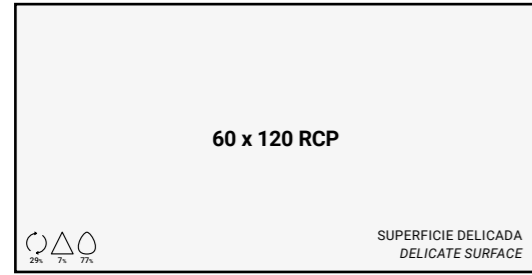

ELEGANZA BIANCO / B360  
ELEGANZA GRIGIO / B360  
ELEGANZA CREMA / B360

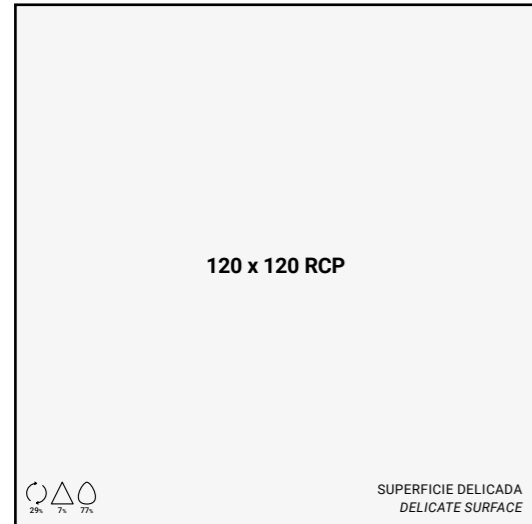

ELEGANZA BIANCO / B430  
ELEGANZA GRIGIO / B430  
ELEGANZA CREMA / B430

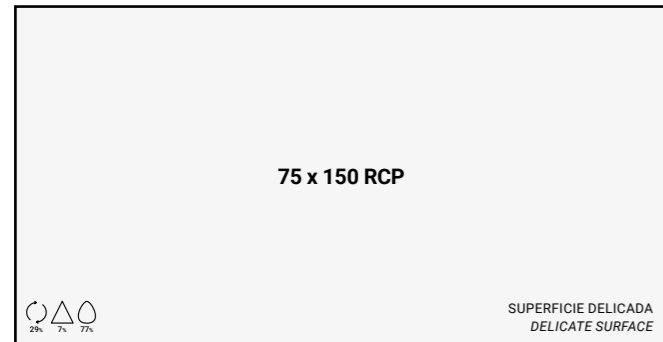

ELEGANZA BIANCO / B430  
ELEGANZA GRIGIO / B430  
ELEGANZA CREMA / B430

EJEMPLO DE VARIEDAD GRÁFICA  
GRAPHIC VARIETY EXAMPLE

ELEGANZA GRIGIO 60x120 RCP / ELEGANZA BIANCO 60x120 RCP  
ELEGANZA GRIGIO 23,6"x47,2" RCP / ELEGANZA BIANCO 23,6"x47,2" RCP



COMPLEMENTOS  
ACCESSORIES



ELEGANZA REL BIANCO  
33x100 RC / B230



ELEGANZA REL GRIGIO  
33x100 RC / B230



ELEGANZA REL CREMA  
33x100 RC / B230



ELEGANZA GRIGIO 33x100 RC / ELEGANZA REL GRIGIO 33x100 RC / ELEGANZA DEC GRIGIO 33x100 RC



ELEGANZA DEC BIANCO  
33x100 RC / B230



ELEGANZA DEC GRIGIO  
33x100 RC / B230



ELEGANZA DEC CREMA  
33x100 RC / B230

EJEMPLO DE VARIEDAD GRÁFICA  
GRAPHIC VARIETY EXAMPLE

ELEGANZA CREMA 60x120 RCP  
ELEGANZA CREMA 23,6"x47,2" RCP

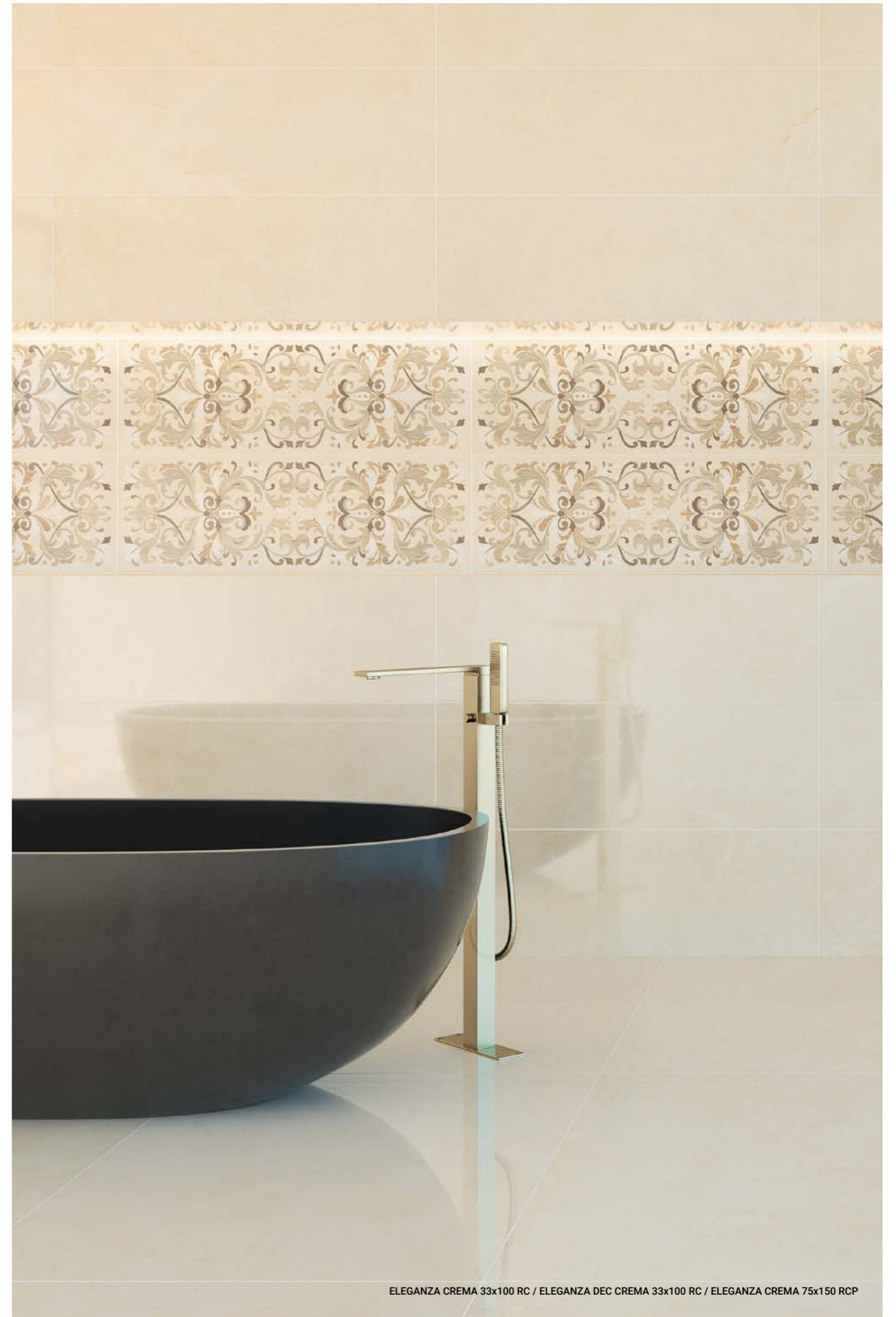

ELEGANZA CREMA 33x100 RC / ELEGANZA DEC CREMA 33x100 RC / ELEGANZA CREMA 75x150 RCP



white



# Kea

Porcelánico  
*Porcelain tile*

Rectificado · Mate  
*Rectified · Matt*

30,6x59,8 RC  
12,4"x23,9" RC

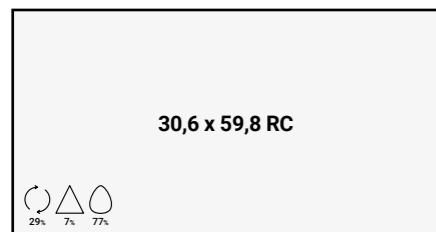

KEA WHITE CTE1 / B200

EJEMPLO DE VARIEDAD GRÁFICA  
GRAPHIC VARIETY EXAMPLE

KEA WHITE 30,6x59,8 RC  
KEA WHITE 12,4"x23,9" RC



DE LANDSCAPE A  
30,6x59,8 RC / C105



DE LANDSCAPE B  
30,6x59,8 RC / C105



KEA-REL WHITE (1-6)  
30,6x59,8 RC / B219

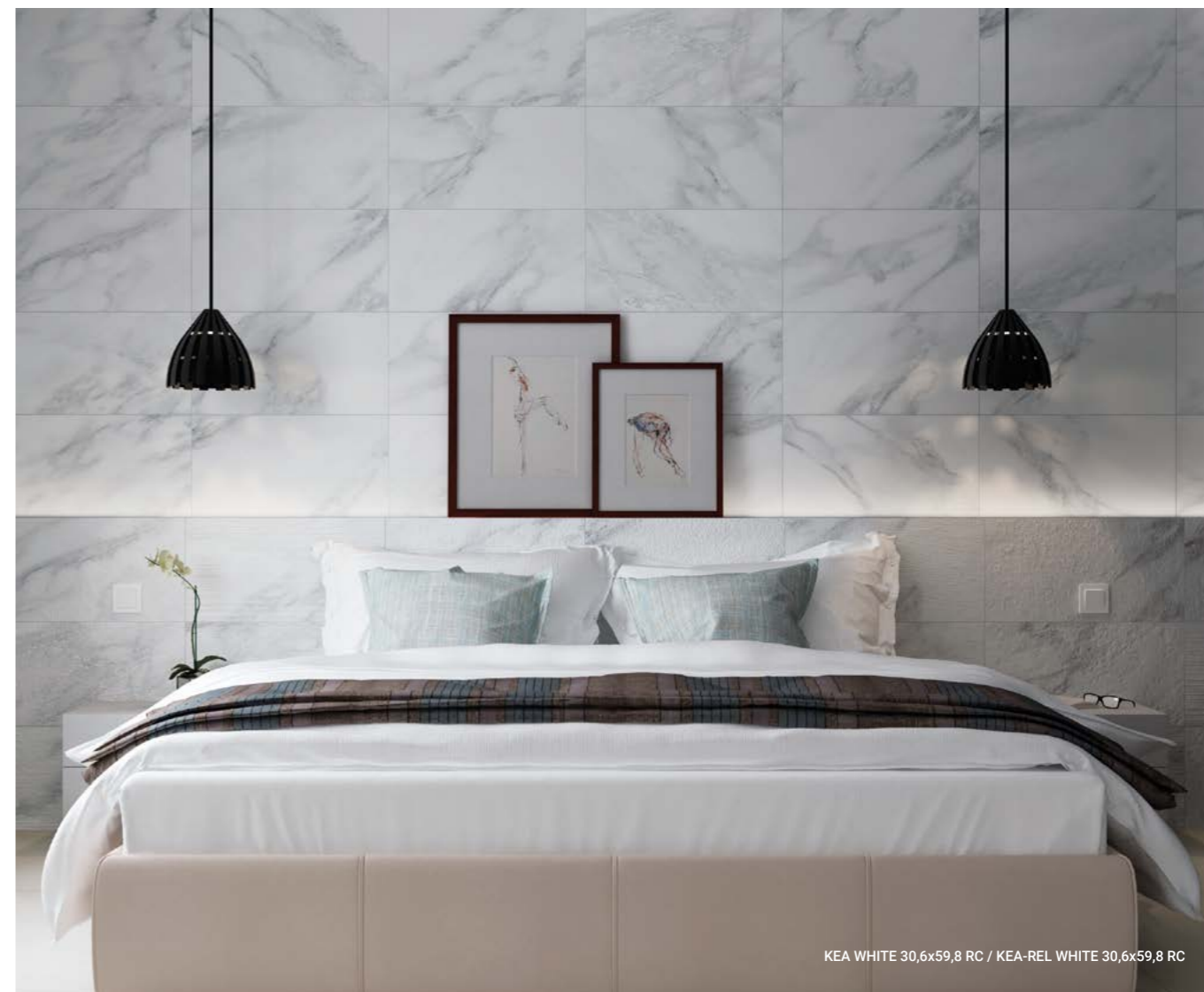

KEA WHITE 30,6x59,8 RC / KEA-REL WHITE 30,6x59,8 RC





white



# Mitra

Porcelánico  
*Porcelain tile*

Rectificado · Mate  
*Rectified · Matt*

60x60 RC  
23,6"x23,6"

**VIKER:** 40x120 RC  
**VIKER:** 15,7"x47,2" RC

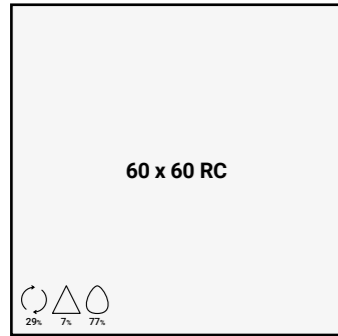

MITRA WHITE / B226



MITRA 7 WHITE / B288



MITRA 7 REL WHITE  
40x120 RC / B310

EJEMPLO DE VARIEDAD GRÁFICA  
GRAPHIC VARIETY EXAMPLE

MITRA 7 WHITE 40X120 RC  
MITRA 7 WHITE 15,7"x47,2" RC

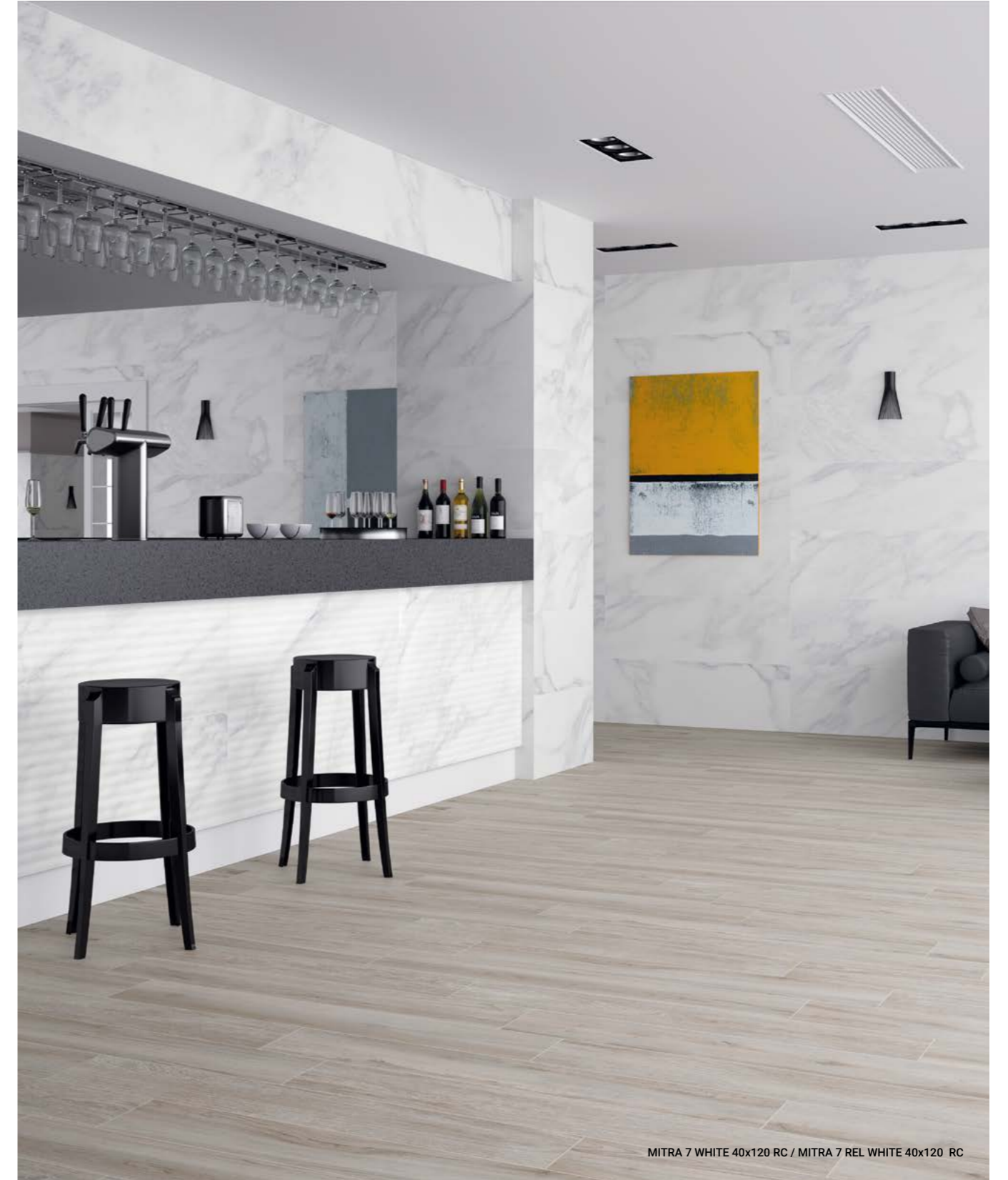

MITRA 7 WHITE 40x120 RC / MITRA 7 REL WHITE 40x120 RC



ice

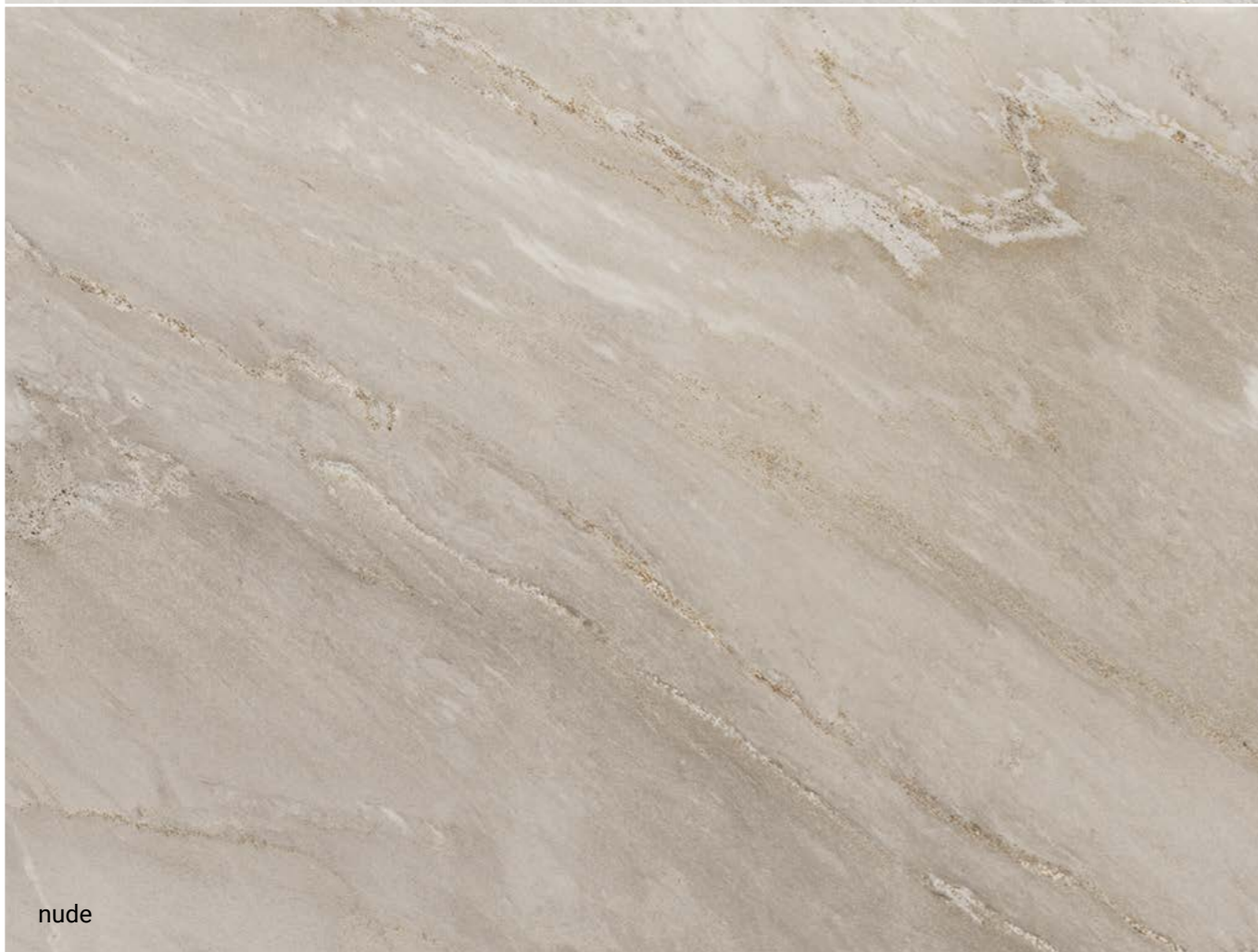

nude



# Ombra

Porcelánico  
*Porcelain tile*

Rectificado · Pulido  
*Rectified · Polished*

60x120 RCP / 75x150 RCP / 120x120 RCP  
23,6" x 47,2" RCP / 29,5" x 59" RCP / 47,2" x 47,2" RCP

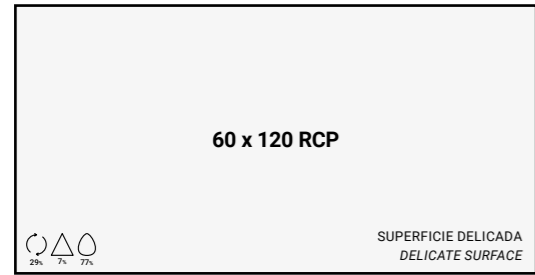

OMBRA ICE / B360  
OMBRA NUDE / B360

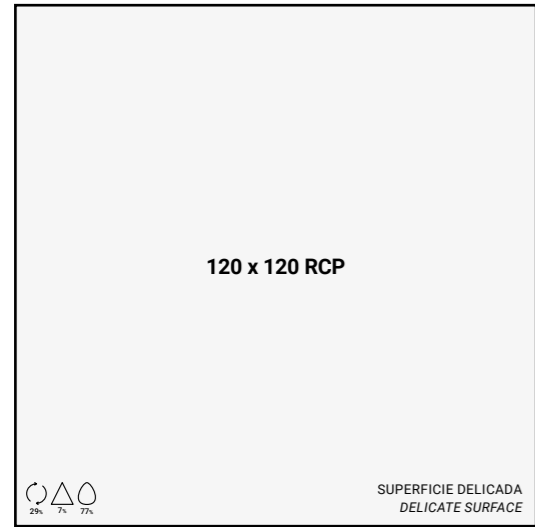

OMBRA ICE / B430  
OMBRA NUDE / B430

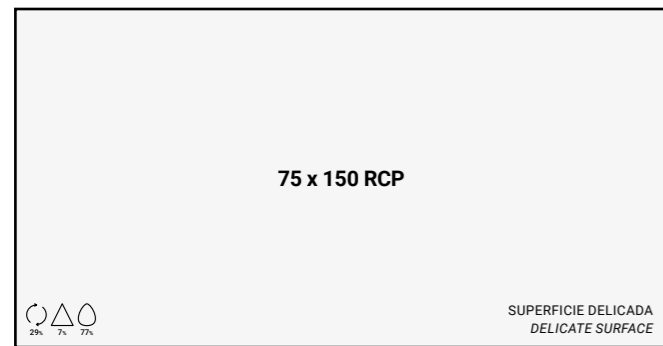

OMBRA ICE / B430  
OMBRA NUDE / B430

EJEMPLO DE VARIEDAD GRÁFICA  
GRAPHIC VARIETY EXAMPLE

OMBRA NUDE 60x120 RCP  
OMBRA NUDE 23,6"x47,2" RCP



OMBRA NUDE 120x120 RCP



marfil



# Raffaello

Porcelánico  
*Porcelain tile*

Rectificado · Pulido  
*Rectified · Polished*

60x120 RCP / 75x150 RCP / 120x120 RCP  
23,6"x47,2" RCP / 29,5"x59" RCP / 47,2"x47,2" RCP

**PASTA BLANCA:** 33x100 RC  
**WHITE BODY:** 12,9"x39,4" RC

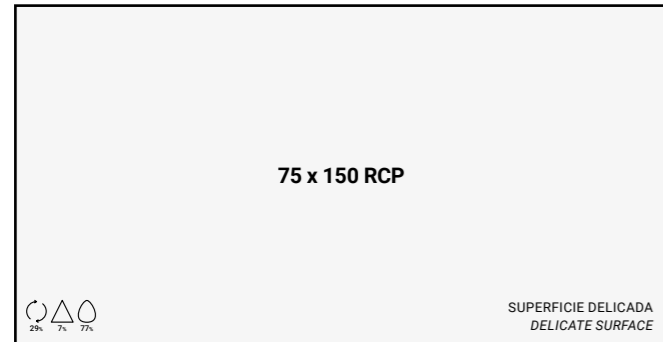
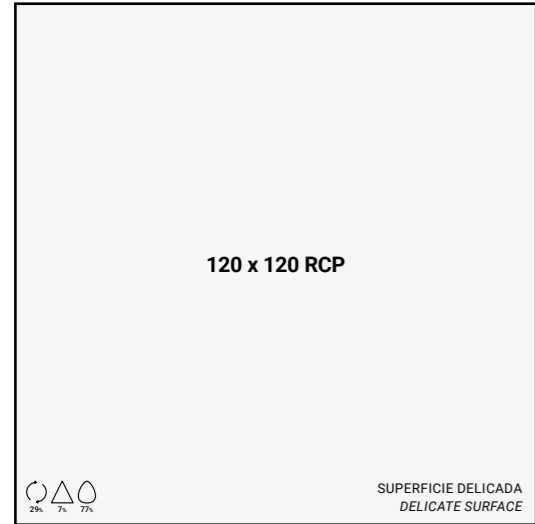
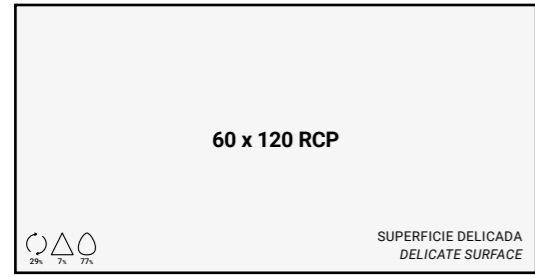

EJEMPLO DE VARIEDAD GRÁFICA  
GRAPHIC VARIETY EXAMPLE

RAFFAELLO MARFIL 120x120 RCP  
RAFFAELLO MARFIL 47,2"x47,2" RCP



COMPLEMENTOS  
ACCESSORIES



BREEZE RAFFAELLO MARFIL 33x100 RC / RAFFAELLO MARFIL 33x100 RC / GLAMORA ROVERE 29,5x120 RC

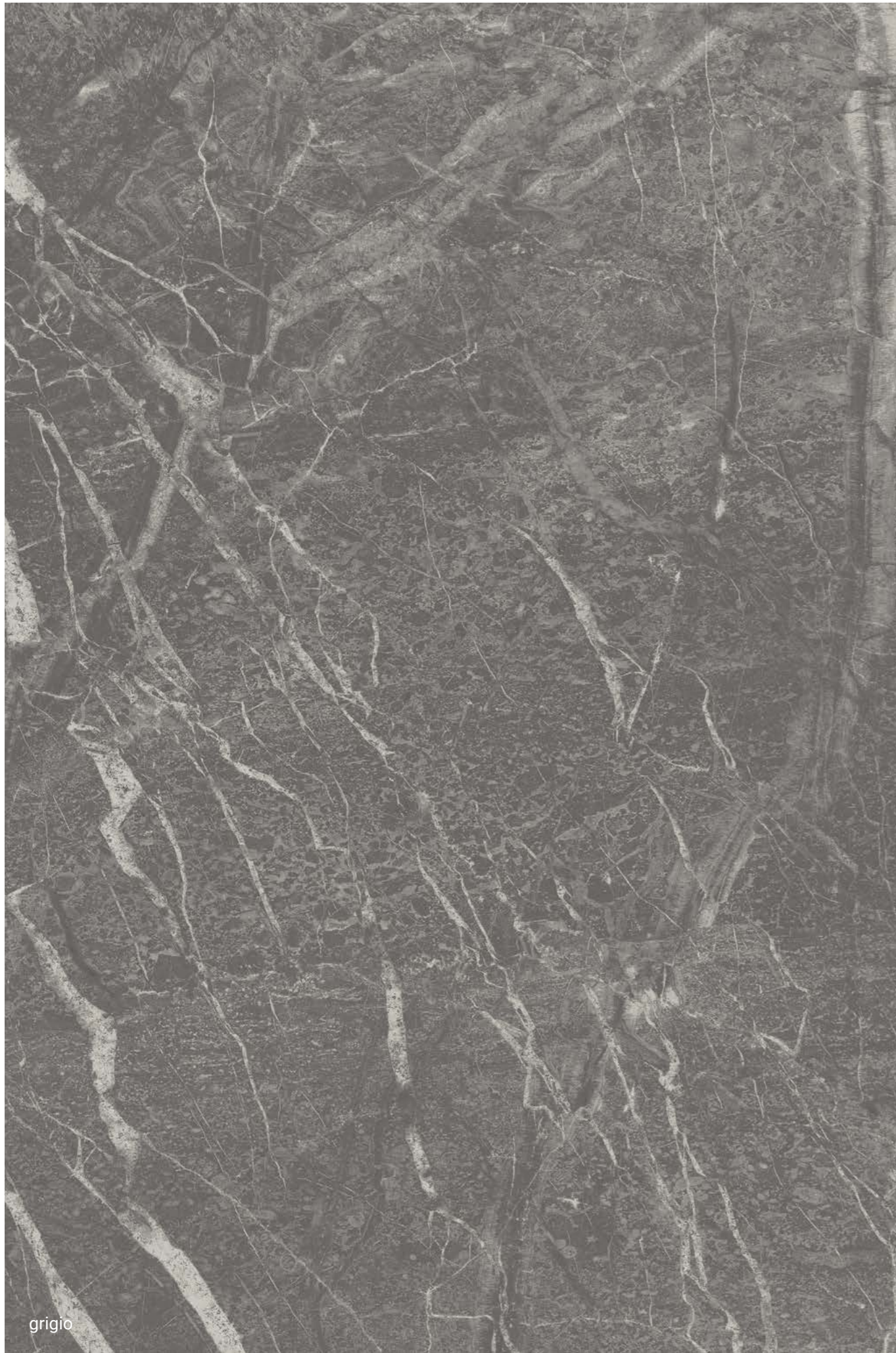

grigio



# Shadow

Porcelánico  
Porcelain tile

Rectificado · Pulido  
Rectified · Polished

60x120 RCP / 75x150 RCP / 120x120 RCP  
23,6"x47,2" RCP / 29,5"x59" RCP / 47,2"x47,2" RCP

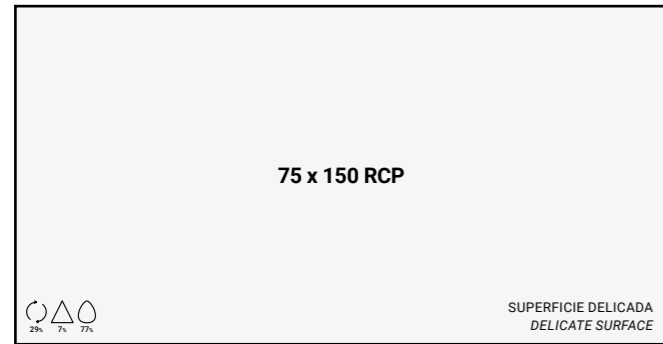
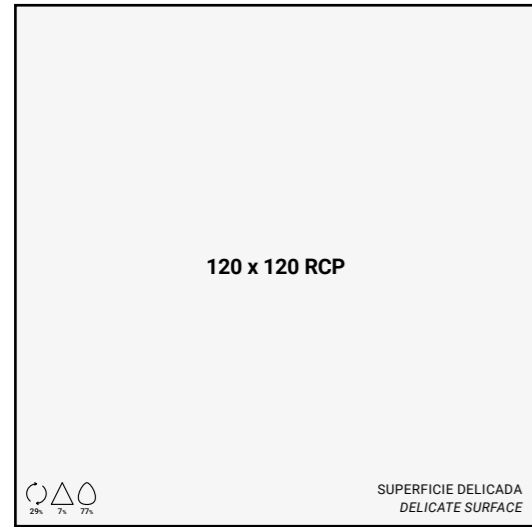
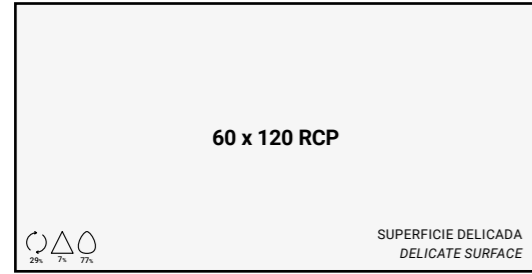

EJEMPLO DE VARIEDAD GRÁFICA  
GRAPHIC VARIETY EXAMPLE

SHADOW GRIGIO 120x120 RCP  
SHADOW GRIGIO 47,2"x47,2" RCP







bianco



# Siena

Porcelánico  
Porcelain tile

Rectificado · Pulido  
Rectified · Polished

60x120 RCP / 75x150 RCP / 120x120 RCP  
23,6"x47,2" RCP / 29,5"x59" RCP / 47,2"x47,2" RCP

**PASTA BLANCA:** 33x100 RC  
**WHITE BODY:** 12,9"x39,4" RC

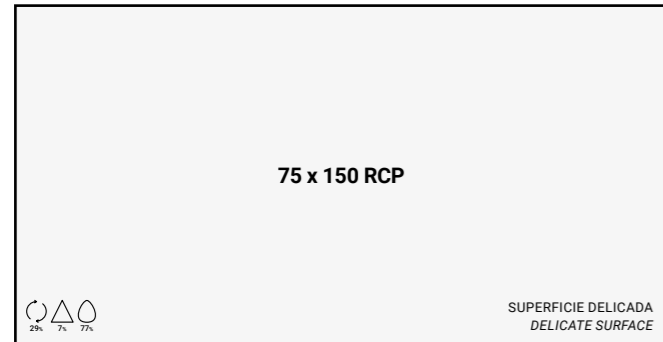
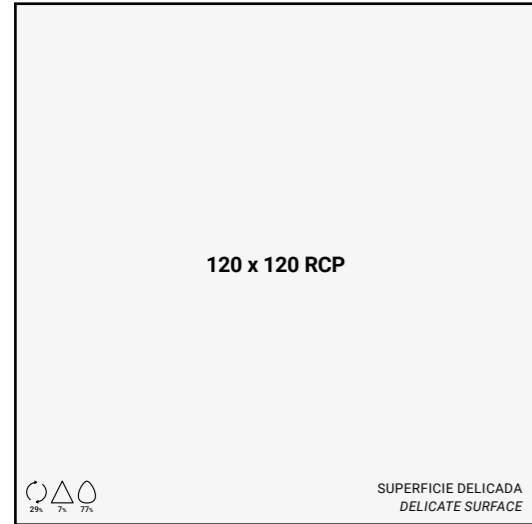
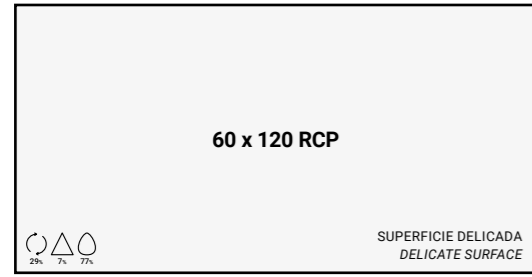

EJEMPLO DE VARIEDAD GRÁFICA  
GRAPHIC VARIETY EXAMPLE

SIENA BIANCO 120x120 RCP  
SIENA BIANCO 47,2"x 47,2" RCP



COMPLEMENTOS  
ACCESSORIES



BREEZE SIENA BIANCO  
33x100 RC / C230



VELVET SIENA BIANCO  
33x100 RC / C230

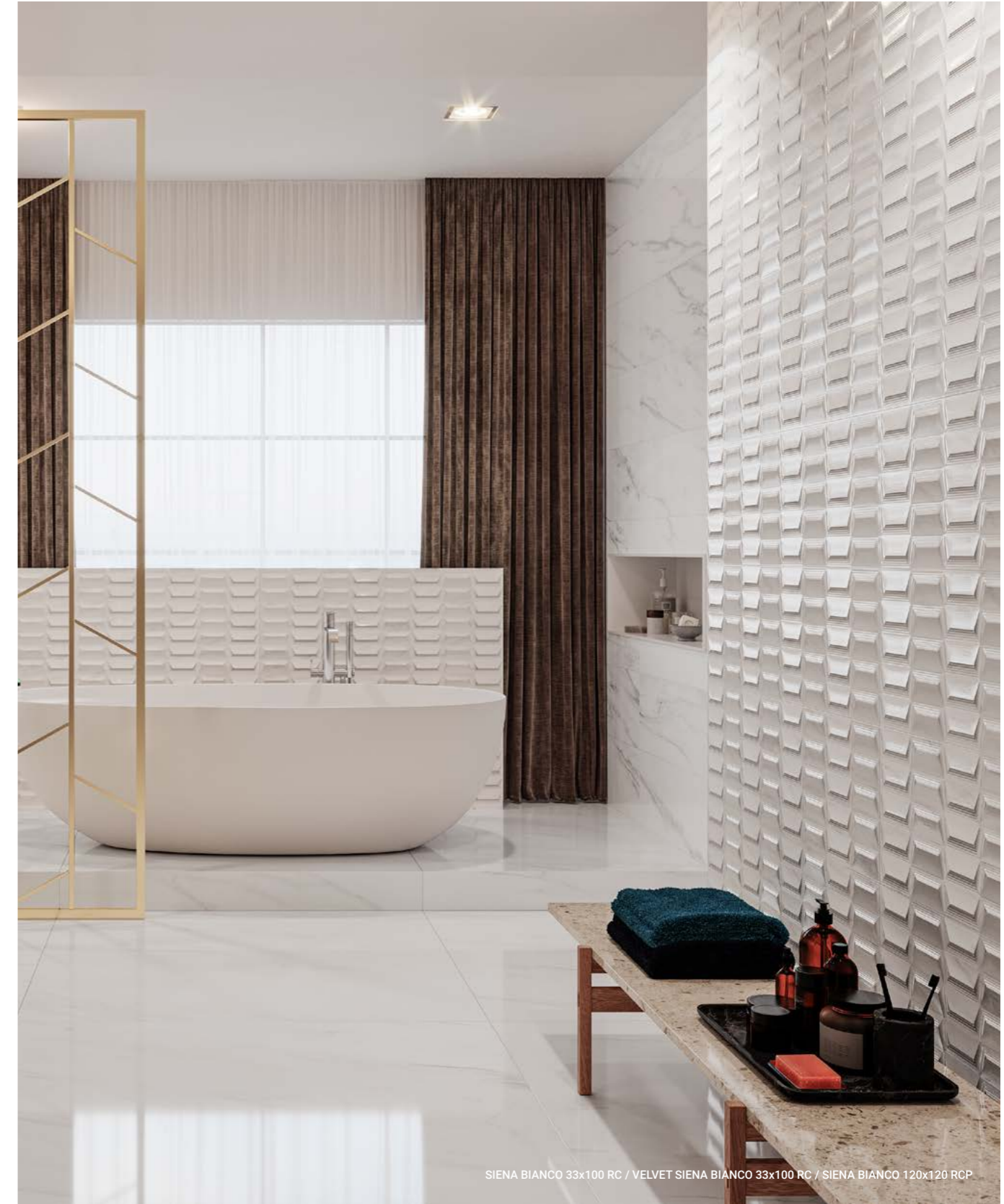

SIENA BIANCO 33x100 RC / VELVET SIENA BIANCO 33x100 RC / SIENA BIANCO 120x120 RCP



**COLOR**  
*COLOUR*

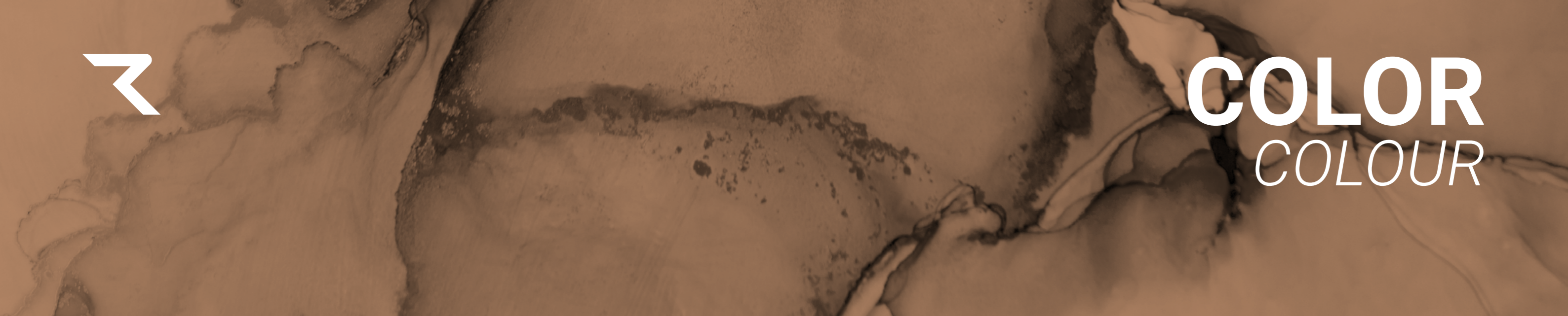

light-soft (lts)

smoke-soft (sks)

mink-soft (mks)



# Atmosphere

Porcelánico | Rectificado · Mate  
 Porcelain tile | Rectified · Matt

VIKER: 40x120 RC  
 VIKER: 15,7"x47,2" RC



ATMOSPHERE 7 LTS / B288  
 ATMOSPHERE 7 SKS / B288  
 ATMOSPHERE 7 MKS / B288



ATMOSPHERE 7 REL LTS  
40x120 RC / B310



ATMOSPHERE 7 REL SKS  
40x120 RC / B310



ATMOSPHERE 7 REL MKS  
40x120 RC / B310



ATMOSPHERE 7 MKS 40x120 RC

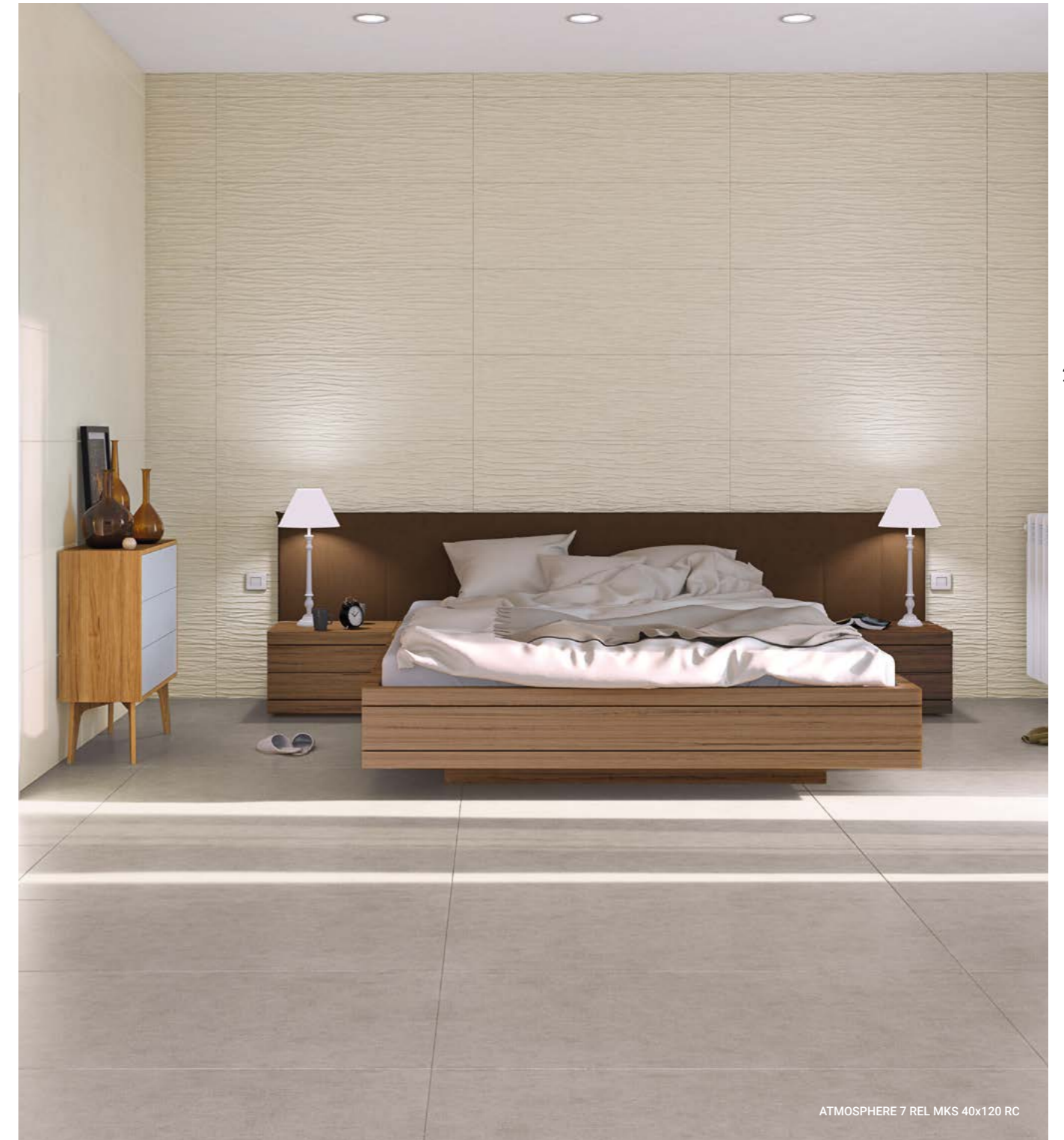

ATMOSPHERE 7 REL MKS 40x120 RC



ice

smoke

baltico

milk

rose

whale



# Bellezza

Revestimiento  
Wall tile

Brillo  
Gloss

**PORCELÁNICO:** 47,2x47,2  
**PORCELAIN TILE:** 18,6"x18,6"

**REVESTIMIENTO:** 20x60  
**WALL TILE:** 7,9"x23,6"



BELLEZZA ICE / B115  
BELLEZZA BALTICO / B115  
BELLEZZA ROSE / B115  
BELLEZZA SMOKE / B115  
BELLEZZA MILK / B115  
BELLEZZA WHALE / B115

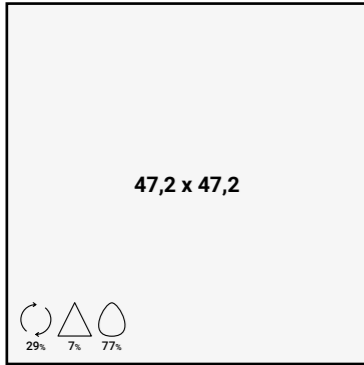

EJEMPLO DE VARIEDAD GRÁFICA  
GRAPHIC VARIETY EXAMPLE

BELLEZZA BALTICO 20X60 / BELLEZZA DEC COLD 47,2x47,2  
BELLEZZA BALTICO 7,9"x23,6" / BELLEZZA DEC COLD 18,6"x18,6"

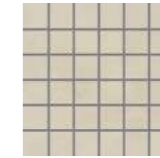
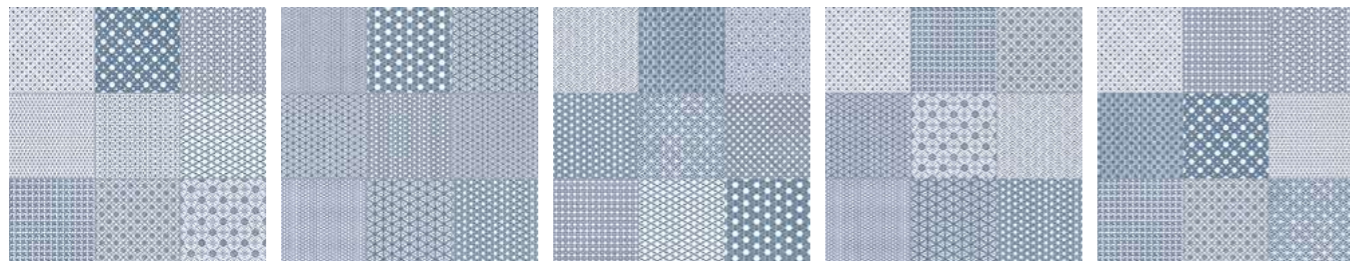
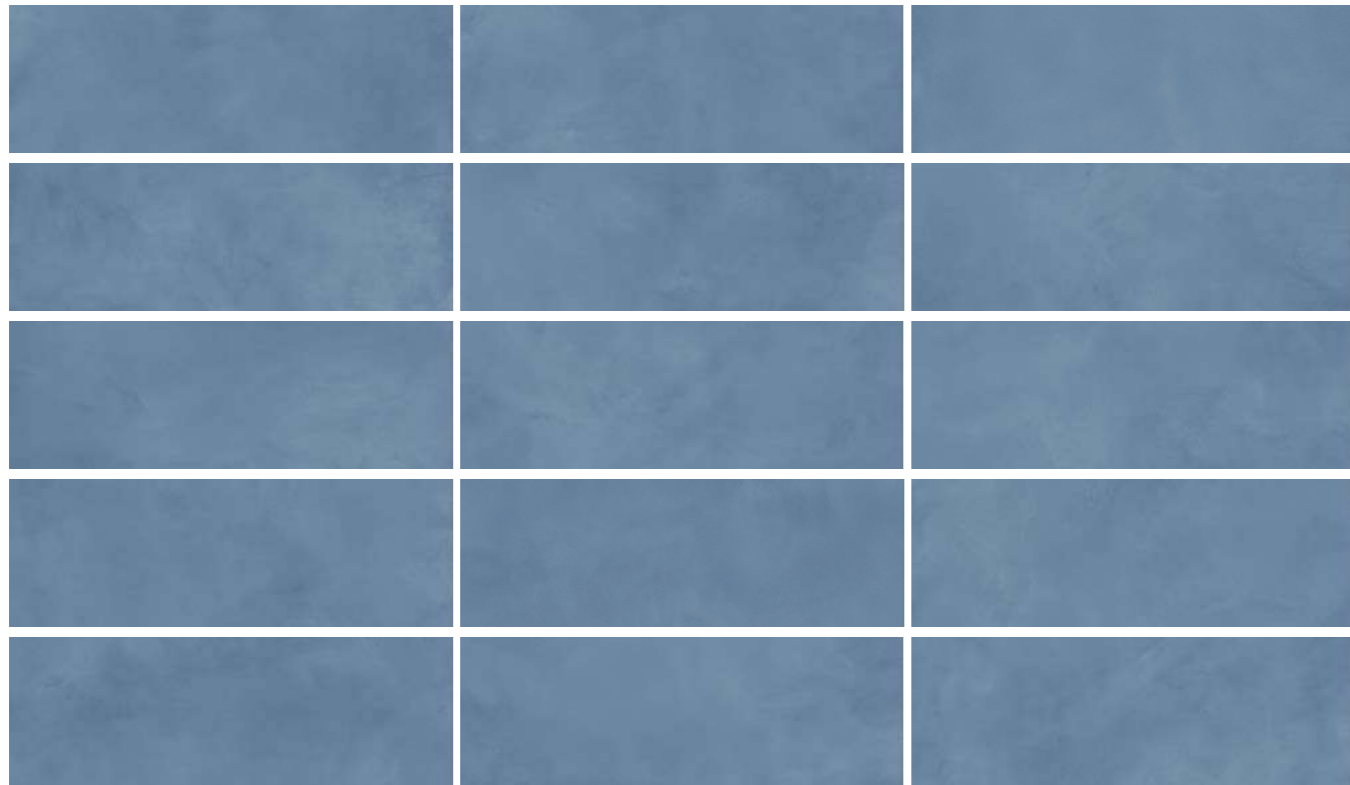

MS BELLEZZA SMOKE  
30x30 / C65

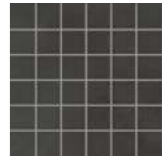

MS BELLEZZA WHALE  
30x30 / C65



BELLEZZA REL ICE  
20x60 / B138



BELLEZZA REL SMOKE  
20x60 / B138



BELLEZZA REL BALTICO  
20x60 / B138



BELLEZZA REL MILK  
20x60 / B138

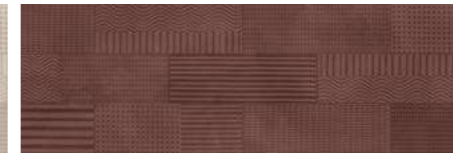

BELLEZZA REL ROSE  
20x60 / B138

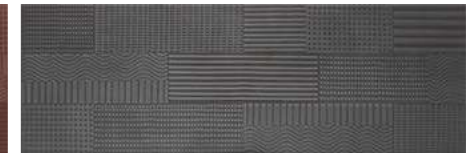

BELLEZZA REL WHALE  
20x60 / B138

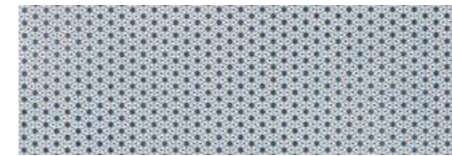

BELLEZZA DEC COLD  
20x60 / B138

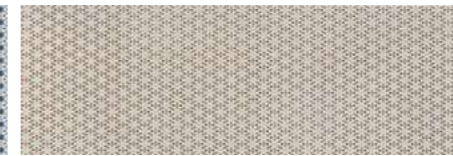

BELLEZZA DEC WARM  
20x60 / B138



BELLEZZA DEC IRIA  
20x60 / C142



BELLEZZA SMOKE  
47,2x47,2 / B186

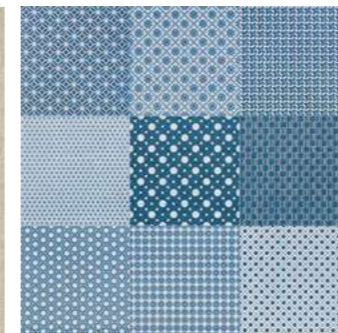

BELLEZZA DEC COLD  
47,2x47,2 / B207

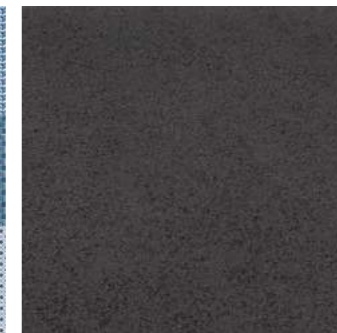

BELLEZZA WHALE  
47,2x47,2 / B186



BELLEZZA DEC WARM  
47,2x47,2 / B207



BELLEZZA BALTICO 20x60 / BELLEZZA DEC COLD 20x60



white

blue

rose

steel

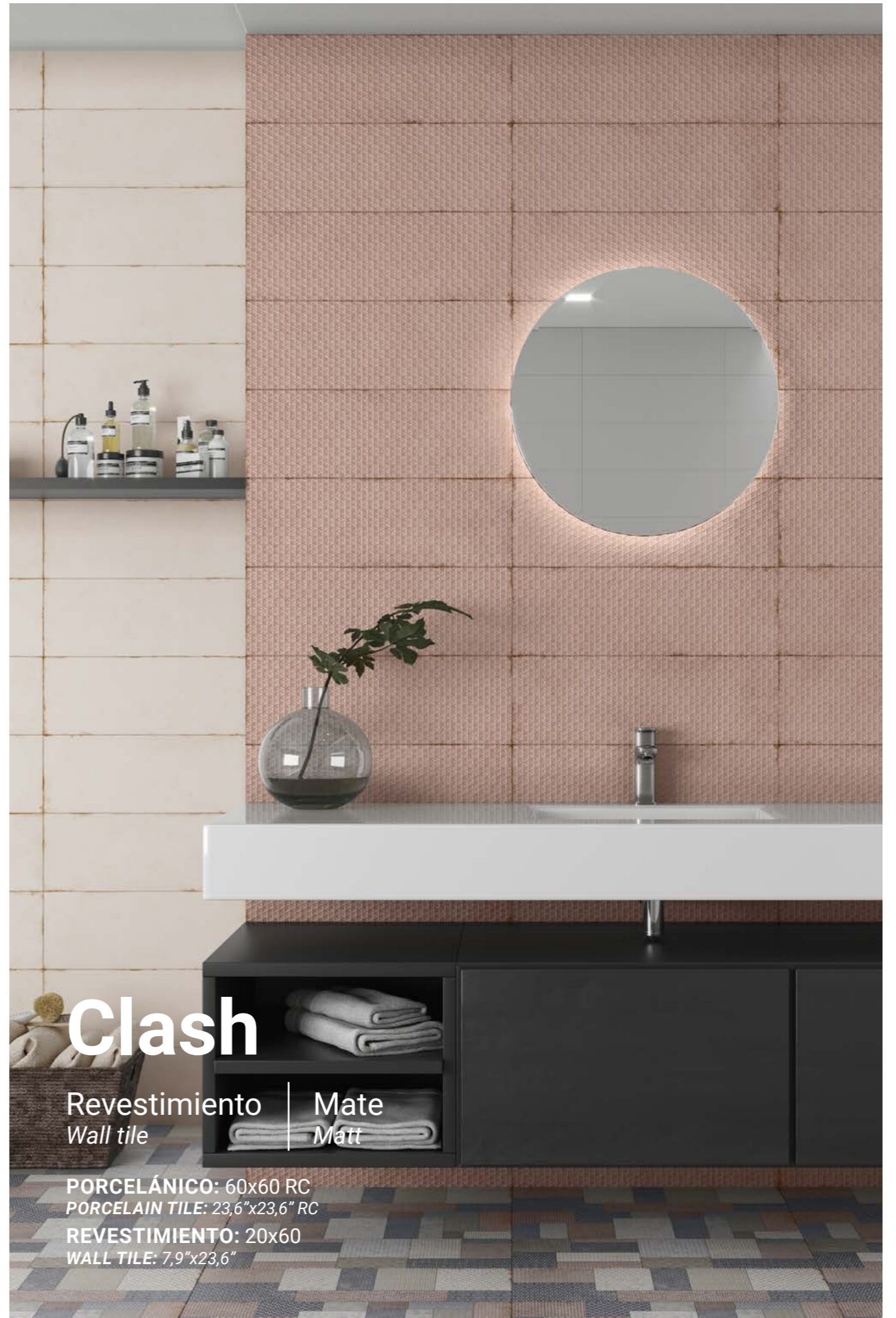

# Clash

Revestimiento | Mate  
 Wall tile | Matt

PORCELÁNICO: 60x60 RC  
 PORCELAIN TILE: 23,6"x23,6" RC  
 REVESTIMIENTO: 20x60  
 WALL TILE: 7,9"x23,6"





CLASH WHITE / B115  
CLASH BLUE / B115  
CLASH ROSE / B115  
CLASH STEEL / B115

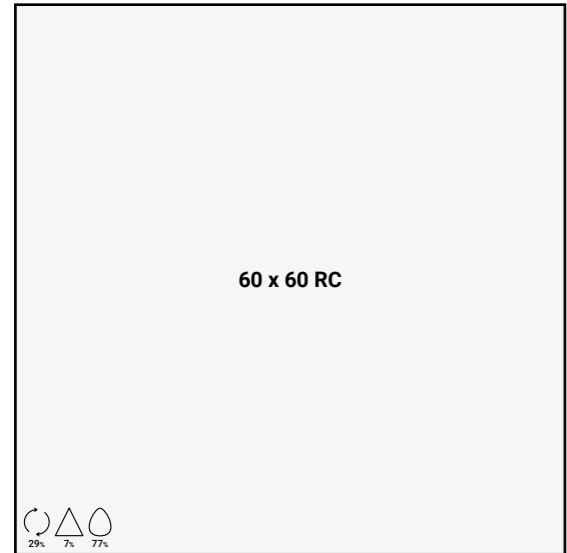

CLASH WHITE CTE2/R10/A / B226  
CLASH BLUE CTE2/R10/A / B226  
CLASH ROSE CTE2/R10/A / B226  
CLASH STEEL CTE2/R10/A / B226

EJEMPLO DE VARIEDAD GRÁFICA  
GRAPHIC VARIETY EXAMPLE

CLASH STEEL 20x60 / CLASH STEEL 60x60 RC  
CLASH STEEL 7,9"x23,6" / CLASH STEEL 23,6"x23,6"

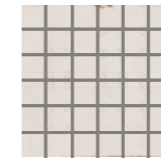

MS CLASH WHITE  
30x30 / C65

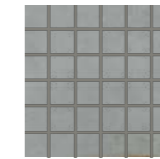

MS CLASH BLUE  
30x30 / C65

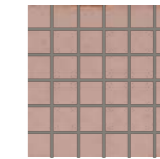

MS CLASH ROSE  
30x30 / C65

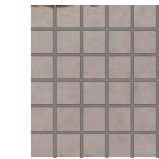

MS CLASH STEEL  
30x30 / C65



CLASH REL WHITE  
20x60 / B138



CLASH REL ROSE  
20x60 / B138



CLASH REL BLUE  
20x60 / B138

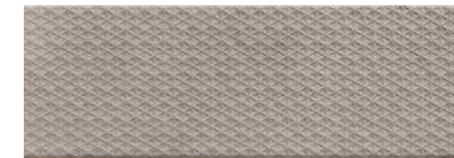

CLASH REL STEEL  
20x60 / B138



CLASH DEC COLD CTE2/R10/A  
60x60 RC / B226



CLASH DEC WARM  
20x60 / B138



CLASH DEC WARM  
20x60 / B138



DECOR STEEL BRICK COLD  
20x60 / C186



DECOR STEEL BRICK WARM  
20x60 / C186



CLASH DEC WARM CTE2/R10/A  
60x60 RC / B226



DECOR STEEL WOOD COLD  
20x60 / C186



DECOR STEEL WOOD WARM  
20x60 / C186



white

grey

blue

vison

sand

earth

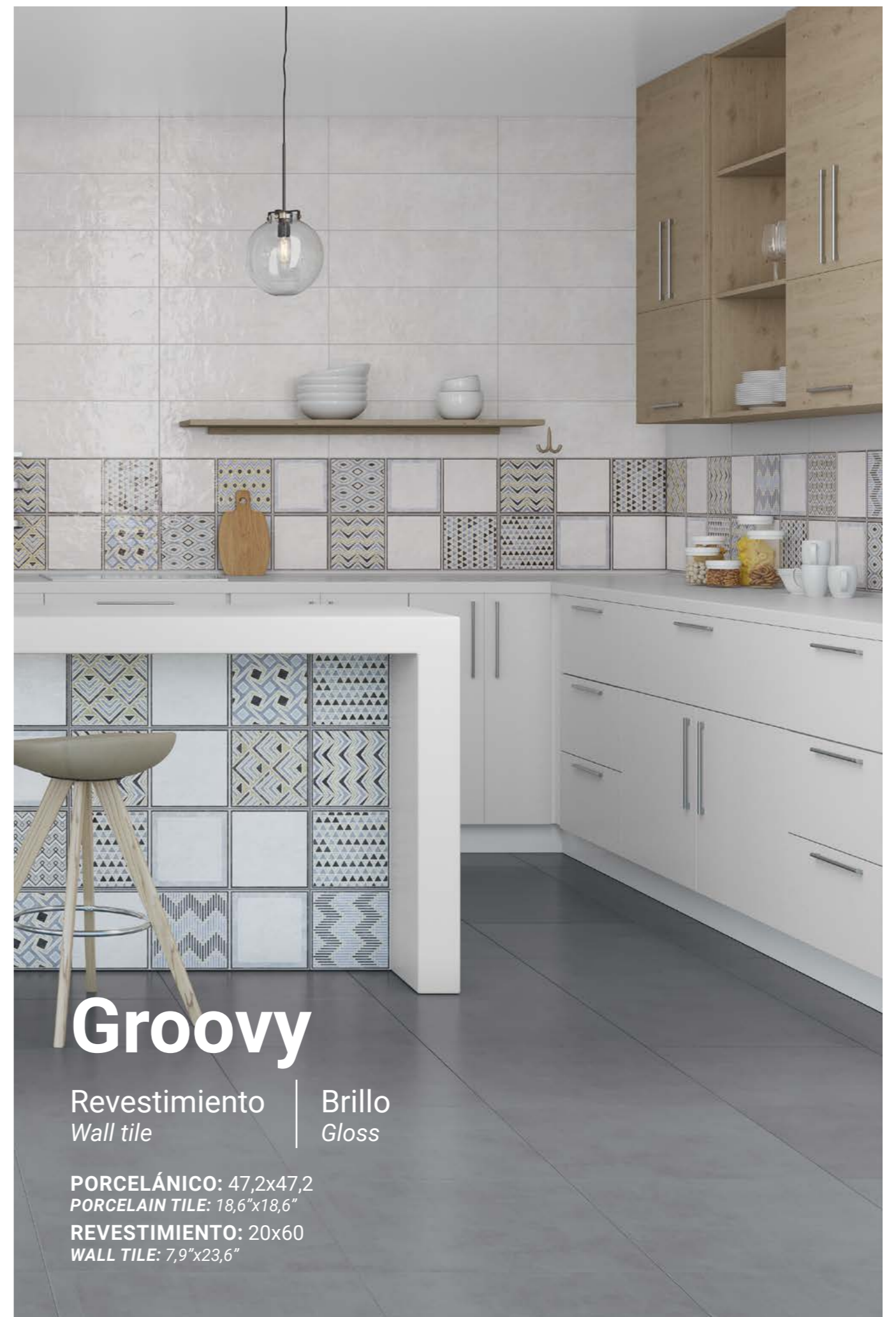

# Groovy

Revestimiento  
Wall tile

Brillo  
Gloss

PORCELÁNICO: 47,2x47,2  
PORCELAIN TILE: 18,6"x18,6"

REVESTIMIENTO: 20x60  
WALL TILE: 7,9"x23,6"



GROOVY WHITE / B115  
GROOVY VISON / B115  
GROOVY GREY / B115  
GROOVY SAND / B115  
GROOVY BLUE / B115  
GROOVY EARTH / B115

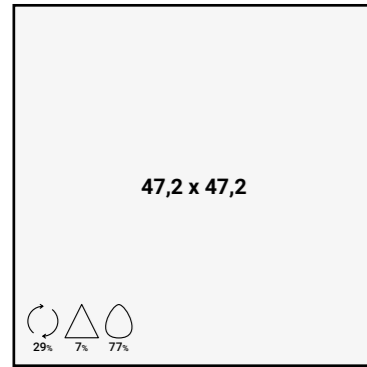

GROOVY GREY / B186  
GROOVY DEC COLD / B207  
GROOVY VISON / B186  
GROOVY DEC WARM / B207

EJEMPLO DE VARIEDAD GRÁFICA  
GRAPHIC VARIETY EXAMPLE

GROOVY GREY 20x60 / GROOVY REL GREY 20x60 / GROOVY DEC COLD 20x60  
GROOVY GREY 7,9"x23,6" / GROOVY REL GREY 7,9"x23,6" / GROOVY DEC COLD 7,9"x23,6"

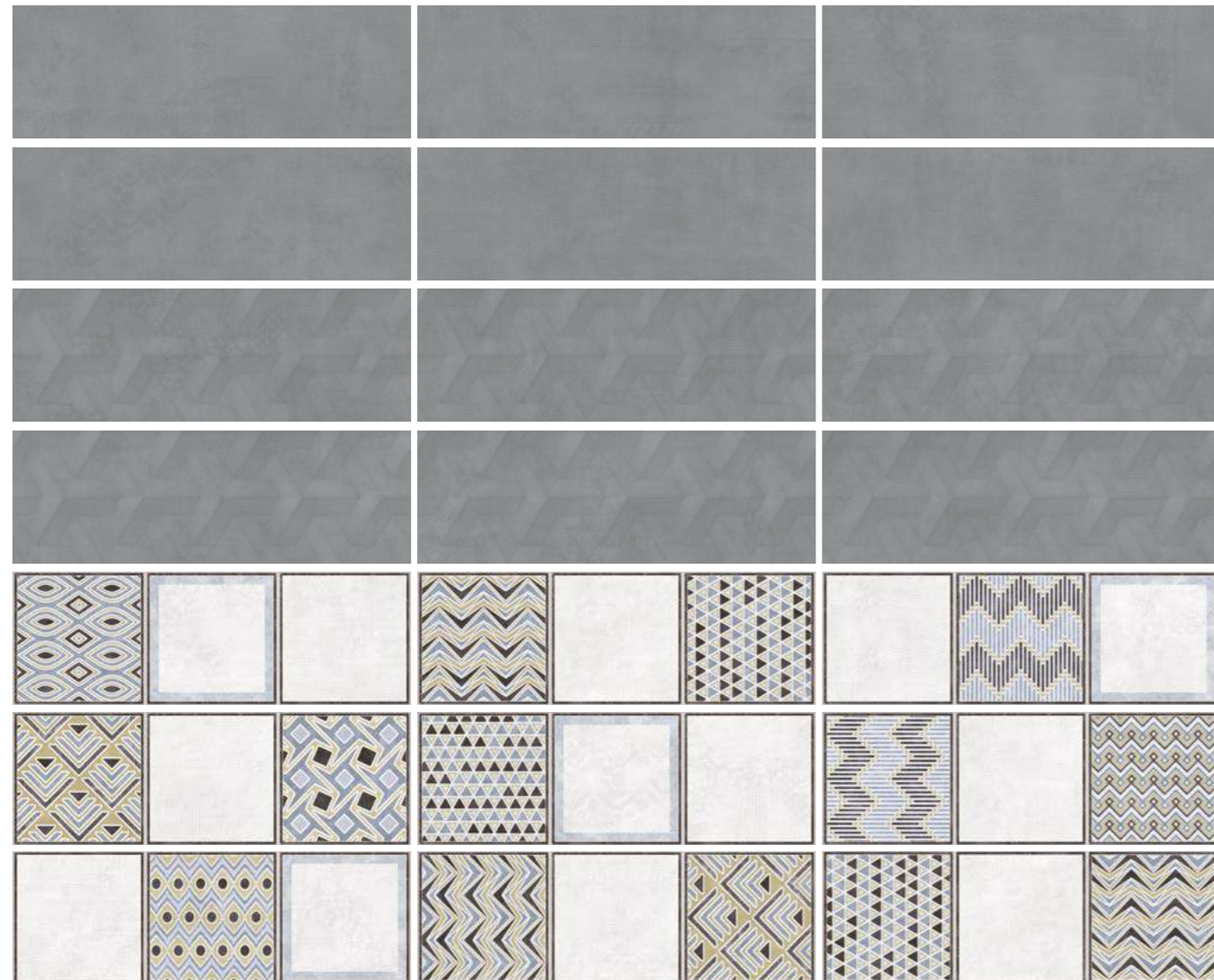

MS GROOVY VISON  
30x30 / C65

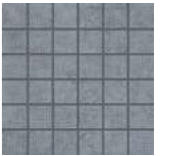

MS GROOVY GREY  
30x30 / C65



GROOVY REL WHITE  
20x60 / B138



GROOVY REL VISON  
20x60 / B138



GROOVY REL GREY  
20x60 / B138



GROOVY REL SAND  
20x60 / B138



GROOVY REL BLUE  
20x60 / B138



GROOVY REL EARTH  
20x60 / B138



GROOVY DEC COLD  
20x60 / B138



GROOVY DEC WARM  
20x60 / B138



DEC IRIA  
20x60 / C142



GROOVY GREY  
47,2x47,2 / B186



GROOVY DEC COLD  
47,2x47,2 / B 207



GROOVY VISON  
47,2x47,2 / B186



GROOVY DEC WARM  
47,2x47,2 / B207



GROOVY DEC WARM 47,2x47,2 / GROOVY REL VISON 20x60 / GROOVY EARTH 20x60 / GROOVY VISON 20x60

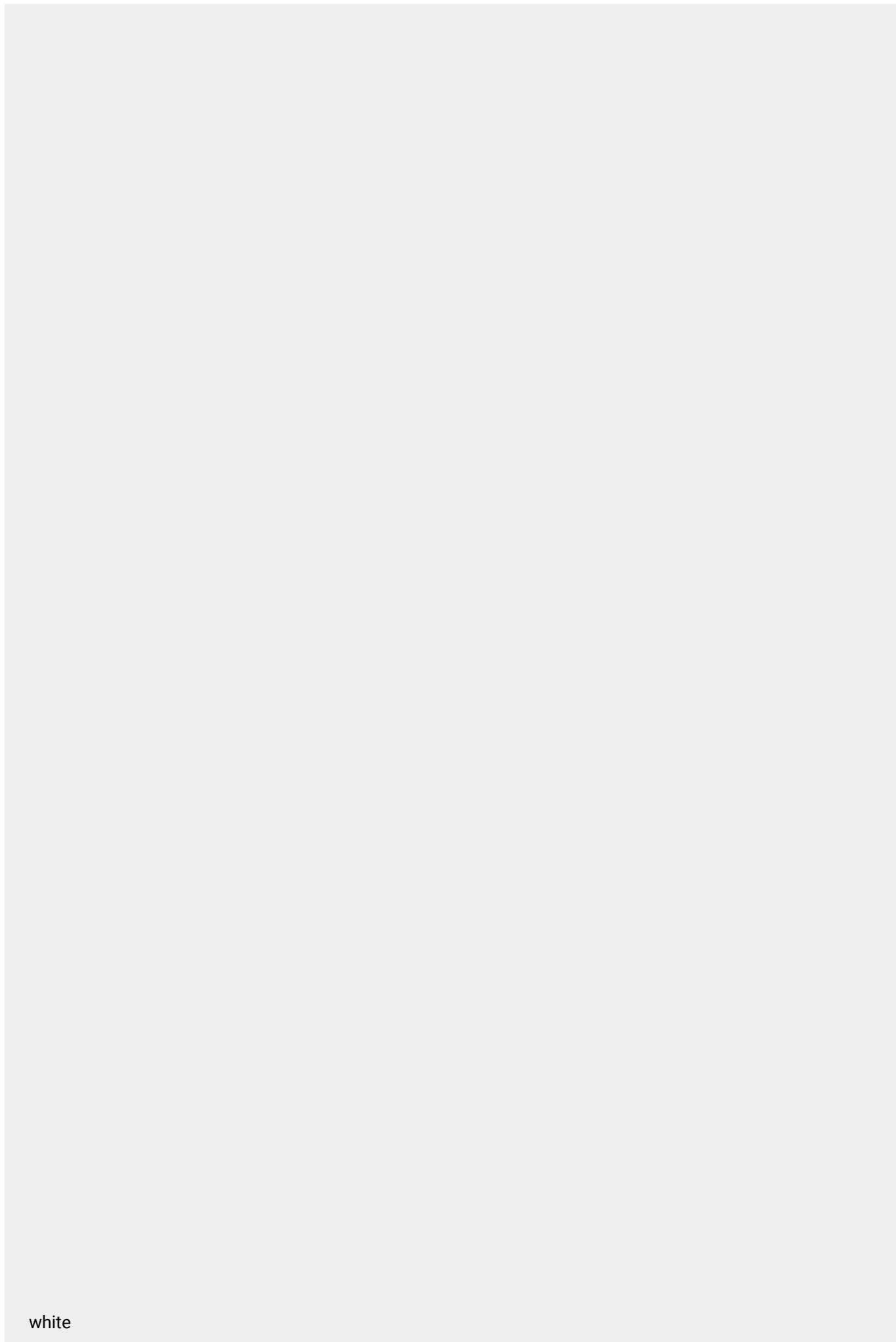

white

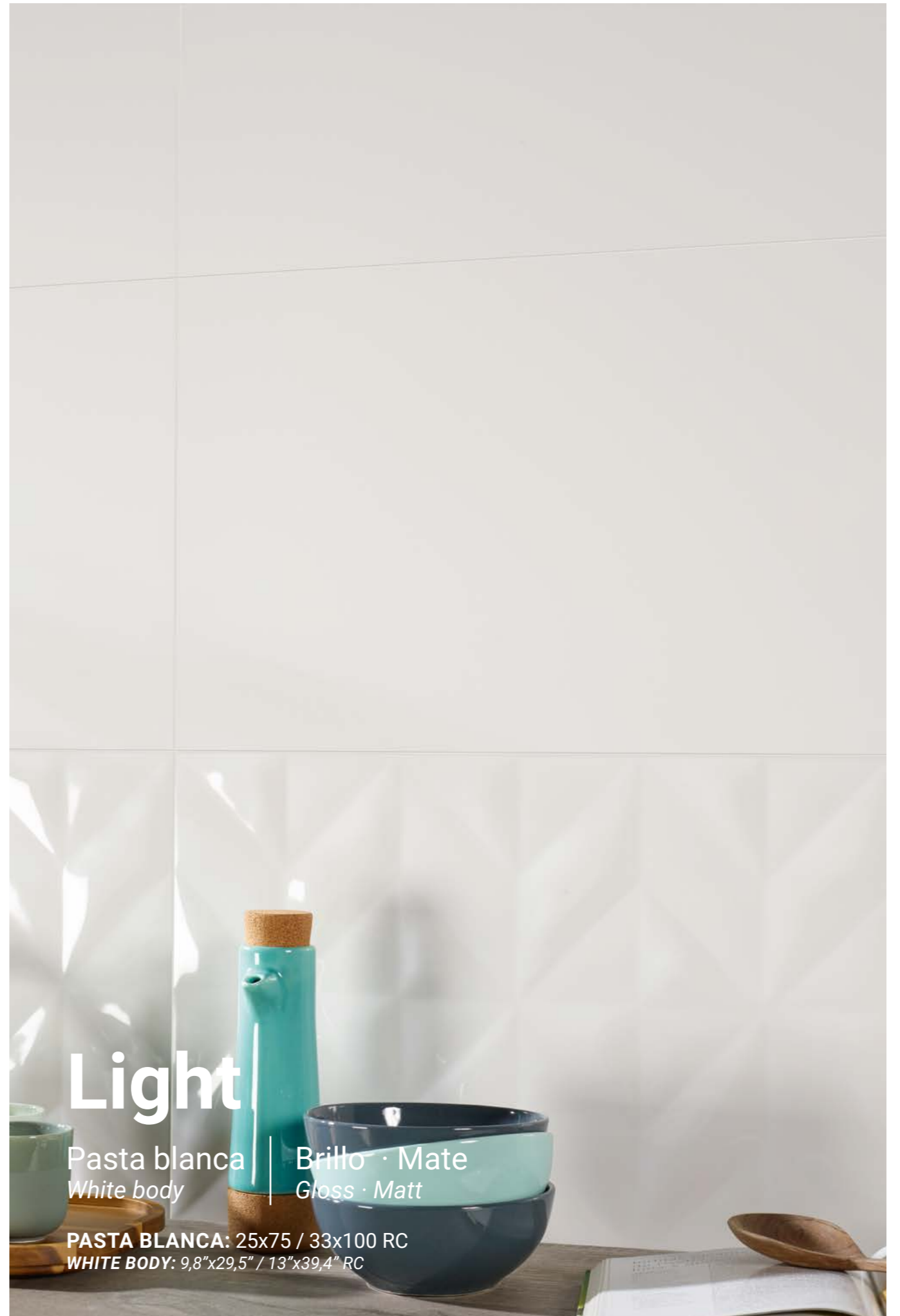

# Light

Pasta blanca | Brillo · Mate  
White body | Gloss · Matt

**PASTA BLANCA:** 25x75 / 33x100 RC  
**WHITE BODY:** 9,8"x29,5" / 13"x39,4" RC



LIGHT WHITE MATT / B149  
LIGHT WHITE GLOSS / B149



LIGHT WHITE MATT / B208  
LIGHT WHITE GLOSS / B208



LIGHT THEOS WHITE MATT  
25x75 / B166

LIGHT THEOS WHITE GLOSS  
25x75 / B166



LIGHT EIDOS WHITE MATT  
25x75 / B166

LIGHT EIDOS WHITE GLOSS  
25x75 / B166



LIGHT BIO WHITE MATT  
33x100 RC / B230

LIGHT BIO WHITE GLOSS  
33x100 / B230

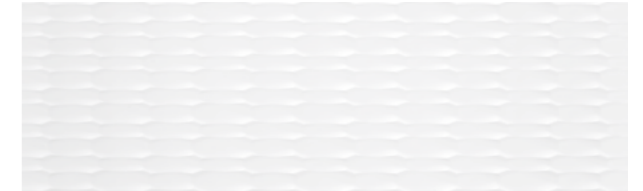

LIGHT EXA WHITE MATT  
33x100 RC / B230

LIGHT EXA WHITE GLOSS  
33x100 RC / B230



LIGHT-DEC BOSCO WHITE MATT A  
33x100 RC / C395

LIGHT-DEC BOSCO WHITE GLOSS A  
33x100 RC / C395



LIGHT-DEC BOSCO WHITE MATT B  
33x100 RC / C395

LIGHT-DEC BOSCO WHITE GLOSS B  
33x100 RC / C395



LIGHT-DEC SOFIA WHITE MATT A  
33x100 RC / C395



LIGHT-DEC SOFIA WHITE MATT B  
33x100 RC / C395



LIGHT-DEC SOFIA WHITE GLOSS A  
33x100 RC / C395



LIGHT-DEC SOFIA WHITE GLOSS B  
33x100 RC / C395

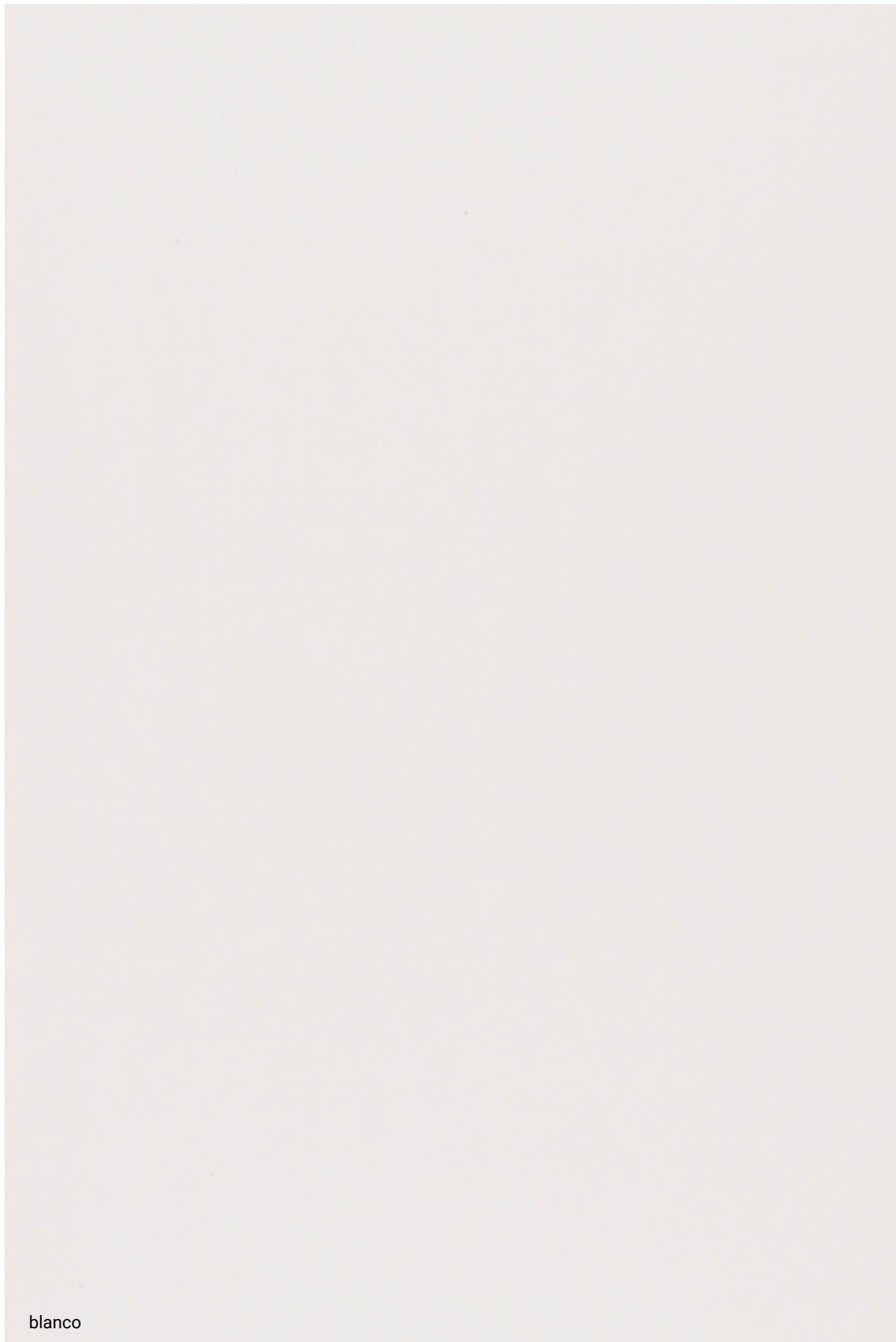

blanco

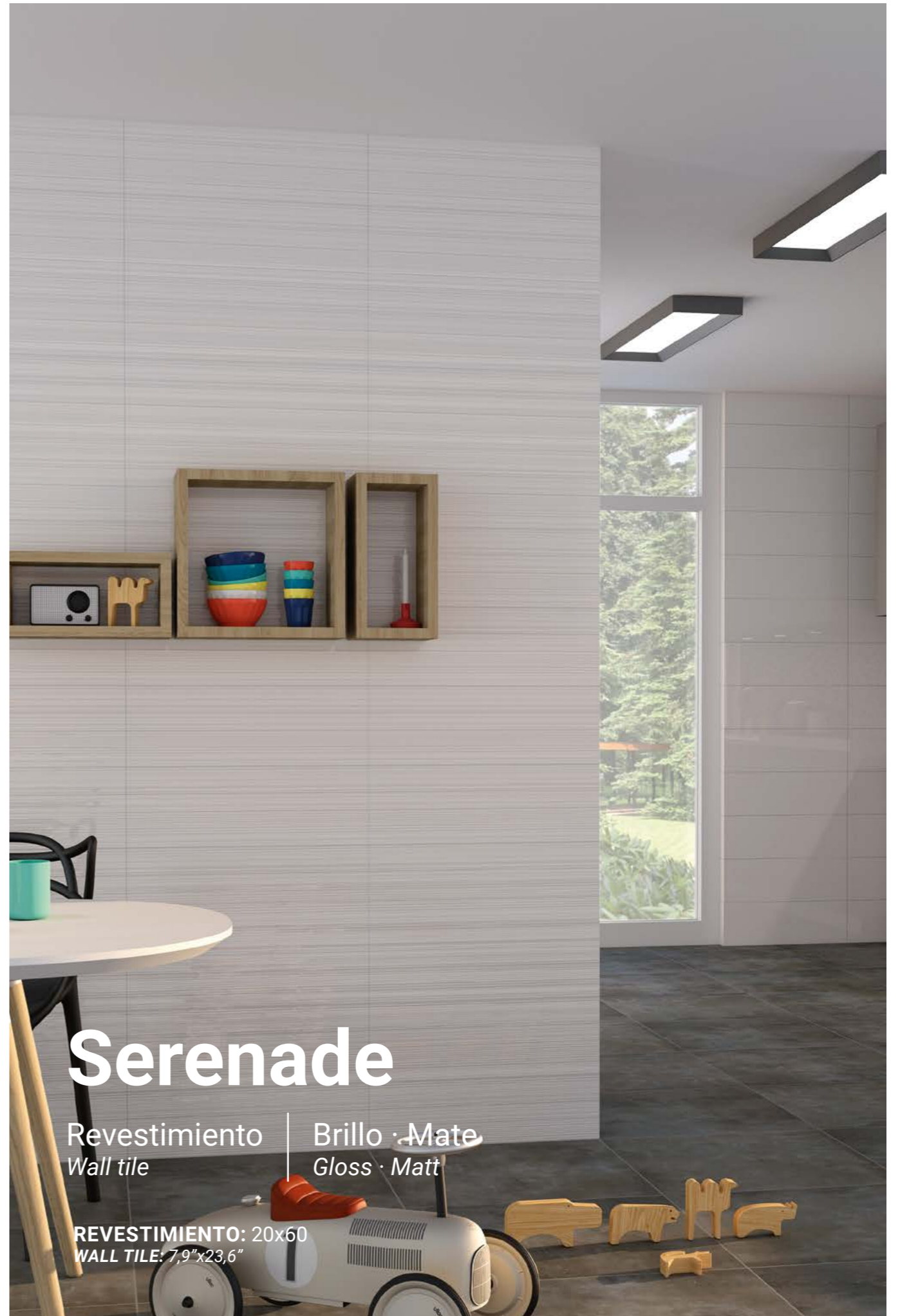

# Serenade

Revestimiento  
Wall tile

Brillo · Mate  
Gloss · Matt

REVESTIMIENTO: 20x60  
WALL TILE: 7,9"x23,6"



SERENADE-MATE BLANCO / B115  
SERENADE-BRILLO BLANCO / B115



SERENADE-4 MATE BLANCO  
20x60 / B138

SERENADE-2 BRILLO BLANCO  
20x60 / B138

SERENADE-2 MATE BLANCO  
20x60 / B138

ML ORO / 0,8x60 / C43

ML BRONCE / 0,8x60 / C43

ML PLATA / 0,8x60 / C40

VA INOX-BRILLO PLATA / 1,5x75 / C45

VA INOX-MATE PLATA / 1,5x75 / C45



SERENADE BRILLO BLANCO 20x60 / SERENADE-2 BRILLO BLANCO 20x60

# **Información técnica**

*Technical information*





### 1. CARACTERISTICAS.

Viker, un gres porcelánico que deja patente el encanto del mármol, del cemento y de la piedra natural.

Las posibilidades compositivas de Viker se multiplican con sus relieves y decorados en formato de 40x120cm en 7mm de grosor.

Esos criterios técnicos y estéticos hacen de este gres porcelánico un material perfecto para llevar a cabo con éxito los mayores retos arquitectónicos que se presenten y adaptarse a cualquier necesidad.

### 2. VENTAJAS.

Viker ofrece numerosas ventajas respecto a otros materiales naturales que se han utilizado tradicionalmente.

- No tiene absorción de agua.
- Anti-hielo e ignífugo.
- Resiste a los ataques químicos.
- Alta resistencia a agentes químicos y atmosféricos.
- No le afectan ni el moho ni el musgo.
- Viene perfectamente calibrado y con un espesor uniforme.
- Se limpia fácilmente.
- Se mantiene inalterable en el tiempo, tanto sus colores como sus características técnicas.
- Permite un mejor desarrollo estético.
- Permite la continuidad del mismo pavimento tanto en el interior como en el exterior.
- No absorbe y se limpia fácilmente.
- Al tener un menor espesor tiene menos peso, por lo que es más manejable, manteniendo una elevada resistencia a la carga de rotura.

### 3. TIPO DE COLOCACIÓN.

#### Tradicional

Para este tipo de instalación, utilizamos cemento exclusivo para cerámica. Una vez colocadas, las baldosas están completamente fijadas y no es posible moverlas.

Las ventajas de este tipo de colocación son las siguientes:

- Se puede rejuntar tanto en pavimento como en revestimiento.

#### Fachadas

El Viker es un material idóneo para instalar en fachadas debido a su baja absorción de agua. Estos son los tipos de sistema de fachadas con los que se puede instalar:

- Grapa vista.
- Anclaje encapsulado.
- Anclaje químico.

Las ventajas de este tipo de colocación son las siguientes:

- Aislamiento acústico.
- Aislamiento energético.
- Impermeabilidad.



### 1. CHARACTERISTICS.

Viker is a stoneware tile with all the charm of marble, of concrete and of natural stone.

The number in with Atmosphere tiles can be arranged is multiplied by relief and decoration in the 40x120cm format, in 7mm thick.

These technical and aesthetic criteria make this stoneware tile the perfect material to successfully meet the greatest architectural challenges that arise and adapt to any need.

### 2. ADVANTAGES.

Viker offers many advantages compared to other natural materials that have traditionally.

- Does not absorb water.
- Anti-icing and fireproof.
- High resistance to chemical and atmospheric agents.
- Resistant to chemical attacks.
- Not affected by mould or moss.
- It comes perfectly calibrated and its thickness is uniform.
- Easy to clean.
- Remains unaltered over time, both in colour and technical characteristics.
- Allows for a better aesthetic development.
- Allows the continuity of the same flooring both inside and outside.
- Easy to clean and non-absorbent.
- It weighs less because it is not as thick, making it easier to handle, maintaining a high resistance to breaking load.

### 3. TYPE OF FIXING.

#### Traditional

For this type of installation special ceramic cements are used which leave the tiles permanently fixed and immovable.

The advantages of this type of fixing are:

- Can be grouted.

#### Façades

Porcelain is the ideal material for façades due to its low water absorption. Following are the types of suitable systems for tiling façades:

- Exposed clips.
- Encapsulated anchor.
- Chemical anchor.

The advantages of this type of fixing are:

- Acoustic insulation.
- Thermal insulation.
- Impermeability.



### 1. CARACTÉRISTIQUES.

Viker, un grès cérame qui révèle tout le charme du marbre, du ciment et la pierre naturelle.

Les possibilités de composition d'Atmosphere se multiplient avec ses reliefs et décorations en format de 40x120cm. en épaisseur de 7mm.

Grâce à ses qualités techniques et esthétiques, ce grès cérame est un matériau idéal pour relever les plus grands défis architecturaux et s'adapter à tous les contextes.

### 2. AVANTAGES.

Viker offre des nombreux avantages par rapport à d'autres matériaux naturels qui ont été utilisés traditionnellement.

- Pas d'absorption d'eau.
- Résistance aux attaques chimiques.
- Anti-glace et anti-feu.
- Haute résistance aux agents chimiques et atmosphériques.
- Il ne se voit pas affecté par la moisson.
- Il est livré avec une parfaite épaisseur uniforme calibrée.
- Facile à nettoyer.
- Il reste inaltérable au fil du temps, autant leurs couleurs que leurs caractéristiques techniques.
- Permet un meilleur développement esthétique.
- Permet la continuité de la chaussée à l'intérieur et à l'extérieur.
- Il n'absorbe pas les liquides et se nettoie facilement.
- Pourvu qu'il a une épaisseur plus petite, il est plus léger. Pour cela est plus facile à mettre en place, tout en conservant une haute résistance à la charge de rupture.

### 3. VERLEGUNGSTYP.

#### Traditionell

Mit dieser Verlegung werden spezielle Kleber für Keramik benutzt, wobei das Material vollkommen befestigt wird und die Stücke nicht mehr bewegt werden können.

Die Vorteile dieser Verlegung sind:

- Der Belag oder die Verkleidung können verfugt werden.

#### Fassaden

Das Feinsteinzeug ist ein ideales Material, um es an Fassaden zu verlegen, da es wenig Wasser aufnimmt. Diese sind die Fassadensysteme, auf die es verlegt werden kann:

- Sichtbare Klammern.
- Verdeckte Verankerung.
- Chemische Verankerung.

Die Vorteile dieser Verlegung sind:

- Schalldämmung.
- Energetische Dämmung.
- Wasserundurchlässigkeit.
- Isolation thermique.
- Imperméabilité.



### 1. EIGENSCHAFTEN.

Viker ist ein Feinsteinzeug, das die Schönheit des Marmors hervorhebt, von Zement und Natursteins.

Die Einsatzmöglichkeiten von Viker vervielfachen sich mit seinen Reliefs und Dekorationen mit einem Format von 40x120cm mit einer Dicke von 7mm.

Diese technische und ästhetische Eigenschaften machen aus diesem Feinsteinzeug ein ideales Material, um große architektonische Herausforderungen erfolgreich zu lösen und allen Anforderungen gewachsen zu sein.

### 2. VORTEILE.

Viker bietet zahlreiche Vorteile gegenüber anderen natürlichen Materialien, die traditionell.

- Keine Wasseraufnahme.
- Beständig gegen Chemikalien.
- Frostsicher und feuerbeständig.
- Große Widerstandsfähigkeit gegen Chemikalien und wetterbedingte Einwirkungen.
- Leidet nicht unter Moos oder Insekten.
- Sie sind perfekt kalibriert und haben eine einheitliche Höhe.
- Die Reinigung ist einfach.
- Sowohl die Farben als auch die technischen Eigenschaften bleiben im Laufe der Zeit unverändert.
- Ermöglicht eine bessere Ästhetik.
- Ermöglicht die Weiterführung des gleichen Bodens in Innen- und Außenbereichen.
- Es nimmt keine Stoffe auf und lässt sich leicht reinigen.
- Dank der niedrigeren Höhe und Gewicht sind die Fliesen leichter zu handhaben, behalten aber eine hohe Druckfestigkeit.

### 3. TYPE DE POSE.

#### Traditionnelle

Pour ce type de pose, on utilise du ciment conçu spécialement pour la céramique. Une fois posés, les carreaux sont entièrement fixés et il n'est pas possible de les déplacer.

Voici les avantages de ce type de pose :

- Permet le jointoiement du revêtement de sol ou de mur.

#### Façades

Grâce à une faible absorption d'eau, le grès cérame est un matériau idéal pour les façades. Les systèmes d'installation des façades sont les suivantes :

- Agrafe apparente.
- Ancrage encapsulé.
- Ancrage chimique.

Voici les avantages de ce type de pose :

- Isolation acoustique.
- Isolation thermique.
- Imperméabilité.



## 1. CARACTERISTICAS.

OUTDOOR20 es un gres porcelánico de 20mm de espesor especialmente ideado para su uso en exterior. Su elevada resistencia a la carga de rotura y las tensiones, así como sus extraordinarias prestaciones antideslizantes, hacen de OUTDOOR20 el gres ideal para ambientes externos, tanto públicos como privados.

### DURABILIDAD ILIMITADA

- Anti-hielo e ignífugo.
- Alta resistencia a agentes químicos y atmosféricos.
- No le afectan ni el musgo ni los insectos.
- Fácil limpieza y mantenimiento.

## 2. VENTAJAS.

OUTDOOR20 ofrece numerosas ventajas respecto a otros materiales naturales que se han utilizado tradicionalmente en exterior.

- No tiene absorción de agua.
- Resiste a los ataques químicos.
- Resiste a la sal que se echa en el suelo para el hielo.
- No le afectan ni el moho ni el musgo.
- Viene perfectamente calibrado y con un espesor uniforme.
- Se limpia fácilmente.
- Se mantiene inalterable en el tiempo, tanto sus colores como sus características técnicas.
- Permite un mejor desarrollo estético.
- Permite la continuidad del mismo pavimento tanto en el interior como en el exterior.
- No absorbe y se limpia fácilmente.
- Al tener un menor espesor tiene menos peso, por lo que es más manejable, manteniendo una elevada resistencia a la carga de rotura.

## 3. DÓNDE.

Su extraordinaria resistencia, su facilidad de instalación y su sofisticado diseño permiten la colocación de OUTDOOR20 en prácticamente cualquier espacio exterior y ¿por qué no? interior. La imaginación es el límite.

### ÁMBITO DOMÉSTICO

- Jardines
- Terrazas
- Pasadizos
- Muros
- Patios
- Escaleras
- Piscinas
- Garaje

### ESPACIOS PÚBLICOS

- Hoteles (zonas comunes, piscinas, terrazas, etc.).
- Balnearios.
- Áreas residenciales.
- Áreas industriales.
- Pavimento urbano.
- Playas (sobre arena).
- Zonas con tráfico rodado leve (sobre baldosas colocadas, sistema tradicional).



## 1. CHARACTERISTICS.

OUTDOOR20 is a 20mm thick porcelain stoneware tile especially designed for outdoor use. Its high resistance to breaking load and stress, as well as its extraordinary slip-resistant features, make OUTDOOR20 an ideal tile for outdoor areas, both public and private.

### UNLIMITED DURABILITY

- Anti-icing and fireproof.
- High resistance to chemical and atmospheric agents.
- Not affected by moss or insects.
- Easy to maintain and clean.

## 2. ADVANTAGES.

OUTDOOR20 offers many advantages compared to other natural materials that have traditionally been used outdoors.

### COMPARED TO NATURAL-STONE

- Does not absorb water.
- Resistant to chemical attacks.
- Resistant to the salt used for melting ice.
- Not affected by mould or moss.
- It comes perfectly calibrated and its thickness is uniform.
- Easy to clean.
- Remains unaltered over time, both in colour and technical characteristics.
- Allows for a better aesthetic development.
- Allows the continuity of the same flooring both inside and outside.
- Easy to clean and non-absorbent.
- It weighs less because it is not as thick, making it easier to handle, maintaining a high resistance to breaking load.

## 3. WHERE.

Its extraordinary resistance, easy installation and sophisticated design mean that OUTDOOR 20 can be installed in practically any exterior and, why not? interior space. Imagination is the limit.

### IN THE HOME

- Gardens
- Stairs
- Walls
- Courtyards
- Passageways
- Garage
- Terraces
- Pools

### PUBLIC SPACES

- Hotels (communal areas, pools, terraces, etc.).
- Spas.
- Residential areas.
- Industrial areas.
- Urban paving.
- Beaches (over sand).
- Areas with mild road traffic (over paving stones installed, traditional system).



## 1. CARACTÉRISTIQUES.

OUTDOOR20 est un grès cérame de 20mm d'épaisseur spécialement conçu pour son utilisation à l'extérieur. Il a été spécialement conçu pour une utilisation à l'extérieur. Sa haute résistance à la charge de rupture et de stress ainsi que ses performances anti-glisser extraordinaires, nous permettent dire que le grès cérame OUTDOOR20 est idéal pour les environnements extérieurs, soient-ils publics ou privés.

### DURABILITÉ ILLIMITÉE

- Anti-glace et anti-feu.
- Haute résistance aux agents chimiques et atmosphériques.
- Il ne se voit pas affecté par la mousse ni par les insectes.
- Nettoyage et entretien faciles.

## 2. AVANTAGES.

OUTDOOR20 offre des nombreux avantages par rapport à d'autres matériaux naturels qui ont été utilisés traditionnellement à l'extérieur.

- Pas d'absorption d'eau.
- Résistance aux attaques chimiques.
- Résistance au sel du déglaceage.
- Il ne se voit pas affecté par la moisson.
- Il est livré avec une parfaite épaisseur uniforme calibrée.
- Facile à nettoyer.
- Il reste inaltérable au fil du temps, autant leurs couleurs que leurs caractéristiques techniques.
- Permet un meilleur développement esthétique.
- Permet la continuité de la chaussée à l'intérieur et à l'extérieur.
- Il n'absorbe pas les liquides et se nettoie facilement.
- Pourvu qu'il a une épaisseur plus petite, il est plus léger. Pour cela est plus facile à mettre en place, tout en conservant une haute résistance à la charge de rupture.

## 3. OÙ.

Sa résistance extraordinaire, facilité de mise en place et son design permettent d'installer OUTDOOR20 dans pratiquement n'importe quel espace extérieur et, pourquoi pas, à l'intérieur. L'imagination n'a pas de limites.

### DOMAINE DOMESTIQUE

- Jardins
- Escaliers
- Murs
- Patios
- Passages
- Terrasses
- Piscines

### ESPACES PUBLICS

- Hôtels (foyer, piscines, terrasses, etc.).
- Spas.
- Zones piéton.
- Zones industrielles.
- Trottoirs.
- Plages (sur le sable).
- Zones à trafic léger (sur les carrelages mis avec un système traditionnel)



## 1. EIGENSCHAFTEN.

OUTDOOR20 ist eine Porzellankeramik mit einer Höhe von 20mm, die spezifisch für ihre Benutzung in Außenbereichen konzipiert worden ist. Ihre hohe Druckfestigkeit und Resistenz gegen Spannungen, als auch ihre außerordentliche Rutschfestigkeit, machen aus OUTDOOR20 die ideale Keramikfliese für öffentliche und private Außenbereiche.

### UNBEGRENZTE LEBENSDAUER

- Frostsicher und feuerbeständig.
- Große Widerstandsfähigkeit gegen Chemikalien und wetterbedingte Einwirkungen.
- Beständig gegen Moos und Insekten.
- Leichter Unterhalt und Reinigung.

## 2. VORTEILE.

Outdoor 20 bietet zahlreiche Vorteile gegenüber anderen natürlichen Materialien, die traditionell in Außenbereichen benutzt worden sind.

- Keine Wasseraufnahme.
- Beständig gegen Chemikalien.
- Beständig gegen Streusalz.
- Leidet nicht unter Moos oder Insekten.
- Sie sind perfekt kalibriert und haben eine einheitliche Höhe.
- Die Reinigung ist einfach.
- Sowohl die Farben als auch die technischen Eigenschaften bleiben im Laufe der Zeit unverändert.
- Ermöglicht eine bessere Ästhetik.
- Ermöglicht die Weiterführung des gleichen Bodens in Innen- und Außenbereichen.
- Es nimmt keine Stoffe auf und lässt sich leicht reinigen.
- Dank der niedrigeren Höhe und Gewicht sind die Fliesen leichter zu handhaben, behalten aber eine hohe Druckfestigkeit.

## 3. WO.

Ihre außerordentliche Widerstandsfähigkeit, die leichte Legung und ihr durchdachtes Design erlauben die Legung von Outdoor 20 in fast jedem Bereich im Freien oder, wieso nicht, im Inneren. Die Vorstellungskraft ist die einzige Grenze.

### IM HÄUSLICHEN BEREICH

- Gärten
- Treppen
- Mauern
- Höfe
- Gänge
- Terrassen
- Swimmingpools

### IM ÖFFENTLICHEN BEREICH

- Hotels.
- Bäder / Spas.
- Wohnanlagen.
- Industrieanlagen.
- Orte mit wenig Verkehr (mit der traditionellen Verlegung) • Areas with mild road traffic (over paving stones installed, traditional system).



4. PIEZA COMPLEMENTARIA



4. COMPLIMENTARY PIECE

± 7  
↓ mm

**RODAPIÉ CORTE**  
SKIRTING TILE

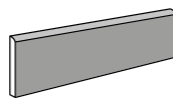

± 7  
↓ mm

FORMATO (AXL) SIZE (WXH)	CÓD. PRECIO PRICE CODE
8x60 RC	C62

± 10  
↓ mm



**BORDE RE**  
Borde con acabado romado y esmaltado en frío. Sin cocción.

**EDGE RE**  
Edge with blunt finish and cold enamelled. Unfired.



**BORDE ING**  
Borde con acabado ingletado.

**EDGE ING**  
Edge with mitred finish.

**RODAPIÉ CORTE**  
SKIRTING TILE (BULLNOSE)

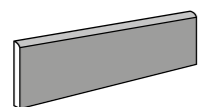

± 10  
↓ mm

FORMATO (AXL) SIZE (WXH)	CÓD. PRECIO PRICE CODE
8x60	C30

**PELDAÑO ÁNGULO ING**  
STAIR TREAD  
ANGLE MITRED BORDER

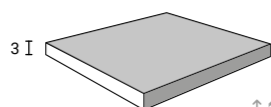

± 10  
↓ mm

FORMATO (AXL) SIZE (WXH)	CÓD. PRECIO PRICE CODE
31,6x60,8*	C583
30x60 RC*	C583
30x47,2*	C465
30x60*	C524
30x75 RC*	C645
22x90*	C630
30x90 RC*	C730
30x100 RC*	C790
19,4x120 RC*	C840
29,5x120 RC*	C1037

\* Lado derecho e izquierdo  
\* Right and left side

**PELDAÑO ING**  
MITRED STAIR TREAD

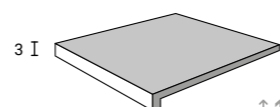

± 10  
↓ mm

FORMATO (AXL) SIZE (WXH)	CÓD. PRECIO PRICE CODE
31,6x60,8	C395
30x60 RC	C395
30x47,2	C298
30x60	C395
30x75 RC	C486
22x90	C558
30x90 RC	C610
30x100 RC	C695
19,4x120 RC	C750
29,5x120 RC	C780

± 20  
↓ mm



**BORDE RE**  
Borde con acabado romado y esmaltado en frío. Sin cocción.

**EDGE RE**  
Edge with blunt finish and cold enamelled. Unfired.



**BORDE ING**  
Borde con acabado ingletado.

**EDGE ING**  
Edge with mitred finish.

**BORDE RE**  
STAIR TREAD COPING TILE

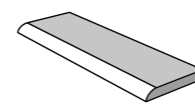

± 20  
↓ mm

FORMATO (AXL) SIZE (WXH)	CÓD. PRECIO PRICE CODE
20x60 RC	C149
20x61	C142
20x75 RC	C220
20x100 RC	C272
20x120 RC	C333

**BORDE ING**  
MITRED COPING TILE

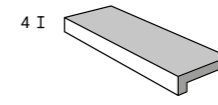

± 20  
↓ mm

FORMATO (AXL) SIZE (WXH)	CÓD. PRECIO PRICE CODE
20x60 RC	C583
20x61	C575
20x75 RC	C700
20x100 RC	C780
20x120 RC	C880

**FOCO HC**  
SPOTLIGHT HC

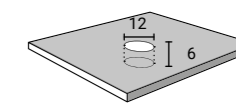

± 20  
↓ mm

FORMATO (AXL) SIZE (WXH)	CÓD. PRECIO PRICE CODE
61x61	C600
60x60 RC	C620
75x75 RC	C800
60x120 RC	C880
100x100 RC	C1037

Incluye base y foco led  
Includes base and led spotlight

**PELDAÑO RE**  
STAIR TREAD  
(GLAZED BULLNOSE)

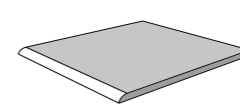

± 20  
↓ mm

FORMATO (AXL) SIZE (WXH)	CÓD. PRECIO PRICE CODE
30x60 RC	C149
30x100 RC	C316
29,5x120 RC	C375
60x60 RC	C264
100x100 RC	C716
60x120 RC	C575

**PELDAÑO ING**  
MITRED STAIR TREAD

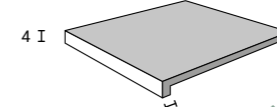

± 20  
↓ mm

FORMATO (AXL) SIZE (WXH)	CÓD. PRECIO PRICE CODE
30x60 RC	C499
30x100 RC	C770
29,5x120 RC	C1037
60x60 RC	C575
100x100 RC	C1250
60x120 RC	C1250

**PELDAÑO ÁNGULO RE**  
STAIR TREAD  
ANGLE BULLNOSE BORDER

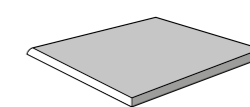

± 20  
↓ mm

FORMATO (AXL) SIZE (WXH)	CÓD. PRECIO PRICE CODE
30x30 RC	C129
30x60 RC*	C186
30x100 RC*	C354
29,5x120 RC*	C415
60x60 RC	C354
100x100 RC	C870
60x120 RC*	C524

\* Lado derecho e izquierdo  
\* Right and left side

**PELDAÑO ÁNGULO ING**  
STAIR TREAD  
ANGLE MITRED BORDER

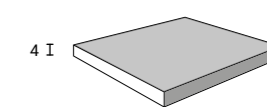

± 20  
↓ mm

FORMATO (AXL) SIZE (WXH)	CÓD. PRECIO PRICE CODE
30x30 RC	C660
30x60 RC*	C695
30x100 RC*	C1037
29,5x120 RC*	C1173
60x60 RC	C1037
100x100 RC	C2150
60x120 RC*	C1600

\* Lado derecho e izquierdo  
\* Right and left side

± 20  
mm



**BORDE RE**  
Borde con acabado romado y esmaltado en frío. Sin cocción.  
**EDGE RE**  
Edge with blunt finish and cold enamelled. Unfired.



**BORDE ING**  
Borde con acabado ingletado.  
**EDGE ING**  
Edge with mitered finish.

**REJILLA HC**  
POOL GRID  
(WATER-JET CUT)

± 20  
mm

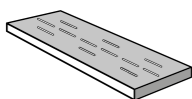

FORMATO (AXL) SIZE (WXH)	CÓD. PRECIO PRICE CODE
20x60 RC	C558

**BORDE ÁNGULO INTERIOR RE**  
STAIR TREAD COPING TILE  
(INNER CORNER)

± 20  
mm

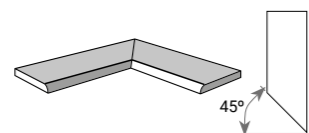

FORMATO (AXL) SIZE (WXH)	CÓD. PRECIO PRICE CODE
20x60 RC	C298

Juego de 2 piezas  
Set of 2 pieces

**BORDE ÁNGULO EXTERIOR RE**  
STAIR TREAD COPING TILE  
(OUTER CORNER)

± 20  
mm

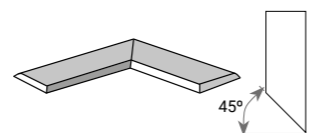

FORMATO (AXL) SIZE (WXH)	CÓD. PRECIO PRICE CODE
20x60 RC	C298

Juego de 2 piezas  
Set of 2 pieces

**REJILLA ÁNGULO HC**  
CORNER POOL GRID  
(WATER-JET CUT)

± 20  
mm

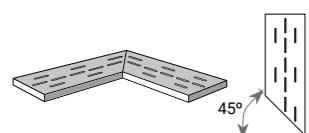

FORMATO (AXL) SIZE (WXH)	CÓD. PRECIO PRICE CODE
20x60 RC	C1300

Juego de 2 piezas  
Set of 2 pieces

**BORDE ÁNGULO INTERIOR ING**  
INKJET PRINTED COPING TILE  
(INNER CORNER)

± 20  
mm

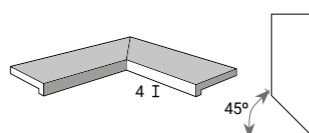

FORMATO (AXL) SIZE (WXH)	CÓD. PRECIO PRICE CODE
20x60 RC	C1173

Juego de 2 piezas  
Set of 2 pieces

**BORDE ÁNGULO EXTERIOR ING**  
INKJET PRINTED COPING TILE  
(OUTER CORNER)

± 20  
mm

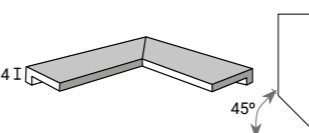

FORMATO (AXL) SIZE (WXH)	CÓD. PRECIO PRICE CODE
20x60 RC	C1173

Juego de 2 piezas  
Set of 2 pieces



1. CARACTERÍSTICAS TÉCNICAS
2. TABLA ANTIDESLIZANTES
3. EMBALAJE
4. TABLA DE ESPESORES



1. TECHNICAL CHARACTERISTICS
2. TABLE ANTI-SLIP
3. PACKAGING
4. TABLE OF THICKNESSES

Norma / NORM	Ensayo / TEST	ISO 13006 UNE-EN 14411	ROCERSA VALORES / VALUES
UNE-EN ISO 10545-2	Medida de longitud y de anchura Length and width	Desviación respecto del valor medio ± 0,5%	Desviación respecto del valor medio ± 0,2%
	Medida del grosor Thickness	Desviación respecto medida de fabricación ± 5%	Desviación respecto medida de fabricación ± 2%
	Medida de la rectitud de los lados Measurement of side straightness	Desviación respecto medida de fabricación ± 0,5%	Desviación respecto medida de fabricación ± 0,2%
	Medida de la ortogonalidad Squareness	Desviación respecto medida de fabricación ± 0,6%	Desviación respecto medida de fabricación ± 0,2%
	Medida de la planitud de la superficie Surface flatness	Desviación respecto medida de fabricación ± 0,5%	Desviación respecto medida de fabricación ± 0,2%
UNE-EN ISO 10545-3	Determinación de la absorción de agua Water absorption	Valor medio E ≤ 0,5%	Valor E ≤ 0,1%
UNE-EN ISO 10545-4	Módulos de rotura Modulus of rupture	Mínimo valor ≥ 35 N / mm <sup>2</sup>	Valor ≥ 40 N / mm <sup>2</sup>
	Fuerza de rotura Breaking strength	Espesor Thickness > 1.300 N	> 2.500 N
UNE-EN ISO 10545-6	Resistencia a la abrasión Resistance to abrasion	Según los valores del fabricante As per manufacturer	Según modelo Depending on model
UNE-EN ISO 10545-8	Determinación de la dilatación térmica lineal Thermal expansion coefficient	Método de ensayo disponible Test method available	—
UNE-EN ISO 10545-12	Resistencia a la helada Frost resistance	Exigido Demanded	Cumple la norma Complies with the standards
UNE-EN ISO 10545-13	Resistencia a los ácidos y bases Resistance against acids and bases	Según los valores del fabricante As per manufacturer	GLB, GHB
		Clase/Class GB min	Cumple la norma Complies with the standards
UNE-EN ISO 10545-14	Resistencia a las manchas Resistance to staining	Clase/Class 3 min	Cumple la norma Complies with the standards

Norma / NORM	Ensayo / TEST	ISO 13006 UNE-EN 14411	ROCERSA VALORES / VALUES
UNE-EN ISO 10545-2	Medida de longitud y de anchura Length and width	Desviación respecto del valor medio ± 0,5%	Cumple la norma Complies with the standards
	Medida del grosor Thickness	Desviación respecto medida de fabricación ± 0,5%	Cumple la norma Complies with the standards
	Medida de la rectitud de los lados Measurement of side straightness	Desviación respecto medida de fabricación ± 0,5%	Cumple la norma Complies with the standards
	Medida de la ortogonalidad Squareness	Desviación respecto medida de fabricación ± 0,5%	Cumple la norma Complies with the standards
	Medida de la planitud de la superficie Surface flatness	Desviación respecto medida de fabricación ± 0,5%	Cumple la norma Complies with the standards
UNE-EN ISO 10545-3	Determinación de la absorción de agua Water absorption	Valor medio %	Valor E ≤ 0,5%
UNE-EN ISO 10545-4	Módulos de rotura Modulus of rupture	Fuerza de rotura N	Valor 1800 - 2400 N
		Fuerza de rotura Breaking strength	Resistencia a la flexión Flexural strength Nm <sup>2</sup>
UNE-EN ISO 10545-6	Resistencia a la abrasión Resistance to abrasion	Abrasión profunda mm <sup>3</sup> Deep abrasion mm <sup>3</sup>	<130 mm <sup>3</sup>
UNE-EN ISO 10545-8	Determinación de la dilatación térmica lineal Thermal expansion coefficient	Método de ensayo disponible Test method available	< 7,0 x 10 <sup>-6</sup> °C
UNE-EN ISO 10545-12	Resistencia a la helada Frost resistance	Exigido Demanded	Cumple la norma Complies with the standards
UNE-EN ISO 10545-13	Resistencia a los ácidos y bases Resistance against acids and bases	Cloruro amónico 100 g/l Hipoclorito sódico 20 mg/l	GA
		Ácido clorídrico 3% Ácido cítrico 100g/l Hidróxido potásico 30 g/l	Cumple la norma Complies with the standards
UNE-EN ISO 10545-14	Resistencia a las manchas Resistance to staining	Oxido verde en aceite ligero Green oxide in light oil Solución alcohólica de yodo Iodine alcohol solution Aceite de oliva Olive oil	5 5 5



5. PLOTS.



5. PLOTS.



5. PLOTS.



5. STELZLAGERN.

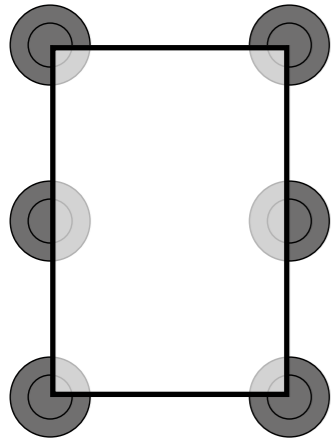

60x90cm RC ± 3,7 PLOTS / m<sup>2</sup>

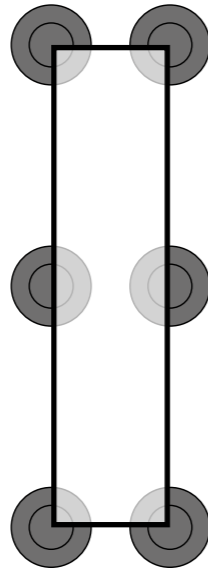

29,5x120cm RC ± 5,6 PLOTS / m<sup>2</sup>

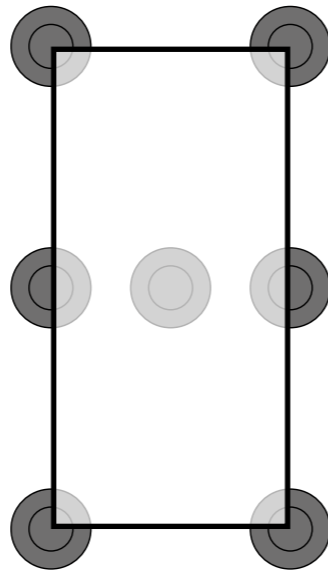

60x120cm RC ± 4,2 PLOTS / m<sup>2</sup>

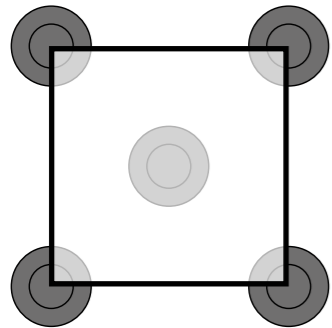

61x61 / 60x60cm RC ± 5,4 PLOTS / m<sup>2</sup>

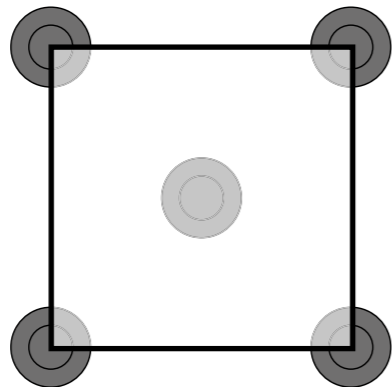

75x75cm RC ± 3,6 PLOTS / m<sup>2</sup>

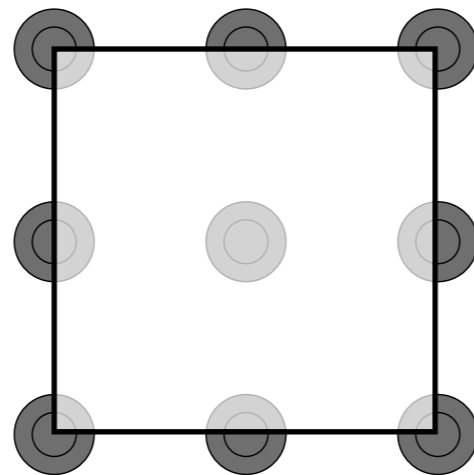

100x100cm RC ± 4 PLOTS / m<sup>2</sup>

REGULABLE  
REGULABLE  
REGULIERBAR  
REGULABLE

SP0 37-50mm

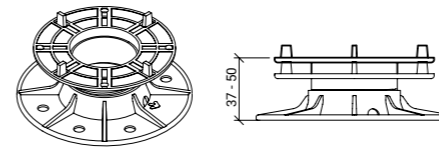

SP0 50-75mm

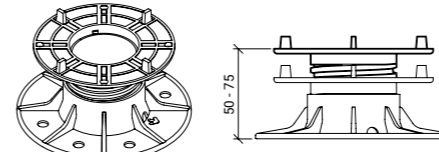

SP1 80-130mm

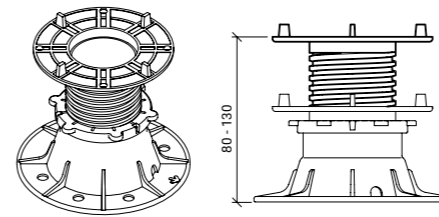

ALMOHADILLA  
PAD  
PADDLE  
COUSSIN

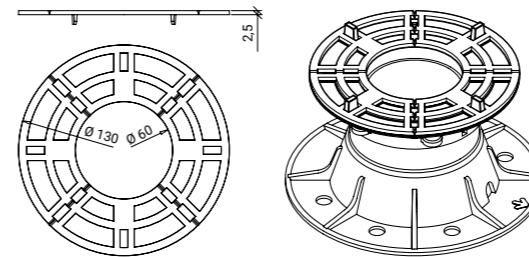

REGULADOR DE INCLINACIÓN  
INCLINE REGULATOR  
STEIGUNGSREGLER  
REGULATEUR INCLINE

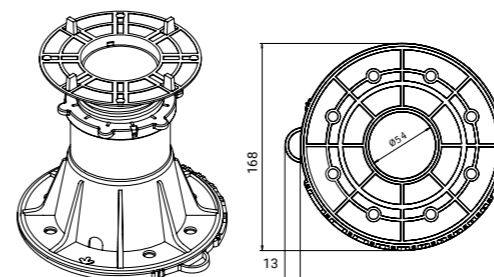

SP2 130-220mm

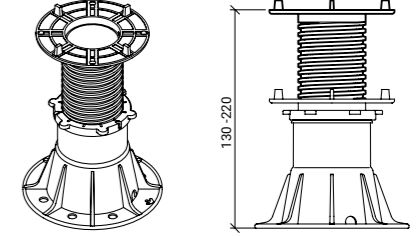

SP3 220-310mm

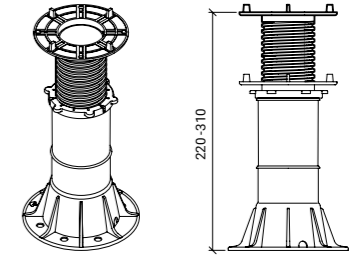

FIJO  
FIXED  
FESTER  
FIXÉ

10mm / 15mm

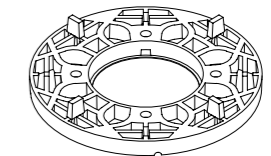
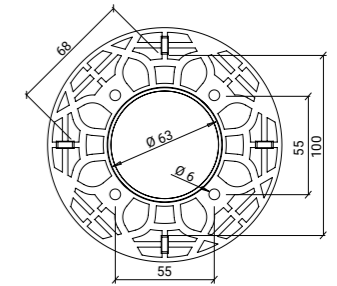

Apoyo fijo/ fixed 10mm

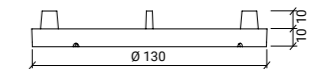

Apoyo fijo/ fixed 15mm

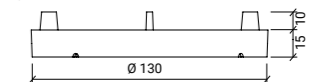

Formatos vigentes 2021: PORCELANICO Y GRES Current formats 2021: PORCELAIN AND FLOOR	CTE1	CTE2	CTE3	R9	R10	R11	A	B	C
<b>Arpegio</b>									
60x90 RC		●			●			●	
60x90_2 RC			●			●			●
<b>Axis</b>									
31,6x60,8		●	●		●	●		●	●
60x60 RC		●			●			●	
60x90 RC		●			●			●	
60x120 RC		●			●			●	
100x100 RC		●			●			●	
60x60_2 RC			●			●			●
60x120_2 RC			●			●			●
61x61_2			●			●			●
60x90_2 RC			●			●			●
100x100_2 RC			●			●			●
<b>Belfort</b>									
47,2x47,2	●			●			●		
60x60	●			●			●		
75x75 RC	●			●			●		
60x60_2 RC			●			●			●
75x75_2 RC			●			●			●
<b>Bellezza</b>									
47,2x47,2	●			●			●		
<b>Burlington</b>									
31,6x60,8	●			●			●		
47,2x47,2	●			●			●		
60x90 RC	●			●			●		
60x120 RC	●			●			●		
100x100 RC	●			●			●		
60x90_2 RC			●			●			●
100x100_2 RC			●			●			●
<b>Chrono</b>									
31,6x60,8	●			●			●		
47,2x47,2	●			●			●		
60x120 RC		●		●				●	
60x60_2 RC			●			●			●
60x120_2 RC			●			●			●
<b>Citadel</b>									
60x60 RC	●			●			●		
60x120 RC	●			●			●		
75x75 RC	●			●			●		
60x120_2 RC			●			●			●
75x75_2 RC			●			●			●
<b>Clash</b>									
60x60 RC		●		●			●		
<b>Concreto</b>									
60x120 RC	●		●	●		●	●		●
60x120_2 RC			●			●			●

Formatos vigentes 2021: PORCELANICO Y GRES Current formats 2021: PORCELAIN AND FLOOR	CTE1	CTE2	CTE3	R9	R10	R11	A	B	C
<b>Contract</b>									
60x120 RC		●			●			●	
60x120_2 RC			●			●			●
<b>Coralstone</b>									
31,6x60,8	●			●			●		
30x60 RC	●			●			●		
60x60 RC	●			●			●		
60x120 RC		●			●			●	
100x100 RC	●				●			●	
60x60_2 RC			●			●			●
60x90_2 RC			●			●			●
60x120_2 RC			●			●			●
100x100_2 RC			●			●			●
<b>Custom</b>									
22,5x90	●		●	●		●	●		●
<b>Dover</b>									
31,6x60,8	●		●	●		●	●		●
60x60 RC		●			●			●	
60x120 RC		●			●			●	
75x75 RC		●	●		●	●		●	●
100x100 RC		●			●			●	
60x60_2 RC			●			●			●
60x120_2 RC			●			●			●
75x75_2 RC			●			●			●
100x100_2 RC			●			●			●
<b>Eifel</b>									
31,6x60,8		●			●			●	
<b>Essential</b>									
60x60 RC	●			●			●		
<b>Eternal Stone</b>									
60x60 RC	●		●	●		●	●		●
60x120 RC	●			●			●		
100x100 RC	●		●	●		●	●		●
60x60_2 RC			●			●			●
100x100_2 RC			●			●			●
<b>Everglow</b>									
19,4x120 RC	●		●	●		●	●		●
29,5x120_2 RC			●			●			●
<b>Exa</b>									
60x60 RC	●			●			●		
<b>Flow</b>									
19,4x120 RC	●		●	●		●	●		●
29,5x120_2 RC			●			●			●
<b>Formentera</b>									
19,4x120 RC	●		●	●		●	●		●

Acabado normal Natural finish ●  
Antideslizante Anti-slip ●

Formatos vigentes 2021: PORCELANICO Y GRES Current formats 2021: PORCELAIN AND FLOOR	CTE1	CTE2	CTE3	R9	R10	R11	A	B	C
<b>Fossil</b>									
30x60 RC	●				●			●	
60x60 RC	●				●			●	
100x100 RC	●				●			●	
60x60_2 RC			●			●			●
100x100_2 RC			●			●			●
<b>Glamora</b>									
29,5x120 RC	●		●		●	●	●		●
29,5x120_2 RC			●			●			●
<b>Groovy</b>									
47,2x47,2	●			●			●		
<b>Hackney</b>									
47,2x47,2	●			●			●		
<b>Hardblue</b>									
60x60 RC	●				●			●	
60x120 RC	●				●			●	
100x100 RC	●				●			●	
60x60_2 RC			●			●			●
60x120_2 RC			●			●			●
100x100_2 RC			●			●			●
<b>Kalos</b>									
60x60 RC	●				●			●	
<b>Kea</b>									
30,6x59,8 RC	●			●			●		
<b>Kinesis</b>									
31,6x60,8	●			●			●		
<b>Kore</b>									
47,2x47,2	●			●			●		
<b>Legacy</b>									
60x60 RC	●			●			●		
<b>Livermore</b>									
31,6x60,8		●	●		●	●		●	●
47,2x47,2		●			●			●	
60x60 RC		●	●		●	●		●	●
60x120 RC		●			●			●	
75x75 RC		●			●			●	
100x100 RC		●			●			●	
60x60_2 RC			●			●			●
60x120_2 RC			●			●			●
100x100_2 RC			●			●			●
<b>Lume</b>									
60x60 RC		●			●			●	
<b>Make Up</b>									
31,6x60,8	●			●			●		
60x60 RC	●		●	●		●	●		●
60x120 RC	●			●			●		
100x100 RC	●			●			●		
60x120_2 RC			●			●			●
100x100_2 RC			●			●			●

Formatos vigentes 2021: PORCELANICO Y GRES Current formats 2021: PORCELAIN AND FLOOR	CTE1	CTE2	CTE3	R9	R10	R11	A	B	C
<b>Manhattan</b>									
60x60 RC	●			●				●	
<b>Materia</b>									
31,6x60,8	●		●	●		●	●		●
60x60	●			●			●		
75x75 RC	●			●			●		
60x60_2 RC			●			●			●
75x75_2 RC			●			●			●
<b>Metalart</b>									
47,2x47,2	●			●			●		
<b>Mitra</b>									
60x60 RC	●			●			●		
<b>Moon</b>									
30x60 RC	●		●	●		●	●		●
60x60 RC	●		●	●		●	●		●
60x120 RC	●			●			●		
100x100 RC	●			●			●		
60x60_2 RC			●			●			●
100x100_2 RC			●			●			●
<b>Muse</b>									
60x60 RC	●			●			●		
<b>Mustang</b>									
60x60	●		●	●		●	●		●
60x60 RC	●				●			●	
75x75 RC	●				●			●	
60x60_2 RC			●			●			●
61x61_2			●			●			●
75x75_2 RC			●			●			●
<b>Nomade</b>									
60x60 RC		●			●			●	
60x120 RC		●			●			●	
100x100 RC		●			●			●	
60x60_2 RC			●			●			●
60x120_2 RC			●			●			●
100x100_2 RC			●			●			●
<b>Northbay</b>									
31,6x60,8	●			●			●		
60x90 RC	●			●			●		
60x120 RC	●			●			●		
75x75 RC	●			●			●		
100x100 RC	●			●			●		
60x90_2 RC			●			●			●
100x100_2 RC			●			●			●

Acabado normal Natural finish ●  
Antideslizante Anti-slip ●

Formatos vigentes 2021: PORCELANICO Y GRES Current formats 2021: PORCELAIN AND FLOOR	CTE1	CTE2	CTE3	R9	R10	R11	A	B	C
<b>Rotterdam</b>									
22,5x90	●				●		●		
25x150 RC	●			●			●		
20x120 RC	●			●			●		
29,5x120_2 RC			●			●	●		
<b>Salisbury</b>									
31,6x60,8		●	●		●	●		●	●
30x60 RC		●			●			●	
60x60 RC		●			●			●	
60x120 RC		●			●			●	
100x100 RC		●			●			●	
60x60_2 RC			●			●			●
60x90_2 RC			●			●			●
60x120_2 RC			●			●			●
100x100_2 RC			●			●			●
<b>Soho</b>									
22,5x90	●		●	●		●	●		●
<b>Stonehenge</b>									
31,6x60,8		●			●			●	
60x60 RC		●			●			●	
60x90 RC		●			●			●	
60x120 RC		●			●			●	
100x100 RC		●			●			●	
60x60_2 RC			●			●			●
60x90_2 RC			●			●			●
60x120_2 RC			●			●			●
100x100_2 RC			●			●			●
<b>Sunset</b>									
31,6x60,8	●			●			●		
47,2x47,2	●			●			●		
<b>Synergy</b>									
60x60	●			●			●		
60x60_2 RC			●			●			●
<b>Town</b>									
31,6x60,8	●		●		●	●	●		●
31,6x60,8		●		●				●	
<b>Valley</b>									
31,6x60,8		●			●			●	
60x90 RC		●			●			●	
60x60 RC		●			●			●	
60x120 RC		●			●			●	
100x100 RC		●			●			●	
60x60_2 RC			●			●			●
60x90_2 RC			●			●			●
60x120_2 RC			●			●			●
100x100_2 RC			●			●			●

Acabado normal Natural finish ●  
Antideslizante Anti-slip ●

	FORMATO - SIZE	ESPESOR - THICKNESS	CAJAS - BOXES			PALET - PALLET		
			Piezas - Pieces	m²	Kg.*	Cajas - Boxes	m²	Kg.*
<b>GRES PORCELÁNICO</b>								
19,4x120 RC		10,1mm	7	1,629	39,466	30	48,870	1184
20x120 RC		10,1mm	7	1,680	42,667	30	50,400	1280
22,5x90		8,5mm	6	1,215	22,416	60	72,900	1345
25x150		10,5mm	6	1,080	23,500	40	43,200	940
29,5x120 RC		10,1mm	4	1,416	33,906	32	45,312	1085
30x60 RC		9,5mm	6	1,080	22,250	40	43,200	940
30,6x59,8 RC		8,5mm	6	1,098	21,000	40	43,920	840
31,6x60,8		8,5mm	6	1,150	21,750	40	46,000	870
47,2x47,2		8,5mm	6	1,340	26,428	56	75,040	1480
60x60		9,5mm	3	1,080	23,050	40	43,200	922
60x60 RC		9,5mm	3	1,080	23,050	40	43,200	922
60x90 RC		10mm	3	1,620	37,750	32	51,84	1208
60x120 RC		10,1mm	2	1,440	34,333	30	43,200	1030
60x120 RC LAP		10,1mm	2	1,440	35,333	30	43,200	1060
60x120 RCP		10,5mm	2	1,440	33,125	32	46,080	1060
75x75 RC		11mm	2	1,125	26,666	45	50,625	1200
75x150 RCP		10,1mm	1	1,130	28,000	40	45,200	1120
100x100 RC		11,5mm	2	2,000	54,166	24	48,000	1300
100x100 RC LAP		11,5mm	2	2,000	54,166	24	48,000	1300
120x120 RCP		10,7mm	1	1,440	37,220	36	51,840	1340
<b>DECORADOS</b>								
29,5x29,5		10,1mm	10	0,870	-	-	-	-
30x30		10,1mm	10	1,000	-	-	-	-
<b>REVESTIMIENTO</b>								
20x60		9mm	9	1,080	18,440	64	69,120	1160
25x75		8,7mm	7	1,310	20,833	48	62,880	1000
33x100_0,6		6mm	6	2,000	24,000	48	96,000	1152,00
33x100		10,8mm	4	1,330	25,000	48	63,940	1200
<b>OUTDOOR 20mm.</b>								
20x20 RC		20mm	12	0,480	22,543	57	27,360	1285
29,5x120 RC		20mm	2	0,708	34,843	32	22,656	1115
60x60 RC		20mm	2	0,720	33,833	30	21,600	1015
60x90 RC		20mm	2	1,080	49,416	24	25,920	1186
60x120 RC		20mm	1	0,720	34,370	27	19,440	928
61x61		20mm	2	0,744	34,266	30	22,320	1028
75x75 RC		20mm	1	0,562	27,555	45	25,290	1240
100x100 RC		20mm	1	1,000	49,000	24	24,000	1180
<b>VIKER 7mm.</b>								
40x120 RC		7mm	4	1,920	29,791	24	46,080	715
40x120 RC REL		7mm	5	2,400	37,777	18	43,200	680

\*Valores aproximados  
Approximated values





## 1. TAREAS PREVIAS A LA OBRA

### LIMPIEZA DE LA SUPERFICIE

Ya sea porque queremos cambiar el material cerámico existente o porque queremos ponerlo nuevo en un lugar donde nunca lo ha habido, es necesario realizar algunos trabajos de preparación previos a la propia obra.

Una de las tareas más importantes es garantizar que la superficie en la que se colocará el nuevo material cerámico sea totalmente apta para trabajar. Para conseguir este objetivo, debemos llevar a cabo algunos trabajos de preparación para garantizar que esté totalmente limpia de polvo o cualquier otro tipo de elemento o artefacto. De esta forma, nos aseguraremos de que el material de agarre se adhiera de forma acertada a la superficie.

Las tareas de limpieza engloban los siguientes cometidos:

- En el caso de que ya exista algún tipo de material cerámico instalado previamente, deberemos, de forma preliminar, romper las impurezas hasta soltarlas completamente utilizando un martillo y un cincel.
- Eliminar con las herramientas o detergentes adecuados las imperfecciones que detectemos en la superficie en la que se colocará posteriormente el material cerámico.
- Comprobar que la superficie a trabajar quede completamente lisa, sin deformaciones ni desniveles.

## COMPROBACIÓN DE LAS PIEZAS

### Comprobación del marcado de las cajas.

Se debe comprobar que el marcado de los diferentes lotes (palés) posea una identificación homogénea y acorde con lo que se ha pedido, verificando que no haya cajas marcadas de forma diferente.

### Comprobación del aspecto del producto.

Se debe verificar que las características de color, brillo, diseño, textura, relieve, etc. se correspondan con el material solicitado.

### Comprobación de la homogeneidad del tono.

Hay que comprobar que todas las cajas lleven el mismo código de tono.

### Análisis de defectos superficiales.

Se tomará como muestra la totalidad de las piezas cerámicas de las cajas seleccionadas y, sobre cada una de ellas, se determinará la ausencia o presencia de defectos visibles que no puedan considerarse como "efectos decorativos".

### Resistencia química.

El objeto de esta verificación es asegurarnos de que la limpieza con un producto químico determinado no produzca un deterioro irreversible de la superficie de la baldosa cerámica, como una pérdida de brillo o decoloración.

Sobre una de las piezas, depositaremos una cantidad significativa de producto de limpieza o desincrustación que cubra una superficie significativa, y dejaremos la pieza en estas condiciones durante 24 horas. Posteriormente, lavaremos con agua abundante la superficie en la que se ha empleado el producto y comprobaremos que no presenta ninguna alteración.



## 1. PRELIMINARY TASKS

### CLEANING THE SURFACE

Whether we are going to replace existing tiles or it is a completely new installation, there are a few things to be done before starting work.

One of the most important tasks is preparing the surface to be tiled. This involves several preparatory processes that will guarantee the absence of dust or any other impurity or artefact. This will improve adhesion to the substrate.

Preparation includes the following tasks:

- A previously tiled surface must be completely stripped of all ceramic material using a hammer and chisel.
- Remove any imperfections from the surface to be tiled with the help of suitable tools or detergents.
- Make sure that the surface is completely flat, without any irregularities.

## CHECK THE MATERIALS

Check the markings on the boxes.

The products from distinct pallets must be marked with a common identification, matching that ordered.

Check product appearance.

It must be confirmed that the product characteristics, such as colour, finish, design, texture etc. agree with what was ordered.

Check the shade.

All product packaging should carry matching shade codes.

Check for surface defects.

All tiles from selected boxes should be examined for visible defects that cannot be considered "decorative effects".

Chemical endurance.

The object of this test is to determine whether cleaning the tile with a chemical product has any irreversible effect on the surface of the tile, such as dulling or discolouration.

We take one tile and apply a cleaning or descaling product to a significant area of the face. It is then left for 24 hours. Then the surface is washed with plenty of water and checked for any signs of change.



## 1. TÂCHES À RÉALISER AVANT LES TRAVAUX

### NETTOYAGE DE LA SURFACE

Que ce soit pour remplacer un matériau céramique existant ou pour en poser là où il n'y en avait pas, quelques tâches de préparation sont nécessaires avant de commencer les travaux à proprement parler.

L'une des opérations les plus importantes est de préparer la surface qui accueillera le nouveau matériau céramique pour pouvoir travailler convenablement. Dans ce but, il faut réaliser quelques travaux de préparation pour faire en sorte qu'elle soit complètement propre et exempte de poussière, de tout autre élément ou d'appareils. Nous aurons ainsi la certitude que le matériau de liaison adhère correctement à la surface.

Les opérations de nettoyage comprennent les tâches suivantes:

- Lorsqu'il existe un matériau céramique quelconque déjà installé, il faut tout d'abord briser les impuretés en les détachant complètement à l'aide d'un marteau ou d'un burin.
- À l'aide des outils ou des produits détergents adaptés, éliminer les imperfections détectées sur la surface destinée à accueillir le matériau céramique.
- Veiller à ce que la surface de travail soit entièrement lisse, sans déformations ou dénivelés.

## VÉRIFICATION DES CARREAUX

Vérification du marquage des boîtes.

S'assurer que le marquage des différents lots (palettes) comporte une identification homogène et correspondant à la commande, et qu'il n'y a pas de boîtes marquées différemment.

Vérification de l'aspect du produit.

Vérifier que les caractéristiques (couleur, brillance, dessin, texture, relief, etc.) correspondent bien à celles du matériau commandé.

Vérification de l'homogénéité du coloris.

S'assurer que toutes les boîtes ont le même code de coloris.

Analyse des défauts superficiels.

Prendre comme échantillon la totalité des carreaux de céramique des boîtes sélectionnées et, pour chacun d'eux, déterminer l'absence ou la présence de défauts visibles qui ne peuvent pas être considérés comme des « effets décoratifs ».

Résistance chimique.

Cette vérification a pour but de s'assurer que le nettoyage réalisé avec un produit chimique en particulier n'entraîne pas une détérioration irréversible de la surface du carreau de céramique, par exemple une perte de brillance ou une décoloration.

Déposer une bonne quantité de produit de nettoyage ou désincrustant de manière à couvrir une surface significative de l'un des carreaux, puis laisser reposer dans ces conditions pendant 24 heures. Laver ensuite abondamment à l'eau la surface couverte de produit et s'assurer qu'elle ne présente aucune altération.



## 1. VOR DER VERLEGUNG

### REINIGUNG DER OBERFLÄCHE

Egal, ob wir das vorhandene Keramikmaterial wechseln wollen oder es neu verlegen wollen, sind einige Vorbereitungsvorgänge notwendig.

Eine der wichtigsten Aufgaben ist es, zu garantieren, dass die Oberfläche, auf die das neue Keramikmaterial verlegt wird, geeignet ist. Hierfür müssen wir einige Vorbereitungsvorgänge vornehmen, um zu garantieren, dass sie vollständig frei von Staub oder sonstigen Elementen oder Artefakten ist. So vergewissern wir uns, dass das Material korrekt auf der Oberfläche haftet.

Die Reinigungsvorgänge beinhalten Folgendes:

- Falls schon ein Keramikmaterial verlegt ist, müssen wir vorerst die Unreinheiten mit einem Hammer und einem Meißel vollständig entfernen.
- Man muss die Unreinheiten mit geeigneten Werkzeugen oder Reinigungsmitteln entfernen, bevor das neue Keramikmaterial verlegt wird.
- Es muss vergewissert werden, dass die Oberfläche vollkommen glatt ist und sie keine Deformationen oder Unebenheiten vorweist.

## ÜBERPRÜFUNG DER STÜCKE

Überprüfung der Markierungen der Kisten.

Es muss überprüft werden, dass die verschiedenen Posten (Paletten) korrekt mit einer homogenen Identifizierung markiert wurden, die der Bestellung entspricht. Es muss sichergestellt werden, dass keine Kisten anders markiert sind.

Überprüfung des Aussehens des Produktes.

Es muss überprüft werden, dass die Farbe, der Glanz, das Design, die Textur, die Oberfläche, usw. mit dem bestellten Material übereinstimmen.

Überprüfung der Einheitlichkeit des Farbtons.

Es muss überprüft werden, dass alle Kisten den gleichen Code für den Farbton haben.

Überprüfung zu Oberflächendefekte.

Es wird ein Muster des Farbtons der Stücke aus den ausgewählten Kisten entnommen und es wird sichergestellt, dass keine sichtbaren Defekte vorhanden sind, die nicht als „dekorative Effekte“ verstanden werden können.

Chemische Widerstandskraft.

Das Ziel dieser Überprüfung ist es, die Reinigung mit einem bestimmten chemischen Produkt keine irreversiblen Schäden auf der Oberfläche der Keramikfliesen entstehen, wie etwa ein Glanz- oder Farbverlust.

Auf ein Stück wird eine bestimmte Menge Reinigungsmittel oder Kalkreiniger gegeben und auf der Oberfläche verteilt. Das Stück wird 24 Stunden in diesem Zustand gelassen.

Danach wird die Oberfläche mit viel Wasser abgespült und es wird überprüft, dass keine Veränderung aufgetreten ist.



## 2. TIPO DE COLOCACIÓN

### En seco

Según el material que se va instalar y su espesor, en este caso los modelos de la familia OUTDOOR20 se pueden colocar en seco, sin necesidad de mortero ni adhesivos, sobre los siguientes elementos:

- Plots
- Césped
- Gravilla
- Arena

Las ventajas del tipo de colocación son las siguientes:

- No requiere colas.
- Colocación rápida, ecológica y de alto nivel estético.
- Inmediatamente transitable y fácilmente removible.

### Tradicional

Este tipo de colocación es una técnica adhesiva para pavimentación con tránsito de vehículos, lugares comerciales e industriales, rampas de acceso a garajes, etc.

Las ventajas de este tipo de colocación son las siguientes:

- Soporta las tensiones de alto tránsito.
- No absorbe manchas; se limpia fácilmente, incluso con una manguera a presión.

### Fachadas

El porcelánico es un material idóneo para instalar en fachadas debido a su baja absorción de agua. Estos son los tipos de sistema de fachadas con los que se puede instalar:

- Grapa vista.
- Grapa oculta.
- Anclaje encapsulado.
- Anclaje químico.

Las ventajas de este tipo de colocación son las siguientes:

- Aislamiento acústico.
- Aislamiento energético.
- Impermeabilidad.



## 2. TYPE OF FIXING

### DRY

Depending on the material to be installed and its thickness, in this case models from the OUTDOOR20 family, they can be installed dry, without any need for cement or adhesive, on the following substrates:

- Raised floors.
- Grass.
- Gravel.
- Sand.

The advantages of this type of fixing are:

- No adhesive required.
- Rapid fixture, ecological and aesthetically pleasing.
- Immediately traversable and easily lifted.

### Traditional

For this type of installation special ceramic cements are used which leave the tiles permanently fixed and immovable.

The advantages of this type of fixing are:

- Highly traversable (pedestrians).
- Can be grouted.

### Façades

Porcelain is the ideal material for façades due to its low water absorption. Following are the types of suitable systems for tiling façades:

- Exposed clips.
- Concealed clips.
- Encapsulated anchor.
- Chemical anchor.

The advantages of this type of fixing are:

- Acoustic insulation.
- Thermal insulation.
- Impermeability.

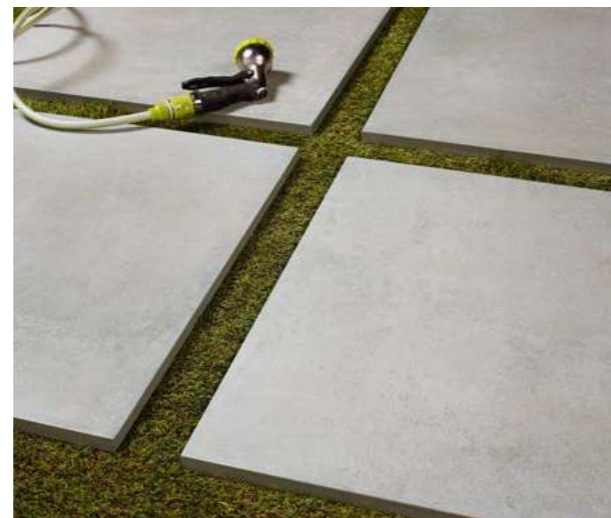

## 2. TYPE DE POSE

### À SEC

En fonction du matériau à poser et de son épaisseur, dans ce cas les modèles de la famille OUTDOOR20, on peut faire une pose à sec sur les éléments suivants, sans avoir à utiliser de mortiers ou de colles:

- Plots.
- Pelouse.
- Gravier.
- Sable.

Voici les avantages de ce type de pose :

- Aucune colle n'est nécessaire.
- Pose rapide, écologique et très esthétique.
- Immédiatement accessible et facile à enlever.

### Traditionnelle

Pour ce type de pose, on utilise du ciment conçu spécialement pour la céramique. Une fois posés, les carreaux sont entièrement fixés et il n'est pas possible de les déplacer.

Voici les avantages de ce type de pose :

- Supporte un passage intensif (piétons).
- Permet le jointoiement du revêtement de sol ou de mur.

### Façades

Grâce à une faible absorption d'eau, le grès cérame est un matériau idéal pour les façades. Les systèmes d'installation des façades sont les suivants :

- Agrafe apparente.
- Agrafe invisible.
- Ancrage encapsulé.
- Ancrage chimique.

Voici les avantages de ce type de pose :

- Isolation acoustique.
- Isolation thermique.
- Imperméabilité.



## 2. VERLEGUNGSTYP

### TROCKEN

Je nach dem Material und seiner Dicke, in diesem Fall die Modelle der Familie OUTDOOR20, können diese ohne Mörtel oder Kleber auf folgenden Elementen trocken verlegt werden:

- Plots.
- Gras.
- Kies.
- Sand.

Die Vorteile dieser Verlegung sind:

- Sie bedarf keinen Kleber.
- Schnelle, ökologische und ästhetisch schöne Verlegung.
- Kann sofort begangen und einfach wieder entfernt werden.

### Traditionell

Mit dieser Verlegung werden spezielle Kleber für Keramik benutzt, wobei das Material vollkommen befestigt wird und die Stücke nicht mehr bewegt werden können.

Die Vorteile dieser Verlegung sind:

- Sie hält gut einer häufigen Begehung stand (durch Personen).
- Der Belag oder die Verkleidung können verfugt werden.

### Fassaden

Das Feinsteinzeug ist ein ideales Material, um es an Fassaden zu verlegen, da es wenig Wasser aufnimmt. Diese sind die Fassadensysteme, auf die es verlegt werden kann:

- Sichtbare Klammern.
- Unsichtbare Klammern.
- Verdeckte Verankerung.
- Chemische Verankerung.

Die Vorteile dieser Verlegung sind:

- Schalldämmung.
- Energetische Dämmung.
- Wasserundurchlässigkeit.
- Isolation thermique.
- Imperméabilité.





### 3. COLOCACIÓN

#### ELECCIÓN DE HERRAMIENTAS

Resulta de gran importancia la correcta elección de las herramientas y útiles que nos ayudarán a llevar a cabo la colocación de nuestro material.

• Aplicador de mortero	• Marcador, soporte y plantilla
• Caja de herramientas	• Maza y aplanador
• Cortafíos y cincel	• Nivel
• Crucetas, "T" y cuñas	• Paleta
• Escuadra	• Plomada
• Espátula	• Rascador
• Flexómetro	• Maceta y martillo
• Llana, peine y talocha	• Tenazas
• Mesa de trabajo	• Ventosa

#### DISPOSICIÓN DE LAS PIEZAS

Antes de empezar a colocar cualquier pieza, hay que decidir la orientación y disposición del modelo a instalar. Presentamos algunos de los ejemplos más comunes:

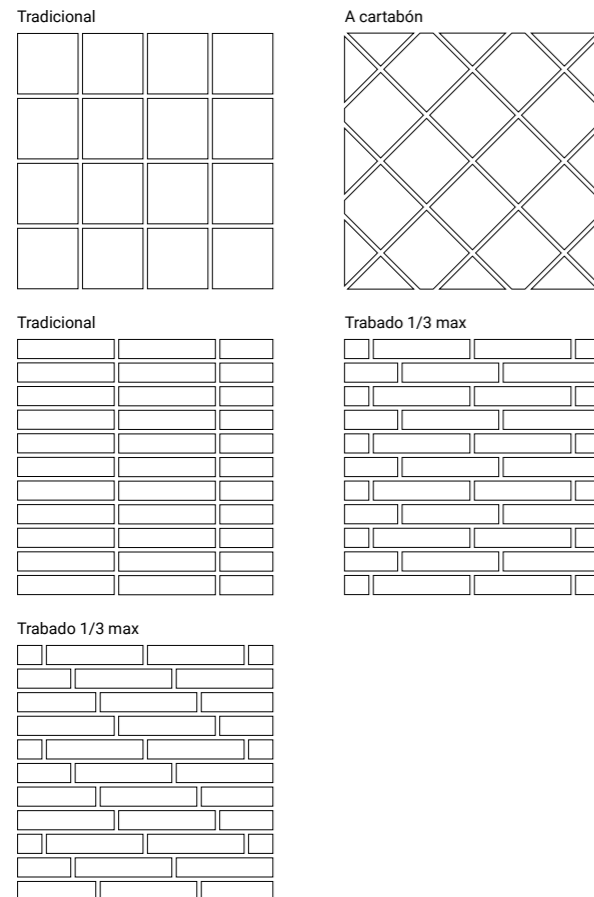

### 3. FIXING

#### CHOOSING TOOLS

Selecting the correct tools with which we are to work is of great importance.

• Trowel	• Marker, support and template
• Toolbox	• Mallet and float
• Cold chisel	• Spirit level
• Spacers and wedges	• Grouting trowel
• Set square	• Plumb line
• Spatula	• Scraper
• Measuring tape	• Mace and hammer
• Toothed trowel, comb and leveller	• Pincers
• Workbench	• Suction cup

#### TYPE OF INSTALLATION

Before starting to fix the tiles, the orientation and layout must be decided. Here we list the more common styles:

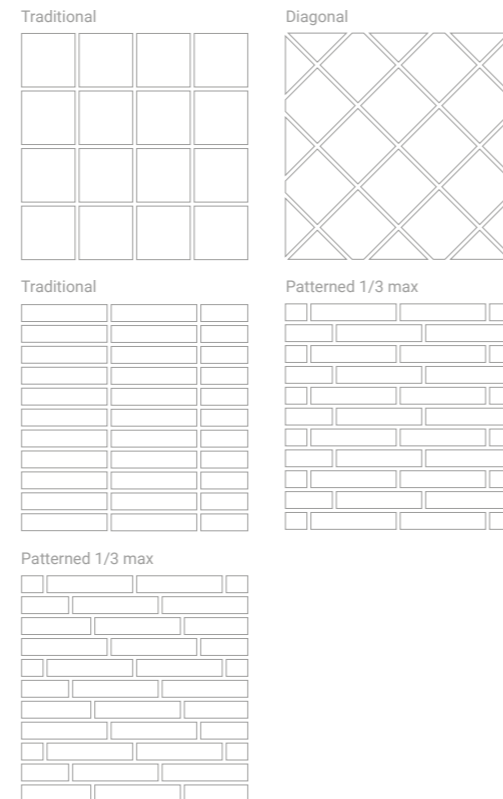

### 3. POSE

#### CHOIX DE L'OUTILLAGE

Il est extrêmement important de bien choisir le matériel et l'outillage nécessaires à la pose du matériau.

• Applicateur de mortier	• Marqueur, support et gabarit
• Boîte à outils	• Maillet et batte de carreleur
• Ciseaux à froid et burin	• Niveau
• Croisillons, profilés en T et cales	• Truelle
• Équerre	• Fil à plomb
• Spatule	• Racleur
• Mètre ruban	• Massette et marteau
• Taloche crantée, peigne et taloche	• Tenailles
• Table de travail	• Ventouse

#### DISPOSITION DES CARREAUX

Avant de commencer à poser les carreaux, il faut avant tout opter pour une orientation et une disposition du modèle à poser. Voici les exemples les plus courants:

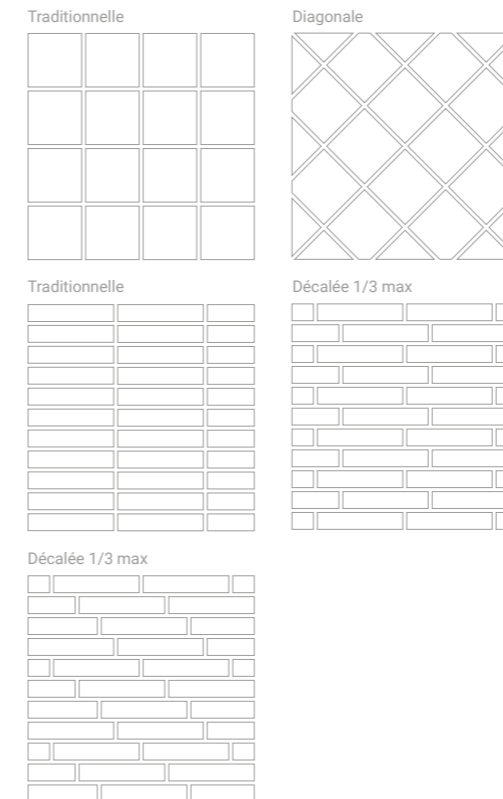

### 3. VERLEGUNG

#### AUSWAHL DER WERKZEUGE

Es ist besonders wichtig, die richtigen Werkzeuge und Hilfsmittel auszusuchen, um das Material zu verlegen.

• Mörtelanwender	• Stift, Unterlage und Schablone
• Werkzeugkoffer	• Stößel und Planierer
• Beizeisen und Meißel	• Wasserwaage
• Kreuzköpfe, „T“ und Keile	• Kelle
• Reißschmiege	• Senkblei
• Spachtel	• Schaber
• Rollmaßband	• Fäustel und Hammer
• Gezahnte Kelle, Kelle und Reibebrett	• Zangen
• Arbeitsbank	• Saugnapf

#### ANORDNUNG DER STÜCKE

Bevor die Stücke verlegt werden, muss die Orientierung und die Anordnung des Modells ausgesucht werden. Wir stellen die häufigsten Beispiele vor:

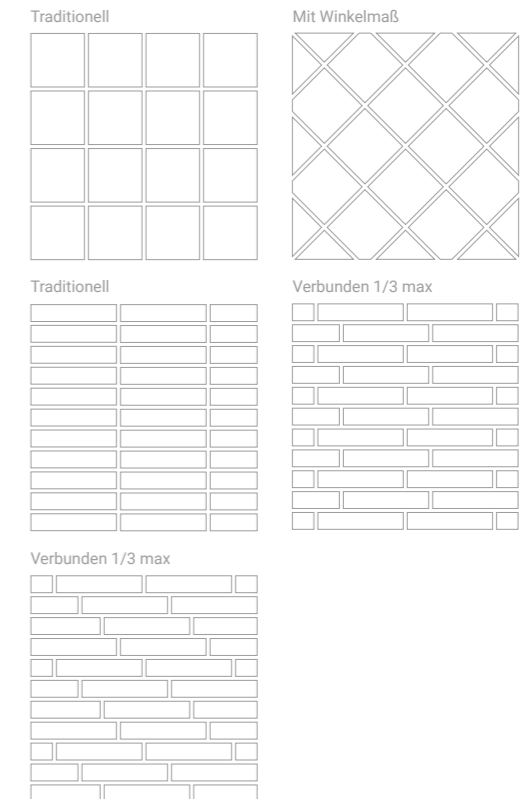



## 4. REJUNTADO

### SELECCIONAR COLOR DE REJUNTADO

A criterio de cada cliente, deberá seleccionar una pasta de rejuntado apta para cerámica del color que prefiera.

Nosotros recomendamos que sea de un tono similar al de la pieza de cerámica.

### APLICACIÓN

Siempre después de que el material esté instalado y seco, introducir entre las piezas de cerámica la cantidad necesaria para llenar la junta con una paleta de goma. Rápidamente con una esponja bien humedecida, retirar el sobrante. Repetir el proceso hasta cubrir todas las juntas de la pared o del pavimento.

## 5. LIMPIEZA POSTERIOR A LA OBRA

Antes de limpiar nuestro material cerámico, será necesario que apartemos todos aquellos elementos que entorpezcan la limpieza para poder llegar a todos los rincones y eliminar por completo la suciedad. De este modo, deberemos apartar escaleras, herramientas y demás obstáculos que puedan dificultar esta tarea.

A continuación barreremos o aspiraremos el suelo de cerámica para retirar así el polvo y demás restos sólidos que pueda haber, como tornillos, grapas, crucetas, etc. Deberemos hacer hincapié en las esquinas o rincones de las estancias, ya que es donde suele acumularse este tipo de suciedad.

Seguidamente, ya se podrá empezar a fregar el piso cerámico y, para ello, se puede optar entre algún producto comercial específico para suelos de cerámica. De este modo, se deberá mezclar el limpiador comercial (siguiendo las instrucciones del envase) en el cubo de agua y limpiar toda la superficie cerámica con la fregona.

En los casos que haya pegotes de cemento o de material de rejuntado, podremos deshacernos de ellos con un estropajo suave (haremos una prueba primero sobre un trozo de pieza en la que, en el caso de que se pudiese rayar, no se vea la imperfección para asegurarnos de que podemos usar el estropajo seleccionado).

## 6. MANTENIMIENTO

Muchos productos de limpieza de uso general que están disponibles son aceptables para el uso en nuestros productos. Se pueden emplear para la limpieza diaria detergentes o desengrasantes diluidos en agua caliente, según las indicaciones del envase del limpiador.

Es importante que el limpiador no tenga base de aceite, grasa animal o jabón. Estos componentes pueden dejar un residuo invisible al atrapar la suciedad (estratificaciones de cal de detergente o residuos de suciedad). También es importante que la baldosa reciba un enjuague a fondo con agua limpia después de que el proceso de limpieza se haya completado.

\*\*Es muy importante tener en cuenta que el ácido fluorhídrico (HF) y derivados pueden dañar irremediabilmente la baldosa.

Los pasos generales de limpieza regular para nuestros productos cerámicos se pueden resumir del siguiente modo:

• Retirar cualquier residuo sólido o líquido de la baldosa, barriendo con una escoba de cerdas suaves o pasando la aspiradora.

• Limpiar los derrames líquidos tan pronto como sea posible.

• Aplicar la cantidad y dilución del limpiador recomendadas para la baldosa (ver indicaciones del fabricante del limpiador).

Durante su uso, la limpieza de la baldosa debe hacerse de forma similar a la limpieza de cristales. Se pueden emplear productos de tipo amoniacal e incluso lejía, ambos diluidos.



## 4. GROUTING

### SELECTING GROUT COLOUR

A grout suitable for ceramics must be sourced in the client's chosen colour. We recommend a shade similar to that of the tile.

### APPLICATION

When the tiles are installed and the cement has dried, fill the joint with paste using a rubber grouting trowel. Quickly remove any surplus with a wet sponge. Repeat the process until all joints are filled.

## 5. FINAL CLEAN UP

Before we start cleaning, the site must be cleared of anything that could hinder access to any part. We need to be able to reach into every corner in order to clean completely. This means removing ladders, tools or any obstacle that could get in the way.

Then we sweep or vacuum the tiled floor to remove any dust or other foreign objects that there might be, such as screws, clips or spacers. Special attention must be paid to corners of the area, as this is where this type of residue tends to gather.

Now the cleaning can begin. Any preferred commercial product may be chosen if it is specifically designed for tiled floors. The commercial product must be mixed with water according to the product label. Then it is used to clean the whole area with a mop.

If we find traces of cement or grout, we can remove them using a smooth scourer. Firstly we test the scourer on a piece of tile to be certain that it does not leave scratches.

## 6. MAINTENANCE

Many commercially available cleaning products are suitable for use with our products. Day to day cleaning can be done with detergents or degreasers diluted in hot water, following the instructions on the product label.

Products based on oil, animal fat or soap must not be used. These substances can leave an invisible residue when cleaning, such as layers of detergent or dirt. When the cleaning is complete, the tiling must be copiously rinsed with clean water.

\*\*It is vitally important to remember that hydrofluoric acid or derivatives thereof can do irreparable damage to the tiling.

Following are the recommended steps for the regular cleaning of our products:

• Remove any solid or liquid residue from the surface using a soft broom or a vacuum cleaner.

• Clean off any liquid spillages as soon as possible.

• Dilute and apply the product according to the instructions.

Tiling should be cleaned similarly to glass surfaces. Ammonium based products and bleach can be used if diluted.



## 4. JOINTOIEMENT

### CHOISIR LA COULEUR DES JOINTS

Selon leurs goûts, les clients peuvent choisir la couleur souhaitée pour l'enduit de jointoiment spécial céramique.

Nous conseillons un ton semblable à celui du carreau de céramique.

### APPLICATION

Une fois le matériau posé et sec, introduire la quantité nécessaire entre les carreaux de céramique et remplir le joint avec une truelle en caoutchouc. À l'aide d'une éponge bien humide, retirer rapidement le surplus. Répéter l'opération de façon à couvrir la totalité des joints du mur ou du sol.

## 5. NETTOYAGE FIN DE CHANTIER

Avant de nettoyer le matériau céramique, il faut déplacer tous les éléments susceptibles de gêner le nettoyage pour pouvoir atteindre tous les recoins et éliminer entièrement la saleté. C'est pourquoi il faut ôter les échelles, les outils et tout autre obstacle qui pourrait entraver cette tâche.

Passer ensuite le balai ou l'aspirateur sur le sol en céramique pour éliminer la poussière et les autres restes solides tels que vis, agrafes, croissillons, etc. Bien insister dans les coins et les angles des pièces, c'est-à-dire là où ce type de saleté a généralement tendance à s'accumuler.

On peut ensuite commencer à passer la serpillière sur le sol, en choisissant pour cela dans le commerce un produit spécialement conçu pour les sols en céramique. Bien mélanger le produit de nettoyage dans un seau d'eau (en respectant les instructions de l'emballage), et nettoyer toute la surface en céramique à l'aide d'une serpillière.

Lorsqu'il reste des traces de ciment ou de matériau de jointoiment, on peut les éliminer en utilisant un tampon doux (pour savoir si le tampon sélectionné convient, commencer par faire un test sur un morceau de céramique peu visible, de manière à ne pas voir l'imperfection en cas de rayure).

## 6. ENTRETIEN

Parmi les produits d'entretien général disponibles, nombreux sont ceux qui peuvent être utilisés sur nos produits. Pour le nettoyage quotidien, on peut utiliser des détergents ou des dégraissants dilués dans l'eau chaude, selon les indications de l'emballage du nettoyant.

Il est important de choisir un nettoyant qui n'est pas à base d'huile, de graisse animale ou de savon. Ces composants peuvent laisser un résidu invisible lorsqu'ils retiennent la saleté (stratifications de calcaire de détergent ou résidus de saleté). Il est important de bien rincer le carreau à l'eau propre après avoir terminé le processus de nettoyage.

\*\*Il est important de savoir que l'acide fluorhydrique (HF) et ses dérivés peuvent abîmer le carreau de façon irréversible.

On peut résumer de la façon suivante les étapes générales de nettoyage ordinaire de nos produits en céramique:

• Retirer tout résidu solide ou liquide du carreau à l'aide d'un balai à poils souples ou d'un aspirateur.

• Nettoyer les liquides déversés aussitôt que possible.

• Respecter la quantité et la dilution du nettoyant recommandées pour le carreau (voir indications du fabricant du produit).

Pendant l'usage, effectuer le nettoyage du carreau de la même manière que le nettoyage des vitres. On peut utiliser des produits à base d'ammoniaque et même de l'eau de Javel, tous deux dilués.



## 4. VERFUGUNG

### VERFUGUNGSFARBE AUSSUCHEN

Der Kunde kann die Verfugungspaste für Keramik in der gewünschten Farbe auswählen. Wir empfehlen, dass diese Farbe dem Keramikstück ähnelt.

### ANWENDUNG

Nachdem das Material verlegt und trocken ist, kann mit einer Gummispachtel die geeignete Menge Paste zwischen die Keramikstücke gepresst werden. Danach müssen die Reste sofort mit einem feuchten Schwamm entfernt werden. Der Vorgang wird wiederholt, bis alle Fugen an der Wand oder dem Belag geschlossen sind.

## 5. REINIGUNG NACH DER VERLEGUNG

Bevor das Keramikmaterial gereinigt wird, ist es notwendig, dass wir alle Elemente, welche die Reinigung stören könnten, zu entfernen, um in alle Ecken reichen zu können, um den Schmutz vollständig entfernen zu können. So müssen also Leitern, Werkzeuge und sonstige Hindernisse entfernt werden, die die Aufgabe behindern. Danach kehren oder saugt man den Keramikboden und entfernt den Staub und andere feste Reste wie Schrauben, Klammern, Profile, usw. Es muss besonders auf die Ecken der Räume geachtet werden, da sich dort mehr Schmutz ansammelt.

Darauf kann der Keramikboden mit einem Mopp gereinigt werden, wobei ein spezifisches Produkt für Keramik ausgesucht werden kann. So wird das gewählte Reinigungsprodukt (laut den Angaben auf der Verpackung) in einem Eimer Wasser verdünnt und die gesamt Oberfläche mit dem Mopp gereinigt.

Wenn Zementreste oder Reste des Verfugungsmaterials vorhanden sind, kann man diese mit einem weichen Schwamm entfernen (zuerst an eine wenig sichtbaren Stelle probieren, ob das Stück verkratzt. So wird sichergestellt, dass der Schwamm benutzt werden kann).

## 6. REINIGUNG

Viele verfügbare, handelsübliche Reinigungsprodukte können auf unseren Produkten benutzt werden. Für die tägliche Reinigung können Reinigungsmittel oder Fettlösmittel in warmem Wasser verdünnt werden, immer nach den Angaben auf der Verpackung.

Es ist wichtig, dass das Reinigungsmittel keine Ölbasis, Tierfettbasis oder Seifenbasis hat. Diese Mittel können unsichtbare Rückstände hinterlassen, die Schmutz aufnehmen können (Kalkrückstände der Reinigungsmittel oder Schmutz). Es ist auch wichtig, dass die Fliese nach dem Reinigungsvorgang gründlich mit Wasser abgewischt wird.

\*\*Es ist sehr wichtig, dass Flusssäure (HF) und Derivate die Fliese unabwendbar beschädigen können.

Die allgemeinen Schritte für eine regelmäßige Reinigung unserer Keramikprodukte können wie folgt zusammengefasst werden:

• Jegliche feste oder flüssige Rückstände von der Fliese entfernen, indem mit einem weichen Besen gekehrt oder mit einem Staubsauger gereinigt wird.

• Flüssige Reste so bald wie möglich entfernen.

• Die Menge und Lösung des für Keramikfliesen empfohlenen Reinigungsmittels anwenden (sehen Sie die Herstellerangaben).

Während der Nutzung muss die Reinigung wie die Reinigung von Glas vorgenommen. Sie können Ammoniak oder Lauge benutzen, beides verdünnt.



## 1. SUELOS ANTIDESLIZANTES

La seguridad en la utilización de los pavimentos es una de las prioridades de ROCERSA. Actualmente existen en el ámbito internacional varios sistemas para evaluar la resbaladidad de los materiales. Los ensayos que ROCERSA aplica a sus pavimentos son los siguientes:

### RAMPA

El método de rampa inclinada, de amplia difusión en toda Europa, consiste en una plataforma regulable en inclinación sobre la que camina un técnico cualificado calzado con suela normalizada o pie descalzo. Esta rampa, que se encuentra lubricada con aceite o agua jabonosa respectivamente, incrementa progresivamente el ángulo respecto a la horizontal hasta que el técnico detecta indicios de deslizamiento. En el caso de calzado y aceite como lubricante, los pavimentos se clasifican en cinco categorías: de R9 a R13, donde el número mayor indica una fricción estática también mayor.

Clasificación	Ángulo de inclinación	Adecuado para zonas con:
R9	3° - 10°	
R10	10° - 19°	Fricción estática NORMAL
R11	19° - 27°	Fricción estática AUTOMÁTICA
R12	27° - 35°	Fricción estática ALTA
R13		FRICCIÓN ESTÁTICA MUY ALTA

### PÉNDULO

El método del péndulo de fricción, prescrito por el Código Técnico de la Edificación, consiste en un péndulo de medidas normalizadas que soporta un deslizador de caucho. La altura del equipo se ajusta para conseguir que el deslizador, que soporta una carga constante, mantenga el contacto con la superficie durante una distancia conocida. Midiendo la diferencia entre la altura inicial y la alcanzada por el péndulo después de la fricción, se asigna un valor a la superficie ensayada. Los suelos analizados con este sistema se clasifican en 4 categorías, de la 0 a la 3, donde un número mayor indica una mayor resistencia al deslizamiento.

Clasificación	Ángulo de inclinación	Adecuado para zonas con:
CTE 0	Rd ≤ 15	
CTE 1	15 > Rd ≤ 35	• Interiores con pendientes < 6%
CTE 2	35 Rd ≤ 45	• Interiores con pendientes P 6% y escaleras • Interiores húmedos (duchas, aseos, cocinas, etc.) con pendientes < 6%
CTE 3	Rd > 45	• Interiores húmedos (duchas, aseos, cocinas, etc.) con pendientes P 6% • Interiores húmedos con grasas, aceites, etc. • Exteriores y piscinas



## 1. ANTI-SLIP FLOORING

Safe usage of flooring is one of ROCERSA's priorities. There are various internationally recognised systems for evaluating a material's slip resistance. The tests that ROCERSA carries out on its products are the following:

### RAMPE

The variable angle ramp method, in use all over Europe, consists of a variable angle platform on which a qualified technician walks up and down either wearing safety boots or barefoot. This ramp, which is lubricated with either oil or soapy water, is gradually inclined until the technician starts to slip. For an oil lubricated ramp and operator wearing boots, flooring is classified in five categories; R9 to R13, where a higher number indicates greater static friction.

Classification	Angle of inclination	Suitable for areas with:
R9	3° - 10°	
R10	10° - 19°	NORMAL static friction.
R11	19° - 27°	AUTOMATIC static friction.
R12	27° - 35°	HIGH static friction
R13		VERY HIGH STATIC FRICTION

### PENDULUM

The pendulum slip resistance test, required by the Spanish technical building code, consists of a standardised pendulum supporting a rubber slider. Height is adjusted so that the slider, with a constant load, remains in contact with the surface for a set distance. According to the difference between the starting height and that reached by the pendulum after the friction, the flooring is graded with a value. Surfaces analysed with this method are classified as 0 to 3, where a higher number means greater slip resistance.

Classification	Angle of inclination	Suitable for areas with:
CTE 0	Rd ≤ 15	
CTE 1	15 > Rd ≤ 35	• Interiors with incline < 6%
CTE 2	35 Rd ≤ 45	• Interiors with incline P 6% and stairs • Interiors with moisture (showers, bathrooms, kitchens etc.) with incline < 6%
CTE 3	Rd > 45	• Interiors with moisture (showers, bathrooms, kitchens etc.) with incline P 6% • Interiors with grease or oil etc. • Exteriors and pools



## 1. SOLS ANTIDÉRAPANTS

La sécurité d'utilisation des revêtements de sol est l'une des priorités de ROCERSA. À l'heure actuelle, il existe plusieurs systèmes au niveau international pour évaluer la glissance des matériaux. Voici les tests réalisés par ROCERSA sur ses revêtements de sol :

### RAMPE

La méthode de la rampe inclinée, très courante dans toute l'Europe, est réalisée sur une plateforme à inclinaison réglable sur laquelle marche un technicien qualifié, avec des chaussures normalisées ou pieds nus. On augmente progressivement l'angle d'inclinaison de cette rampe, lubrifiée avec de l'huile ou de l'eau savonneuse respectivement, jusqu'à ce que le technicien détecte des signes de glissement. Dans le cas des chaussures et de la lubrification à l'huile, les revêtements de sol sont classés en cinq catégories: de R9 à R13, sachant que plus le chiffre est élevé, plus le frottement statique est important.

Classification	Angle d'inclinaison	Adapté aux zones avec :
R9	3° - 10°	
R10	10° - 19°	Frottement statique NORMAL
R11	19° - 27°	Frottement statique AUTOMATIQUE
R12	27° - 35°	Frottement statique ÉLEVÉ
R13		FROTTEMENT STATIQUE TRÈS ÉLEVÉ

### PENDULE

La méthode du pendule de frottement, prescrite par le Code technique espagnol de la construction, est réalisée avec un pendule aux dimensions normalisées qui soutient un patin en caoutchouc. La hauteur de l'appareil est réglée de façon à ce que le patin, qui supporte une charge constante, reste en contact avec la surface pendant une distance déterminée. En mesurant la différence entre la hauteur de départ et celle atteinte par le pendule après le frottement, on attribue une valeur à la surface testée. Les sols testés avec ce système sont classés en 4 catégories, de 0 à 3; plus le chiffre est élevé, plus la résistance au glissement est grande.

Classification	Angle d'inclinaison	Adapté aux zones avec :
CTE 0	Rd ≤ 15	
CTE 1	15 > Rd ≤ 35	• Intérieurs avec pentes < 6%
CTE 2	35 Rd ≤ 45	• Intérieurs avec pentes P 6% et escaliers • Intérieurs humides (douches, toilettes, cuisines, etc.) avec pentes < 6%
CTE 3	Rd > 45	• Intérieurs humides (douches, toilettes, cuisines, etc.) avec pentes P 6% • Intérieurs humides avec graisses, huiles, etc. • Extérieurs et piscines



## 1. RUTSCHFESTE BÖDEN

Die Benutzungssicherheit der Beläge ist eine der Prioritäten bei ROCERSA. Aktuell gibt es auf internationaler Ebene einige Systeme, um die Rutschfestigkeit der Materialien zu überprüfen. ROCERSA wendet folgende Proben an:

### RAMPE

Die Methode der geneigten Rampe ist in Europa weit verbreitet und besteht aus einer in Neigung einstellbaren Plattform, über die ein qualifizierter Techniker mit einer normalisierten Sole oder barfuß läuft. Die Rampe ist jeweils mit Öl oder Seifenwasser geschmiert und wird immer stärker gegenüber der Waagerechten geneigt, bis der Techniker Anzeichen merkt, dass er gleitet. Im Falle von der Kombination Schuhe und Öl als Schmiermittel werden die Beläge in fünf Kategorien eingestuft, R9 bis R13, wobei die größere Zahl eine höhere Haftreibung angibt.

Einteilung	Neigungswinkel	Geeignet für Bereiche mit:
R9	3° - 10°	
R10	10° - 19°	NORMALER Haftreibung
R11	19° - 27°	AUTOMATISCHE Haftreibung
R12	27° - 35°	HOHE Haftreibung
R13		SEHR HOHE HAFTREIBUNG

### PENDEL

Die Methode des Pendelgeräts, die von der spanischen Bauordnung vorgeschrieben wird, besteht aus einem Pendel mit normalisierten Maßen mit Gummigleitrollen. Die Höhe der Anlage wird so eingestellt, dass die Gleitrollen, die ein konstantes Gewicht aushalten, über eine bekannte Distanz immer mit der Oberfläche im Kontakt stehen. Es wird die Differenz zwischen der anfänglichen Höhe und die des Pendels nach der Reibung gemessen und die geprüfte Oberfläche bekommt so einen Wert. Die mit diesem System überprüften Böden werden in 4 Kategorien, von 0 bis 3, eingestuft, wobei die höhere Zahl eine höhere Rutschfestigkeit angibt.

Einteilung	Neigungswinkel	Geeignet für Bereiche mit:
CTE 0	Rd ≤ 15	
CTE 1	15 > Rd ≤ 35	• Innenräume mit Neigungen < 6%
CTE 2	35 Rd ≤ 45	• Innenräume mit Neigungen P 6% und Treppen • Feuchte Innenräume (Bäder, Toiletten, Küchen, usw.) mit Neigungen < 6%
CTE 3	Rd > 45	• Feuchte Innenräume (Bäder, Toiletten, Küchen, usw.) mit Neigungen P 6% • Feuchte Innenräume mit Fetten, Ölen, usw. • Außenbereiche und Schwimmbäder



## PIE DESCALZO

En el caso del método del pie desnudo y agua jabonosa la clasificación se reduce a tres gradaciones, A, B y C en la que la primera corresponde a ángulos de rampa mayores o iguales a 12° y la clase C a ángulos mayores o iguales a 24°.

Clasificación	Ángulo de inclinación	Adecuado para zonas con:
Clase A	≤ 12°	<ul style="list-style-type: none"> <li>Zonas de paso de andar descalzo.</li> <li>Vestuarios individuales y comunes.</li> <li>Suelos de piscinas en zonas que no son de natación si la profundidad del agua &gt; de 80 cm.</li> </ul>
Clase B	≤ 18°	<ul style="list-style-type: none"> <li>Zonas de paso de andar descalzo no clasificadas en el grupo A.</li> <li>Zonas de instalación de pulverización desinfectante.</li> <li>Suelos de piscinas en las zonas que no son de natación, si la profundidad es &gt; de 80 cm.</li> <li>Secciones que no son de natación en piscinas de oleaje.</li> <li>Suelos móviles.</li> <li>Piscinas infantiles.</li> <li>Escaleras que se meten en el agua.</li> <li>Escaleras que se meten en el agua a una profundidad máxima de 1 metro con barandillas a ambos lados.</li> <li>Escaleras fuera de la zona de baño.</li> </ul>
Clase C	≤ 24°	<ul style="list-style-type: none"> <li>Escaleras que se meten en el agua no clasificadas en la clase B.</li> <li>Piscinas que se atraviesan nadando.</li> <li>Diseño de bordes de piscina inclinados.</li> </ul>

Cabe señalar que, al aumentar la rugosidad de la superficie, tiende a mejorar la fricción, pero, al mismo tiempo, aumenta la tendencia a la suciedad. Por otra parte, el uso de relieves superficiales antideslizantes puede provocar ligeras molestias al caminar sobre ellos, por lo que esta solución suele utilizarse en aquellas aplicaciones en las que resulta prioritaria la seguridad frente al resto de condicionantes (uso industrial, aceras exteriores, etc.).



## BAREFOOT

The test with barefoot operator and soapy water produces one of three grades, A, B or C, where A corresponds to a ramp angle of no less than 12° and C to no less than 24°.

Classification	Angle of inclination	Suitable for areas with:
Class A	≤ 12°	<ul style="list-style-type: none"> <li>Barefoot pedestrian areas.</li> <li>Individual and shared changing rooms.</li> <li>Pool floor in areas not for swimming where the depth of water is &gt; 80 cm.</li> </ul>
Class B	≤ 18°	<ul style="list-style-type: none"> <li>Barefoot pedestrian areas not in group A.</li> <li>Areas where disinfectant is sprayed.</li> <li>Pool floor in areas not for swimming where the depth &gt; 80 cm.</li> <li>Areas not for swimming in pools with wave machines.</li> <li>Movable floors.</li> <li>Children's pools.</li> <li>Pool ladders.</li> <li>Pool ladders in water no greater than 1 metre deep and with handrails both sides.</li> <li>Stairs away from the bathing area.</li> </ul>
Class C	≤ 24°	<ul style="list-style-type: none"> <li>Pool ladders not in class B.</li> <li>Pools that have to be swum across.</li> <li>Design of inclined pool borders.</li> </ul>

It must be pointed out that although a rougher surface will increase friction, it will also tend to get dirtier. The use of anti-slip surface textures can be uncomfortable to walk on, so this solution is usually applied to situations where safety is the major factor (industrial, exterior footpaths etc.).



## PIEDS NUS

Dans le cas de la méthode avec pieds nus et eau savonneuse, la classification se réduit à trois niveaux, A, B et C ; la première correspond aux angles de rampe supérieurs ou égaux à 12 ° et la classe C aux angles supérieurs ou égaux à 24 °.

Classification	Angle d'inclinaison	Adapté aux zones avec :
Classe A	≤ 12°	<ul style="list-style-type: none"> <li>Zones de passage pieds nus.</li> <li>Vestiaires individuels et collectifs.</li> <li>Sols des piscines dans les zones non destinées à la natation, si la profondeur de l'eau est &gt; à 80 cm.</li> </ul>
Classe B	≤ 18°	<ul style="list-style-type: none"> <li>Zones de passage pieds nus non classées dans le groupe A.</li> <li>Zones d'installation de pulvérisation de désinfectant.</li> <li>Sols des piscines dans les zones non destinées à la natation, si la profondeur est &gt; à 80 cm.</li> <li>Sections non destinées à la natation dans les piscines à vagues.</li> <li>Sols mobiles.</li> <li>Piscines pour enfants.</li> <li>Escaliers dans l'eau.</li> <li>Escaliers dans l'eau à une profondeur maximale de 1 mètre, avec des rambarde des deux côtés.</li> <li>Escaliers hors de la zone de baignade.</li> </ul>
Classe C	≤ 24°	<ul style="list-style-type: none"> <li>Escaliers dans l'eau non classés dans la catégorie B.</li> <li>Piscines à traverser à la nage.</li> <li>Conception de bords de piscines inclinés.</li> </ul>

Il faut signaler que plus la rugosité de la surface est élevée, plus le frottement a tendance à s'améliorer, mais plus la surface est salissante. D'autre part, l'utilisation de reliefs antidérapants sur la surface peut éventuellement gêner lorsque l'on marche dessus. Cette solution est par conséquent utilisée dans les cas où l'on donne la priorité à la sécurité par rapport aux autres facteurs (usage industriel, trottoirs extérieurs, etc.).



## BARFUSS

Bei der Barfußmethode und Seifenwasser gibt es drei Einstufungen, A, B und C, wobei die Erste den Neigungswinkeln größer oder gleich wie 12 ° entspricht und die Klasse C Neigungswinkel größer oder gleich wie 24 ° entspricht.

Einteilung	Neigungswinkel	Geeignet für Bereiche mit:
KLASSE A	≤ 12°	<ul style="list-style-type: none"> <li>Bereiche, in denen barfuß gelaufen wird.</li> <li>Einzel- und Gemeinschaftsumkleidekabinen.</li> <li>Schwimmbadböden in Bereichen, die nicht zum Schwimmen geeignet sind, wenn die Wassertiefe &gt; als 80 cm beträgt.</li> </ul>
KLASSE B	≤ 18°	<ul style="list-style-type: none"> <li>Bereiche, in denen barfuß gelaufen wird, die nicht in der Klasse A eingestuft sind</li> <li>Bereichen in denen Desinfektionsmittel zerstäubt wird.</li> <li>Schwimmbadböden in Bereichen, die nicht zum Schwimmen geeignet sind, wenn die Wassertiefe &gt; als 80 cm beträgt.</li> <li>Bereiche in Wellenbädern, die nicht zum Schwimmen geeignet sind.</li> <li>Bewegliche Böden.</li> <li>Kinderschwimmbekken.</li> <li>Stufen unter Wasser.</li> <li>Stufen unter Wasser mit einer maximalen Tiefe von 1 Meter mit Geländer auf beiden Seiten.</li> <li>Treppen außerhalb der Badebereichs.</li> </ul>
KLASSE C	≤ 24°	<ul style="list-style-type: none"> <li>Stufen, die in das Wasser reichen, aber nicht in Klasse B eingestuft werden.</li> <li>Schwimmbäder, die durchgeschwommen werden.</li> <li>Geeignete Schwimmbadränder.</li> </ul>

Wir weisen darauf hin, dass bei höherer Rauheit die Oberfläche besser haftet, dabei aber auch mehr Schmutz ansammelt. Andererseits kann die raue Oberfläche leicht stören, wenn man über sie läuft, diese Lösung wird normalerweise bei Anwendungen benutzt, bei denen die Sicherheit Vorrang über die restlichen Elemente hat (Gewerbe, Gehwege, usw.).



## 2. PRODUCTOS RECTIFICADOS

1. No mojar las piezas previamente a su colocación, pues pueden sufrir una ligera deformación que dificulte su colocación y su resultado final. Colocar en seco (sobre todo revestimiento).
2. Maestrear correctamente la pared antes de su colocación, pues cualquier rugosidad perjudica la colocación. El maestro deberá hacerse con mortero y dejar fraguar, al menos, 48 horas.
3. Tras el fraguado, aplicar el cemento cola con llana dentada.
4. Pese a que el material rectificado se preste a una colocación sin junta, es aconsejable dejar una mínima distancia de 0,5mm, con lo que evitaremos cualquier tipo de problema dimensional y eliminación de tensiones.
5. No golpear el material para colocarlo, pues cualquier mínimo desajuste en la pieza provocaría un efecto no deseado haciendo que las puntas no coincidieran.
6. Se deben completar las paredes.
7. No transitar sobre los pavimentos recién colocados que pudieran provocar problemas como los descritos en el punto 5.
8. Tener mucho cuidado en la manipulación de las piezas, ya que los bordes rectificadas se prestan a una fácil rotura o despuntado por su canto vivo.
9. Rejuntar con una llana de goma una vez seco el material.
10. La limpieza del rejunte deberá hacerse antes del secado de este con una esponja húmeda.

## 3. PRODUCTOS RECOMENDADOS PARA EXTERIOR

1. En colocaciones exteriores, y más aún si las condiciones meteorológicas pueden llegar a ser extremas, se recomienda únicamente la colocación de productos pertenecientes al grupo BI (gres porcelánico) siendo el más aconsejado el grupo BIa por su absorción de agua inferior al 0,5 %.
2. Previamente a la colocación del material, se debe nivelar perfectamente la superficie con pasta niveladora o mortero, formando las pendientes necesarias (2 %) que impidan el estancamiento de agua, evitando así la formación de hielo con el correspondiente riesgo de rotura del material. Se recomienda, en terrazas o zonas descubiertas, la impermeabilización y drenaje conectado a sumidero por debajo del solado. Se recomienda el uso de juntas impermeables.
3. Utilizar el cemento cola correspondiente para material con baja absorción de agua y junta impermeable que impida el paso de agua por esta, impidiendo así el filtrado y evitando, como en el punto anterior, la rotura del material como consecuencia de la formación de hielo. Asimismo, la junta mínima de colocación de 1,5 mm sigue siendo la recomendada.
4. Hay que realizar juntas de dilatación en todo el perímetro cada 6-9 m<sup>2</sup> y respetar las juntas de dilatación estructurales.
5. Debe utilizarse siempre una llana dentada en la aplicación del cemento cola y macizar mediante golpes con maza de goma. No deben quedar huecos bajo la superficie de la pieza, es decir, debe estar totalmente macizada.
6. En colocaciones de pavimentos en exterior, estos deben cumplir unos requisitos mínimos de antideslizamiento. Estos requerimientos son diferentes para cada país, habiendo vigentes distintos métodos de control del antideslizamiento como pudieran ser el Tortus, el péndulo o la rampa o plano inclinado.
7. No colocar en zonas permanentemente húmedas o susceptibles de tener presencia de humedad materiales que no cumplan con las especificaciones técnicas requeridas para este tipo de zonas.



## 2. BUTTED TILES

1. Tiles should not be wetted prior to fitting as they can deform, which makes fitting difficult and affects the final result. Install dry. (Particularly with panels).
2. Skim the wall before tiling, as any roughness can affect the installation. Skim using mortar and leave to harden for at least 48 hours.
3. Once hardened, apply cement with a toothed trowel.
4. Although butted tiles might be described as joint-less, it is always advisable to leave a 0.5mm gap to avoid problems resulting from dimensions and to relieve pressure.
5. Do not hammer the tiles into place as this could result in the tiles not being aligned correctly.
6. Walls should be tiled in their entirety.
7. Do not put pressure on freshly installed tiles as this can lead to problems as per note 5.
8. Be very careful while manipulating the tiles as their straight cut edges can break easily.
9. Grout with a rubber grouting float once set.
10. Excess grout must be cleaned off with a wet sponge before it dries.

## 3. PRODUCTS RECOMMENDED FOR OUTDOOR USE

1. For exterior installations, and more so if weather conditions can be extreme, only group BI products (porcelain) are recommended, due to their low water absorption of 0.5%.
2. Before tiling, the surface should be levelled with levelling compound or mortar. There should also be 2% run-off to avoid ice forming which can damage the materials. Adequate drainage should be installed on terraces or open areas. Impermeable joints are recommended.
3. Cement should have low water absorption and impermeable grout should be used. This is to avoid water ingress which could result in ice damage. The minimum space recommended around the tiles is 1.5 mm.
4. There should be peripheral expansion joints for every 6-9 m<sup>2</sup> and existing structural expansion joints should be respected.
5. A toothed trowel should always be used when applying cement. It must be compacted using a rubber hammer. The cement must be compacted such that no spaces remain behind tiles.
6. Exterior flooring must meet certain minimum anti-slip requirements. These requirements vary by country, employing various classification methods such as Tortus, pendulum or inclined ramp or plain.
7. For permanently wet areas or areas likely to be exposed to moisture, the correct materials that comply with all necessary technical specifications must be used.



## 2. PRODUITS RECTIFIÉS

1. Ne pas mouiller les carreaux avant de les poser car ceux-ci peuvent se déformer légèrement, ce qui complique la pose et nuit au résultat final. Poser à sec (notamment le revêtement mural).
2. Lisser correctement le mur avant la pose car toute rugosité pourrait compromettre la pose. Effectuer le lissage avec du mortier puis laisser durcir au moins 48 heures.
3. Après le durcissement, appliquer le mortier-cola à l'aide d'une taloche crantée.
4. Même si le matériau rectifié peut être posé sans joints, il est recommandé de laisser une distance minimale de 0,5 mm pour éviter tout type de problème dimensionnel et éliminer les tensions.
5. Ne pas tapoter sur le matériau pour le placer. En effet, un décalage minimal du carreau provoquerait un effet non souhaité, où les pointes ne coïncideraient pas.
6. Les murs doivent être complétés.
7. Ne pas circuler sur les revêtements de sol à peine posés susceptibles de provoquer des problèmes tels que ceux décrits au point 5.
8. Procéder avec le plus grand soin lors de la manipulation des carreaux rectifiés car ils sont fragiles ; leurs bords et arêtes vives se cassent très facilement.
9. Faire les joints avec une taloche en caoutchouc une fois que le matériau est sec.
10. Nettoyer les joints uniquement lorsqu'ils sont secs, à l'aide d'une éponge humide.

## 3. PRODUITS RECOMMANDÉS POUR L'EXTÉRIEUR

1. En extérieur, il est recommandé de poser uniquement des produits appartenant au groupe BI (grès cérame), d'autant plus si les conditions météorologiques sont extrêmes. Les produits du groupe BIa sont les plus adaptés en raison de leur absorption d'eau, inférieure à 0,5 %.
2. Avant la pose du matériau, il faut parfaitement niveler la surface avec un enduit de nivellement ou du mortier, en formant les pentes nécessaires (2 %) de façon à empêcher la stagnation de l'eau et à éviter la formation de gel, et donc le risque de rupture du matériau. Sur les terrasses et les zones sans toit, il est recommandé d'installer un système d'étanchéité et de drainage, relié à la canalisation sous le sol. Il est recommandé d'utiliser des joints imperméables.
3. Utiliser un mortier-cola adapté aux matériaux à faible absorption d'eau et aux joints imperméables pour éviter le passage de l'eau et les infiltrations qui pourraient entraîner, comme dans le point précédent, la rupture du matériau due à la formation de gel. Il est recommandé de respecter le même joint minimum de pose de 1,5 mm.
4. Il faut réaliser des joints de dilatation tout au long du périmètre tous les 6-9 m<sup>2</sup>, tout en respectant les joints de dilatation structurels.
5. Pour l'application du mortier-cola, toujours utiliser une taloche crantée et tasser en tapotant à l'aide d'un maillet en caoutchouc. Ne laisser aucun creux sous la surface du carrelage, qui doit être entièrement enfoncé.
6. Pour la pose en extérieur, les revêtements de sol doivent respecter des exigences minimales antidérapantes. Ces exigences sont différentes en fonction des pays ; il existe en effet plusieurs méthodes d'évaluation de la glissance, tels que Tortus, le pendule, ou encore la rampe ou plan incliné.
7. Dans les zones toujours humides ou susceptibles d'être humides, ne jamais poser des matériaux non conformes aux spécifications techniques exigées pour ce type de zone.



## 2. MODIFIZIERTE PRODUKTE

1. Die Stücke vor der Verlegung nicht nass machen, da sie sich leicht verformen können, was die Verlegung erschwert und das Ergebnis beeinträchtigen kann. Trocken verlegen (besonders Verkleidungen).
2. Die Wand vor der Verlegung korrekt glätten, jede Rauheit beeinträchtigt die Verlegung. Die Glättung muss mit Mörtel vorgenommen werden und er mindestens 48 Stunden aushärten.
3. Nach der Aushärtung wird der Zementkleber mit einer gezahnten Kelle aufgetragen.
4. Obwohl das modifizierte Material ohne Fugen verlegt wird, empfehlen wir, einen Mindestabstand von 0,5 mm zu lassen, wodurch Ausdehnungsprobleme und Spannungen vermieden werden.
5. Klopfen Sie bei der Verlegung nicht auf das Material, da auch schon kleinste Verschiebungen einen nicht erwünschten Effekt mit sich bringen könnten und die Ecken nicht übereinstimmen.
6. Wände müssen vollständig verlegt werden.
7. Frisch verlegte Beläge nicht begehen, da die in Punkt 5 erläuterten Probleme auftreten könnten.
8. Die Stücke mit äußerster Sorgfalt handhaben, da die geschliffenen Ränder leicht brechen oder abstumpfen.
9. Sobald das Material trocken ist, mit einer Gummikelle verfugen.
10. Die Reinigung der Verfugung muss mit einem feuchten Schwamm vorgenommen werden, bevor das Material trocken ist.

## 3. FÜR AUSSEN EMPFOHLENE PRODUKTE

1. Bei Verlegungen in Außenbereichen, besonders bei extremen Klimabedingungen, empfehlen wir nur die Verlegung von Produkten der Gruppe BI (Feinsteinzeug), wobei die Gruppe BIa wegen ihrer Wasseraufnahme von weniger als 0,5 % empfohlen wird.
2. Vor der Verlegung des Materials muss die Oberfläche mit Nivellierungspaste oder Mörtel komplett plan gemacht werden, wobei die notwendigen Neigungen (2 %) geformt werden, die verhindern, dass sich Eis ansammelt, was verursachen könnte, dass das Material brechen könnte. Auf Terrassen und freie Bereiche empfiehlt sich eine Imprägnierung und Drainage mit Ablauf unter der Verlegung. Außerdem empfehlen wir wasserundurchlässige Fugen.
3. Es muss der für das Material mit geringer Wasseraufnahme geeignete Zement und eine wasserundurchlässige Fuge benutzt werden, damit nichts durchsickern kann, um zu verhindern, dass wie in dem vorigen Punkt, das Material durch Eisbildung bricht. Weiterhin wird eine Verlegung mit einem Abstand von 1,5 mm empfohlen.
4. Es müssen Dehnfugen auf der ganzen Fläche alle 6-9 m<sup>2</sup> gesetzt werden, wobei strukturelle Dehnfugen berücksichtigt werden müssen.
5. Es muss immer eine gezahnte Kelle bei dem Umgang mit Zementkleber benutzt werden und einen Gummihammer, um die Stücke zurechtzuklopfen. Es dürfen keine Lücken unter der Oberfläche zurückbleiben, die Stücke müssen alle fest sitzen.
6. Bei der Verlegung in Außenbereichen müssen diese die Mindestanforderungen in Sachen Rutschfestigkeit erfüllen. Diese Anforderungen sind in jedem Land anders, wobei es verschiedene Kontrollmethoden zur Rutschfestigkeit gibt, wie etwa Tortus, das Pendel, Rampe oder die geeignete Fläche.
7. Nicht in permanent feuchten Bereichen oder die Feuchtigkeit vorweisen können verlegen und die nicht die erforderlichen technischen Spezifizierungen für diese Bereiche erfüllen.



#### 4. CONDICIONES GENERALES DE VENTA

1. La mercancía viaja por cuenta y riesgo del comprador.
2. Los colores de catálogo e ilustraciones son puramente orientativas de la gama.
3. Nuestros materiales están sujetos a tonalidad y a las tolerancias que establece la norma ISO 13.006 / EN 14411.
4. No se responde de las reclamaciones sobre material ya colocado.
5. Nuestras garantías obedecen sólo a la reposición de material sin colocar.
6. Nos reservamos la facultad de cambiar nuestros precios con un preaviso de 30 días.
7. Los pagos se efectuarán directamente a Roig Ceramica S.A. (Rocersa), excepto en los casos en que deleguemos por escrito a personas autorizadas.
8. El retraso en 30 días a la fecha de cobro será sancionado como insolvencia. En tal caso será de nuestra facultad suspender los pedidos pendientes y por ello pedir judicialmente el pago de lo debido. Todos los gastos ocasionados por la demora, serán por cuenta del deudor.
9. Sobre la mercancía que ocupará cada factura, Roig Ceramica S.A. (Rocersa), se reserva el derecho de dominio hasta no haya sido cobrado el importe de la misma incluso sobre las transacciones a terceros.
10. En caso de litigio ambas partes se someterán a los Juzgados y Tribunales de Castellón (España).

ENTREGA: Todas las mercancías se consideran como recibidas y aceptadas en fábrica. Se expedirán por orden, cuenta y riesgo del comprador. Las faltas de peso o rotura deben reclamarse a las Compañías de Transportes, únicas responsables.

#### 5. INFORMACIÓN DE UTILIDAD

Todas las informaciones, datos y características técnicas que aparecen en este catálogo fueron acumulados hasta la edición de este (enero de 2021). El fabricante se reserva el derecho de introducir las modificaciones y cambios que considere necesarios en beneficio del producto y del cliente.

En caso de duda o confrontación de informaciones, estas deben ser confirmadas a través de la empresa o el agente que la represente, ya que los datos que aparecen en este catálogo no se considerarán vinculantes.

El contenido de este catálogo está protegido en su totalidad por copyright. Queda prohibida la reproducción total o parcial de las imágenes, textos, ilustraciones y conceptos gráficos sin la autorización expresa de Roig Cerámica, S.A.

Debido a los procesos técnicos de reproducción, los colores son aproximados, no exactos.



#### 4. GENERAL SALE TERMS

1. The merchandise is sent at buyer's risk and account.
2. The colour and images of the series shown in the catalogue are purely orientative.
3. Our products are subject to shade and caliber variation, as well as tolerances as per the european norm in force ISO 13.006 / EN 14411.
4. We will not be held responsible for any items once these have been laid out.
5. Our guarantee applies only for tiles that are not installed.
6. We reserve the rights to change prices with a previous 30 day notice.
7. Payment are strictly made to Roig Ceramica S.A. (Rocersa), except in those cases when we delegate in writing to be effected to an authorized person.
8. Any overdue payments for 30 days will be considered as insolvency, and in such a situation we reserve the rights to put any pending orders on hold, and take legal action if considered convenient, and all expenses incurred will be at debtor's account.
9. The goods listed on every invoice remain property of Roig Ceramica S.A. (Rocersa), until these have been cleared in full, this applies to any transactions made with agents or third parties too.
10. In case of litigation this will be submitted through the court of justice in Castellón.

DELIVERY: All the goods will be considered as accepted & received by the customer once these leave the factory, and these will be sent by order of the customer and at his own account and risk any breakage or missing items are to be claimed to the transport company.

Carriers are responsible for breakage and / or underweight / overweight.

#### 5. USEFUL INFORMATION

All information, data and technical characteristics appearing in this catalogue, were gathered prior to the publication of same (January 2021). The manufacturer reserves the right to make changes considered necessary for the benefit of the product and of the client.

In case of doubt or contradictions, these must be taken up with the company or its agent as data contained herein shall not be binding.

The entire content of this catalogue is protected by copyright. Reproduction in whole or in part of any images, text, illustrations or graphical concepts is prohibited without express authorisation of Roig Cerámica, S.A.

Owing to printing processes, colours shown are approximate.



#### 4. CONDITIONS GENERALES DE VENTE

1. La marchandise voyage aux risques et périls de l'acheteur.
2. Les coloris de nos catalogues et illustrations sont uniquement une orientation de notre gamme.
3. Nos produits s'adaptent aux tolérances données par les normes ISO 13.006 / EN 14411 établies.
4. Nous ne pouvons accepter de réclamation de nos produits après sa pose, s'il existe un problème de qualité apparent.
5. Nos garanties ne sont valables, en cas de défaut, que pour les produits non posés.
6. Nous nous réservons le droit de modifier nos prix et tarifs avec un préavis de 30 jours.
7. Les paiements s'effectueront directement à Roig Ceramica S.A. (Rocersa), sauf quand la Société donne l'autorisation par écrit à une autre personne.
8. Un retard de règlement supérieur à 30 jours à la date accordée sera considéré comme manque de solvabilité de la part du client, sauf preuve du contraire. Les commandes en cours seraient paralysées ou annulées. Le règlement pouvant être réclamé par VOIE JUDICIAIRE, tenants comptes des frais d'agios et autres.
9. Roig Ceramica S.A. (Rocersa), se réserve le droit de propriété, selon la LOI NUM 80.325 du 2 mai 1980, jusqu'à complet paiement de pouvoir faire des poursuites aux tierces personnes.
10. En cas de litige, seul le Tribunal de Castellón (Espagne) est compétent.

La marchandise est vendue au DEPART USINE d'où elle est chargée dans de bonnes conditions, celle-ci ne pourra faire l'objet de réclamations dans le cas de casse ou autres causes similaires qu'au TRANSPORTEUR correspondant.

#### 5. INFORMATIONS UTILES

L'ensemble des informations, des données et des caractéristiques techniques que contient ce catalogue ont été accumulées jusqu'à sa publication (janvier 2021). Le fabricant se réserve le droit de réaliser les modifications et les changements qu'il juge nécessaires pour améliorer le produit et la satisfaction du client.

En cas de doute ou de confrontations d'informations, celles-ci sont à confirmer auprès de l'entreprise ou de l'agent qui la représente, car celles qui figurent dans ce catalogue ne sont pas considérées comme contraignantes.

Le contenu de ce catalogue est protégé dans sa totalité par copyright. Toute reproduction des images, textes, illustrations et concepts graphiques, même partielle, est interdite dans l'autorisation expresse de Roig Cerámica, S.A.

En raison des procédés techniques de reproduction, les couleurs ne sont pas précises mais approximatives.



#### 4. VERKAUFSBEDINGUNGEN

1. Die Ware wird auf eigene Gefahr des Käufers verfrachtet.
2. Die Farben in unsere Prospekten und Kataloge dienen nur zur Orientierung.
3. Unser Material entspricht in Brand und Toleranz der aktuellen Norm (ISO 13.006 / EN 14411)
4. Reklamationen nach Verlegen des Materials werden nicht akzeptiert.
5. Unseren Garantien und somit Ersatzlieferungen sind nur gültig, wenn das Material noch nicht verlegt wurde.
6. Wir behalten uns das Recht vor, unsere Preise mit einem Voravis von 30 Tagen zu ändern.
7. Die Rechnungen werden direkt an Roig Ceramica S.A. (Rocersa), bezahlt, außer wenn wir schriftlich eine bestimmte Person damit beauftragen.
8. Eine Verspätung der Zahlung in mehr als 30 Tagen, wird als Zahlungsunfähigkeit von Seitens des Kunden betrachtet. In diesem Fall werden laufenden Bestellungen storniert und der Gesamtbetrag gesetzlich eingetrieben. Jeglich verursachte Kosten sind vom Schuldner zu tragen.
9. Bis zur vollständigen Bezahlung der Rechnung reserviert sich Roig Ceramica S.A. (Rocersa), das vollständige Eigentumsrecht vor. Dies beinhaltet auch Verhandlungen mit Dritten Personen.
10. Im Streitfall ist für beide Parteien der Gerichtshof in Castellón (Spanien) zuständig.

ANLIEFERUNG: Die Ware wird im Werk übernommen und auf Risiko des Käufers verfrachtet. Fehlende Gewichte oder Schäden des Materials müssen direkt an den Spediteur reklamiert werden, da diese die einzigen Verantwortlichen sind.

#### 5. WICHTIGE INFORMATION

Alle Informationen, Daten und technische Eigenschaften in diesem Katalog wurden während der Auflage (Januar 2021) gesammelt. Der Hersteller hält sich das Recht vor, die notwendigen Veränderungen und Modifizierungen zu Gunsten des Produkts und des Kunden vorzunehmen.

Bei Fragen oder gegensätzlichen Informationen müssen diese von dem Unternehmen oder dem Vertreter bestätigt werden, da die Daten in dem Katalog ohne Gewähr sind.

Der Inhalt des Katalogs ist vollständig durch Copyright geschützt. Eine vollständige oder partielle Wiedergabe der Bilder, Texte, Abbildungen und graphischen Konzepten ist ohne die ausdrückliche Genehmigung von Roig Cerámica, S.A. untersagt.

Durch die technischen Wiedergabeprozesse sind die Farben ungefähr, nicht exakt.



# Comprometidos con el medio ambiente

*Committed to the environment*

El medioambiente y los efectos negativos de la emergencia climática, preocupan y ocupan cada vez más y nuestra empresa no es ajena a esta realidad, que tanto preocupa a la sociedad actual.

Hemos realizado estudios, para la optimización de formas y usos de la energía, en la investigación en energías alternativas o en la optimización de procesos y productos con la finalidad de lograr un crecimiento y desarrollo industrial que no impacte en el entorno, o que reduzca estos impactos al mínimo.

Realizando estudios para optimización de los procesos industriales, para la reducción del consumo de energía, optimizando las variables del proceso, aprovechamiento de calores residuales, búsqueda de las mejores tecnologías de recuperación de calor, análisis termográfico de las instalaciones, reducción de emisiones de CO2.

Reciclado de residuos sólidos urbanos e industriales, mediante tratamiento y acondicionamiento para su utilización como materias primas en productos cerámicos. Diseño de productos y procesos capaces de reciclar elevados porcentajes de residuos.

Rocersa elabora planes de ahorro y mejora de la gestión de las aguas residuales generadas en el proceso productivo diseñando estrategias para mejorar la sostenibilidad ambiental de productos y/o proceso, realizando análisis medioambientales de la situación de la empresa respecto a la contaminación atmosférica y elaborando planes de mejoras enfocadas a la reducción de las emisiones contaminantes.

En Rocersa estamos comprometidos, en la lucha contra el cambio climático por ello no cesará en esta lucha, para lograr procesos, en equilibrio con la naturaleza

*More and more the society is increasingly concern about the environment and the negative effects of the climatic emergency and our company does not distance itself from things that matter to our society.*

*We have carried out studies for the optimization of forms and uses of energy, in research into alternative energies or process optimization and products with a view to achieving industrial development that does not impact negatively in the environment or to minimise these impacts.*

*Conducting studies for process optimization for the reduction of the consumption of energy, optimizing process variables, harnessing of residual heat technologies, search for improved heat technologies, thermographic analysis of the installations, reductions of CO2 emissions.*

*Recycling of solid urban and industrial waste, by treating and conditioning for their use as raw materials in ceramic tiles.*

*We design products and processes capable of recycle high percentages of waste.*

*Rocersa draws up savings and improvement plans for the management of waste water generated in the productive process by designing strategies to improve the environmental sustainability of products and processes, therefore we carry out environmental analysis of the situation of the Enterprise with regard to pollution and developing focused improvement plans reduction of pollutant emissions.*

*In Rocersa we are committed to the fight against climate change and will therefore not stop our engage to achieve processes in balance with nature.*

- Este catálogo puede incluir especificaciones inexactas o con errores, los que serán corregidos por ROIG CERÁMICA, S.A. tan pronto como sea posible. Los datos contenidos en este catálogo pueden ser incorrectos. ROIG CERÁMICA, S.A. no se hace responsable en ningún caso de los daños y perjuicios de cualquier naturaleza que pudieran ocasionarse por el uso de este catálogo, a título enunciativo: errores u omisiones en los contenidos. Los productos que se incluyen en este catálogo puede que no estén disponibles para comercializarse en determinadas zonas o países y puede que algunos de los productos no puedan estar disponibles de forma inmediata. ROIG CERÁMICA S.A. se reserva el derecho de añadir sin previo aviso y en cualquier momento o por cualquier motivo, todas las modificaciones que considere oportunas. Los colores, datos y descripciones contenidas en este catálogo son orientativas. El aspecto del material podrá variar ligeramente del mostrado en las fotografías.

- This catalogue may include inexact specifications or specifications with errors, which shall be corrected by ROIG CERÁMICA, S.A. as soon as possible. The data contained in this catalogue may be incorrect. ROIG CERÁMICA, S.A. does not accept responsibility in any circumstances for the damages of any nature that may be caused by the use of this catalogue, by way of example: errors or omissions in the contents. The products that are included in this catalogue may not be available to be marketed in certain areas or countries and some of the products may not be available immediately. ROIG CERÁMICA, S.A. reserves the right to add, without prior notice and at any time or for any reason, all the modifications that it considers appropriate. The colours, details and descriptions contained in this catalogue are indicative. The appearance of the material may vary slightly from that shown in the photographs.

- Ce catalogue peut contenir certaines spécifications inexactes ou comportant des erreurs, qui seront corrigées par ROIG CERÁMICA, S.A. dans les plus brefs délais. Il se peut que les données contenues dans ce catalogue ne soient pas correctes. ROIG CERÁMICA, S.A. ne saurait en aucun cas être tenue responsable des dommages et préjudices de quelque nature que ce soit qui pourraient être causés suite à l'utilisation de ce catalogue, à titre énonciatif : erreurs ou omissions dans les contenus. Il est possible que les produits qui figurent dans ce catalogue ne soient pas disponibles pour la commercialisation dans certaines régions ou pays et il se peut que certains des produits ne soient pas disponibles immédiatement. ROIG CERÁMICA S.A. se réserve le droit d'ajouter sans préavis et à tout moment ou pour quelques raisons que ce soit, toutes les modifications qu'elle estimera opportunes. Les couleurs, les données et les descriptions contenues dans ce catalogue sont données à titre indicatif. L'aspect du matériel pourra être légèrement différent de celui qui est montré sur les photos.

- Dieser Katalog kann ungenaue oder fehlerhafte Spezifikationen enthalten, die von ROIG CERÁMICA, S.A. sobald wie möglich korrigiert werden. Die in diesem Katalog enthaltenen Daten sind möglicherweise nicht ganz richtig. ROIG CERÁMICA, S.A. haftet in keinem Fall für mögliche Schäden jeglicher Art, die sich durch die Nutzung dieses Katalogs ergeben könnten, einschließlich Fehler oder Auslassungen in den Inhalten. Die in diesem Katalog aufgeführten Produkte sind für den Vertrieb in bestimmte Regionen oder Länder eventuell nicht verfügbar; einige können möglicherweise nicht sofort ausgeliefert werden. ROIG CERÁMICA S.A. behält sich das Recht vor, jederzeit ohne Vorankündigung und aus jeglichem Grund Änderungen nach eigenem Ermessen durchzuführen. Bei den Farben, Angaben und Beschreibungen in diesem Katalog handelt es sich um Richtwerte. Das tatsächliche Aussehen des Materials kann deshalb von den Fotos leicht abweichen.



**rocersa**<sup>®</sup>

**Oficinas centrales**

Camino Viejo de Onda, s/n.

12540 Vila-real, Castellón (España)

T\_(+34) 964 506 242 - Fx\_(+34) 964 531 428

**Fábrica**

Camino Foyes Ferraes, 15.

12110 L'alcora, Castellón (España)

T\_(+34) 964 386 060 - Fx\_(+34) 964 386 397

[rocersa@rocersa.es](mailto:rocersa@rocersa.es) - [rocersa.com](http://rocersa.com)

